

# UNE BÊTE DE SOMME SUR ROUES

Difficile d'imaginer un véhicule plus emblématique de l'Amérique que le pick-up. Né il y a plus d'un siècle, le robuste pick-up américain original s'est transformé, par de constantes innovations, en un luxueux transporteur à la pointe de la modernité.



## MODÈLE TT



**1917-1927**

Si le modèle T a mis l'Amérique derrière un volant, le modèle TT l'a mise au travail. Avec sa charge utile de 0,9 tonne et les nombreuses possibilités qu'offre sa benne, ce véhicule performant et polyvalent est devenu un usager répandu des routes des États-Unis.

## F-SERIES



**1948-1952**

La première génération du F-series a marqué le lancement de la nouvelle stratégie d'élargissement de la gamme par Ford, avec un choix de pick-ups de différentes tailles et aux fonctions de transport variées.

**1917**

**1935**

**1948**

**1961**

## PICK-UP FORD MODÈLE 50



**1935-1941**

Plus de quatre millions de ces solides pick-up, alimentés par le légendaire moteur V-8 de Ford à soupapes latérales, ont été produits entre 1935 et 1941.

## QUATRIÈME GÉNÉRATION



**1961-1966**

Avec le slogan « La conduite d'une voiture, la performance d'un camion », ce pick-up a été le premier à cibler également les utilisateurs non commerciaux.

## SIXIÈME GÉNÉRATION



Mettant toujours l'accent sur le confort, ce dernier F-150 a inauguré un système de chauffage et de climatisation nettement plus performant. Afin de renforcer la sécurité, le réservoir de carburant a également été placé hors de la cabine.

## DIXIÈME GÉNÉRATION



Pensé pour une utilisation personnelle, le F-150 a été entièrement remanié, avec un nouveau moteur V6 et quatre portes pleine hauteur. Ses lignes modernes et ses nouvelles technologies ont valu au F-150 de remporter un vif succès auprès des acheteurs et le prix du camion de l'année.

**1973**

**1987**

**1997**

**2009**

## HUITIÈME GÉNÉRATION



Cette génération a fait l'objet de nombreuses modifications au niveau des panneaux de carrosserie et de l'habitacle. Elle a surtout vu l'introduction des moteurs à injection électronique qui ont rendu le F-150 plus puissant et plus efficace.

## DOUZIÈME GÉNÉRATION



Avec ses roues chromées de 50,8 cm, sa sellerie en cuir ainsi que ses sièges chauffants et ventilés, cette génération du F-150 offrait à ses clients un luxe d'un tout autre niveau.



## LE FORD F-150 RAPTOR DE 3<sup>E</sup> GÉNÉRATION

Depuis le premier modèle TT jusqu'à la dernière version du F-150 Raptor lancée en 2021, le chemin a été long, mais l'esprit reste sensiblement le même. Créé par Ford Performance, le Raptor est un pick-up très performant homologué pour la route et l'un des

véhicules tout-terrain les plus efficaces. Il associe le moteur le plus puissant de la gamme F-150 à une suspension robuste adaptée à la conduite hors route.



“

**LA QUALITÉ CONSISTE À BIEN FAIRE LES CHOSES  
QUAND PERSONNE NE REGARDE ”**

Henry Ford





# LES MOTS DE L'ÉQUIPE DE DESIGN

L'équipe de design LEGO® Technic a travaillé en étroite collaboration avec les designers et les ingénieurs de Ford afin de s'assurer que la version Technic du F-150 Raptor se rapproche le plus possible du véritable véhicule. La plus grande difficulté rencontrée par l'équipe a été de créer une configuration d'essieu arrière et une structure de suspension permettant un parfait alignement des roues arrière et des passages de roues.

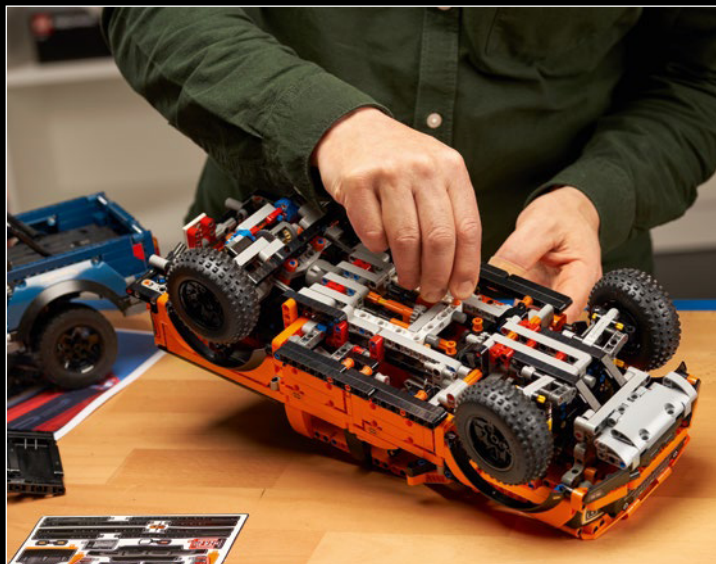

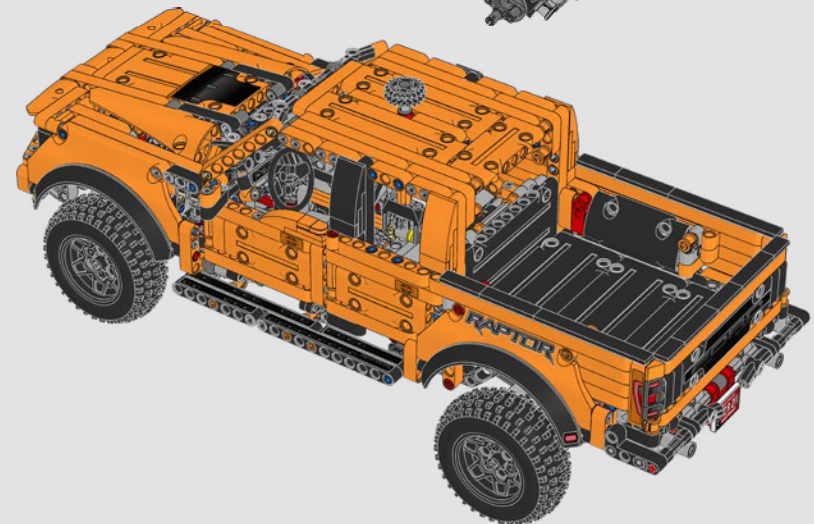
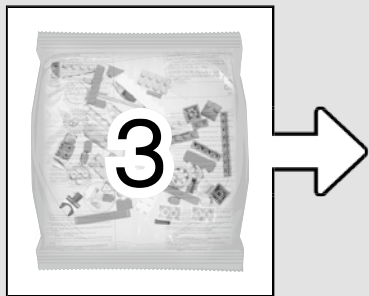
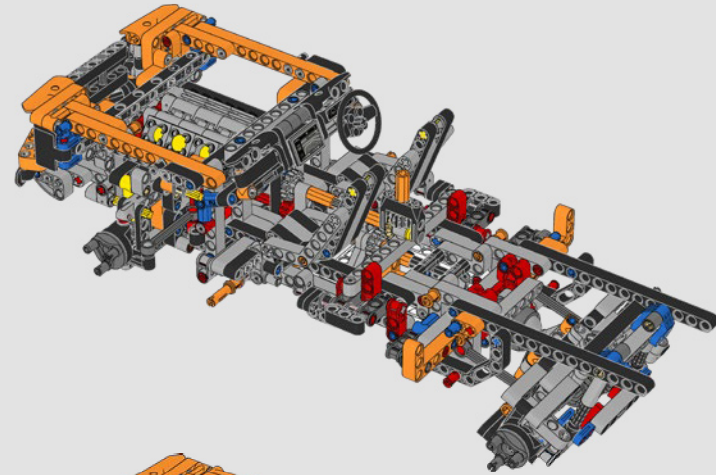
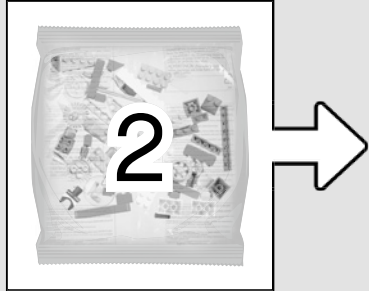
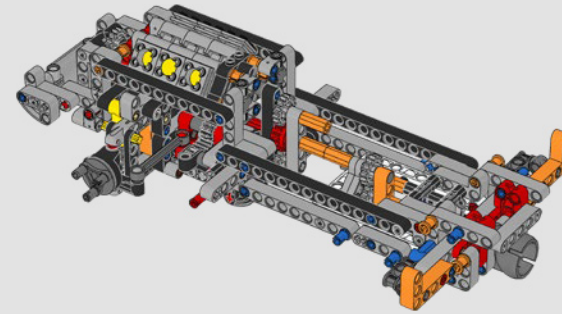
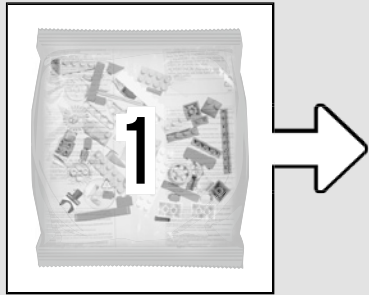

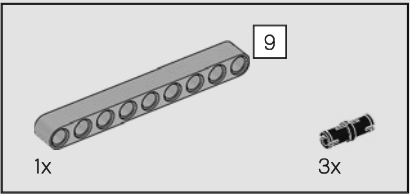
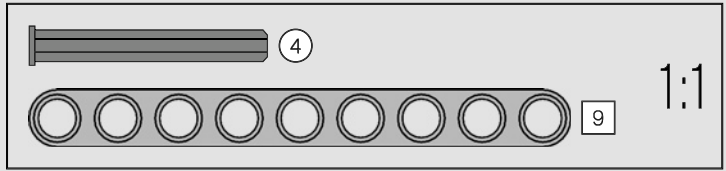
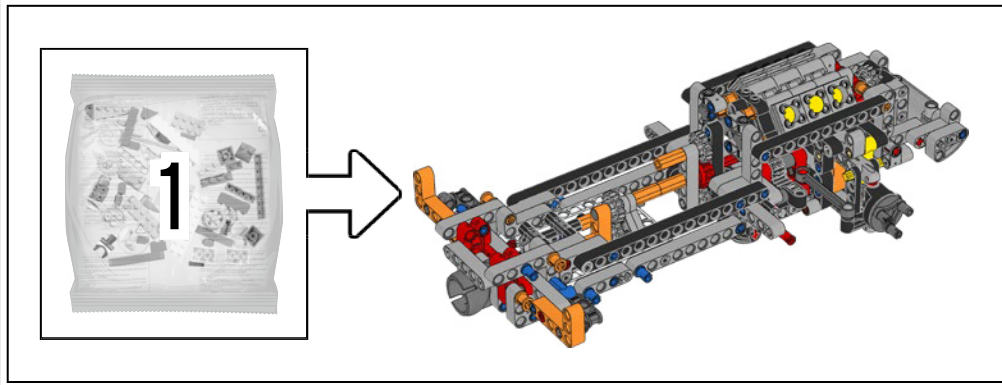

1

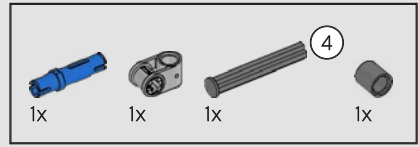
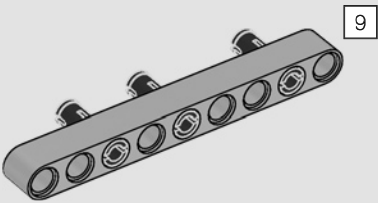

2

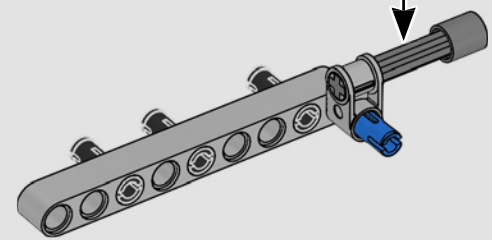
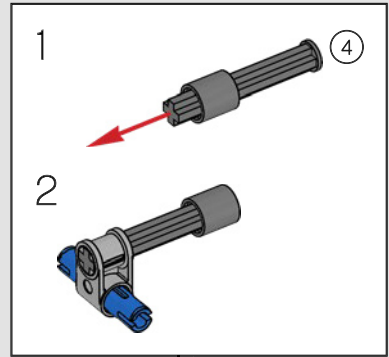

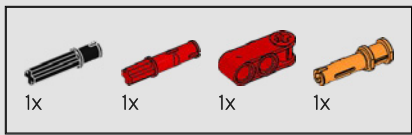

3

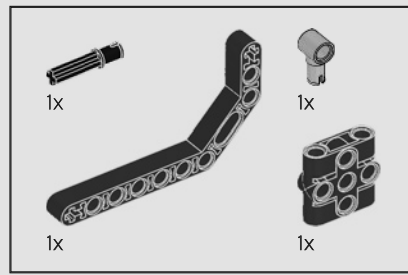
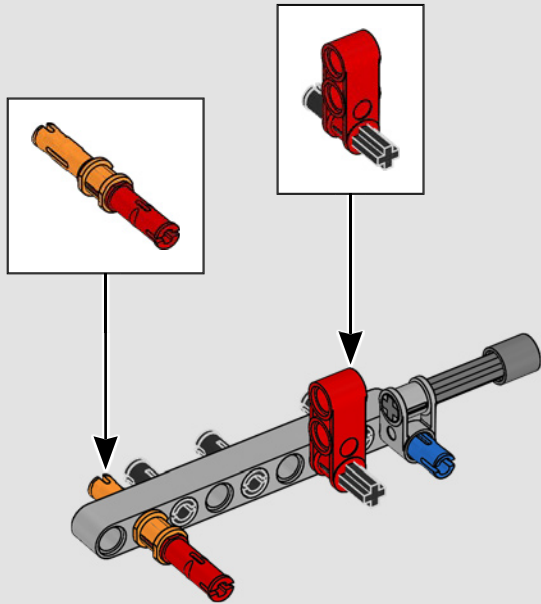

4

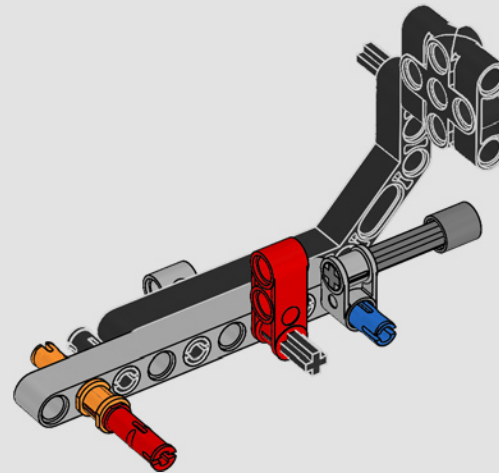
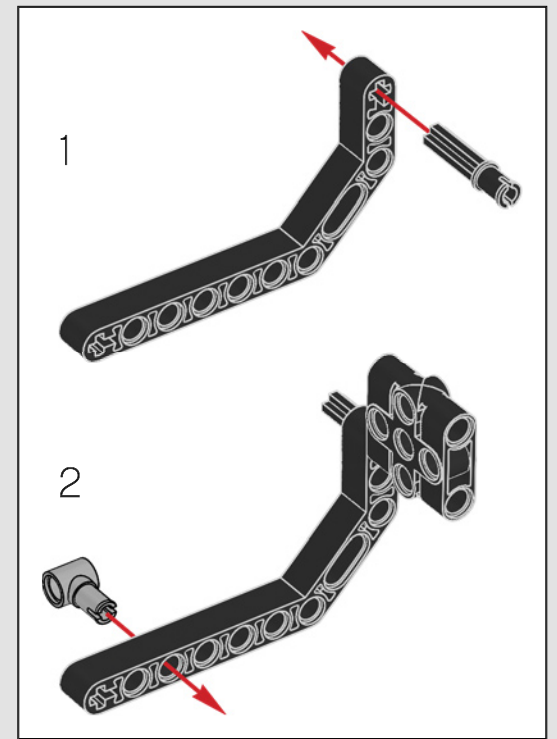

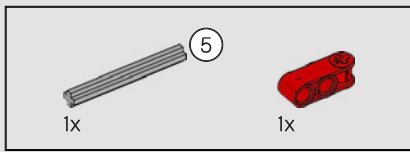

5

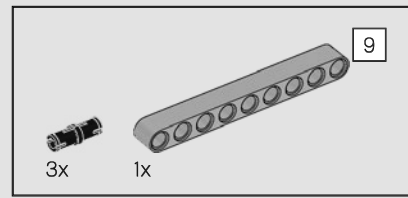
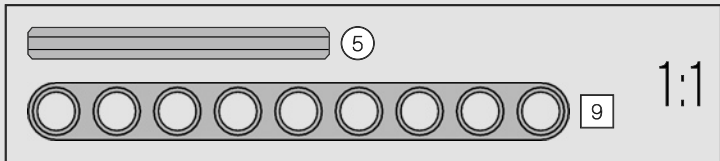
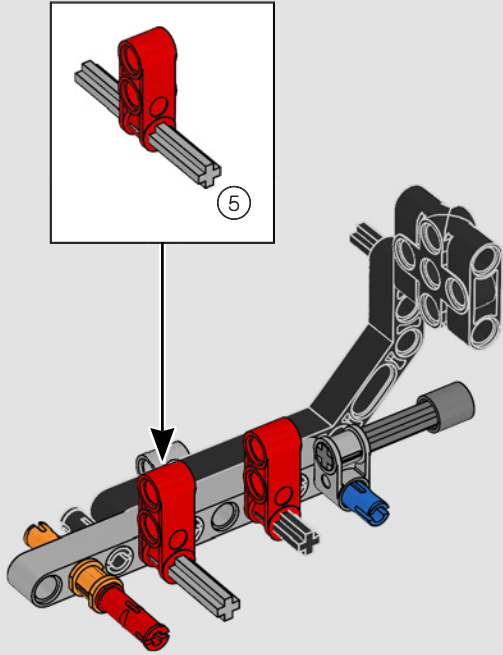

6

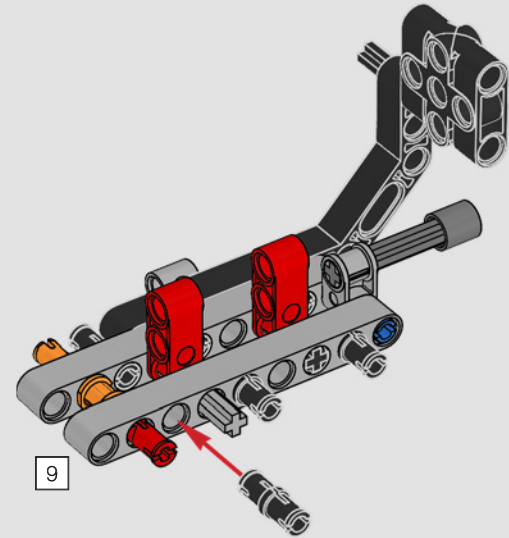

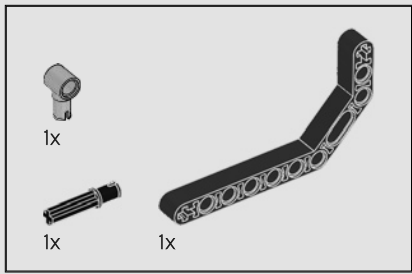

7

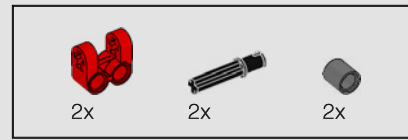
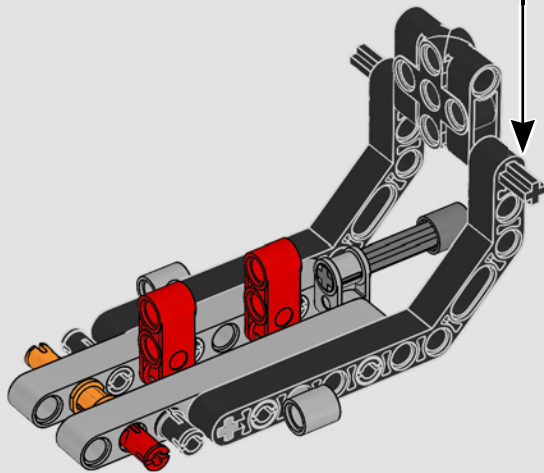
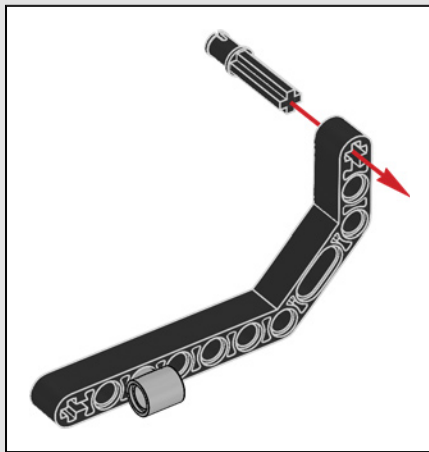

8

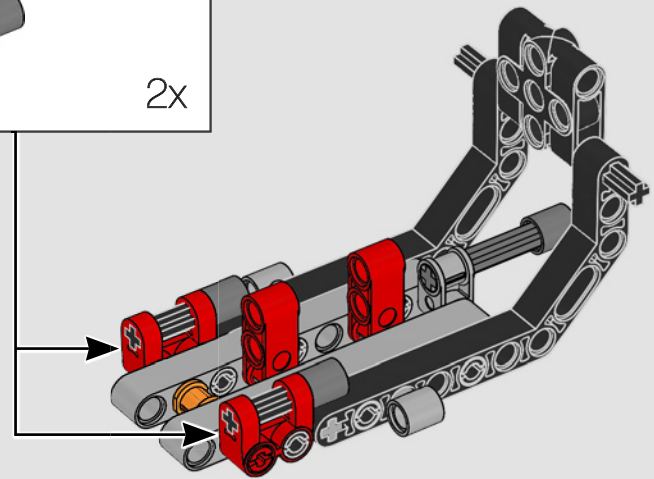
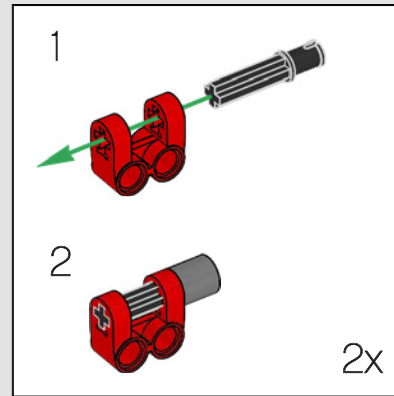



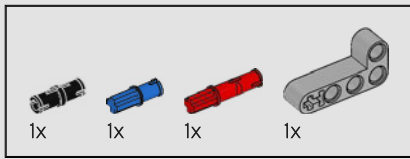

9

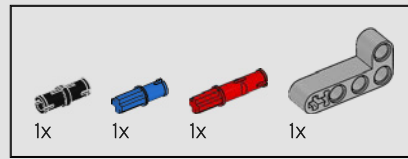
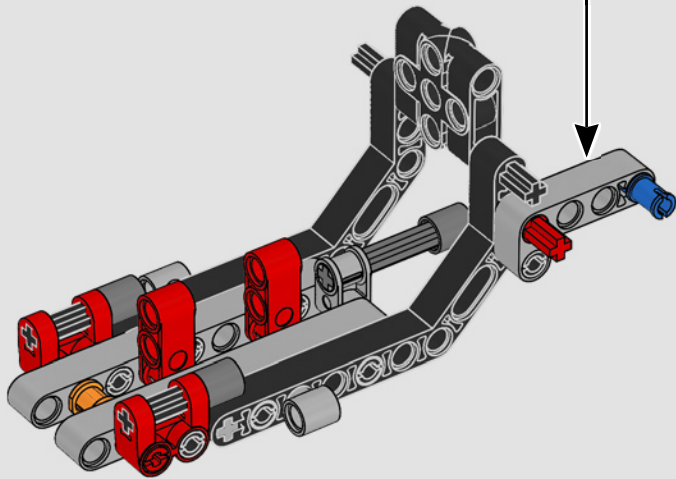
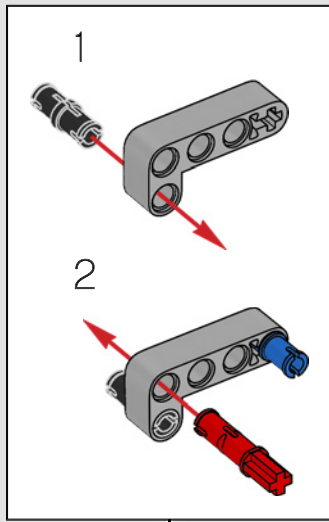

10

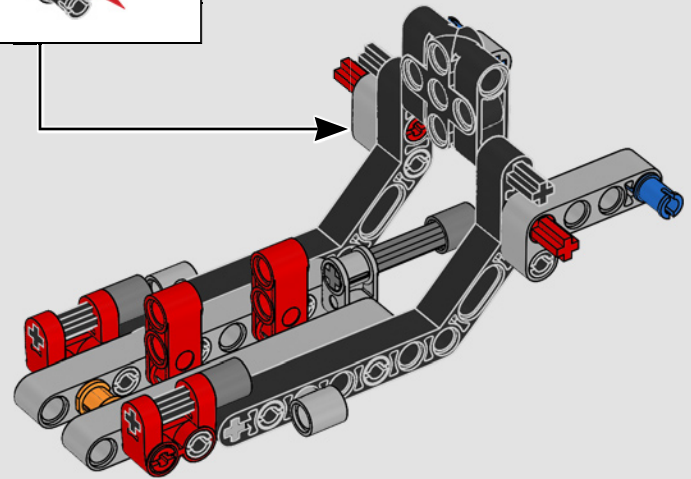
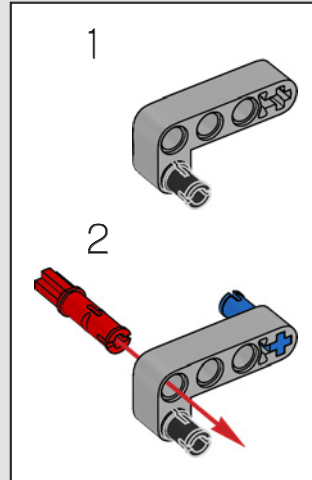



11

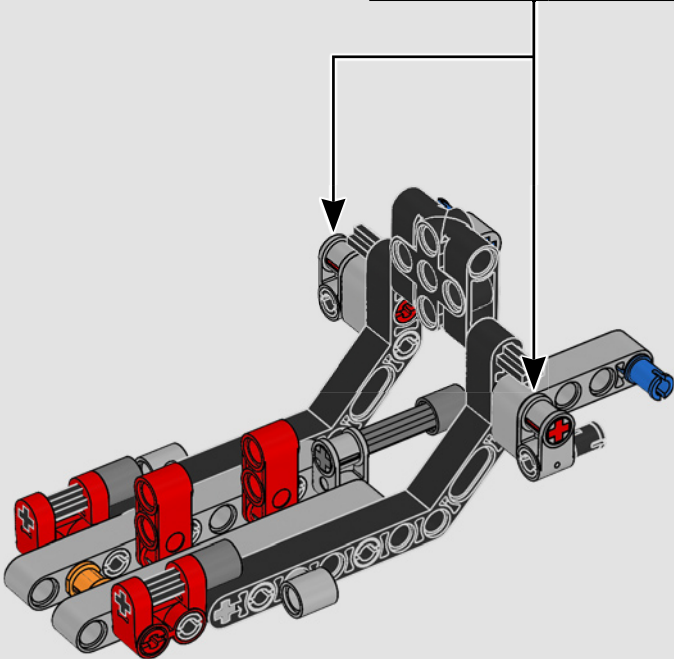
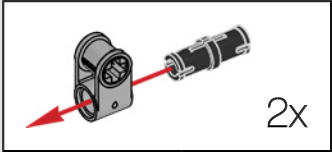

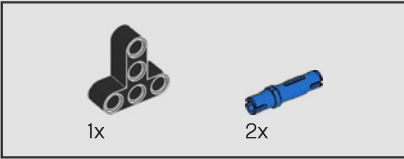
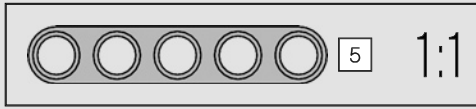
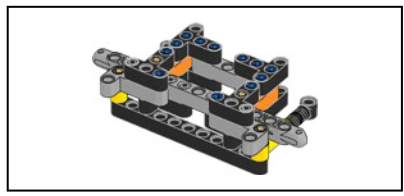

12

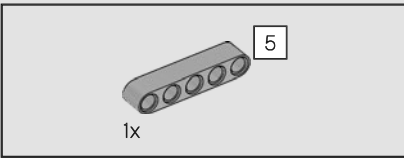
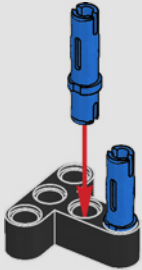

13

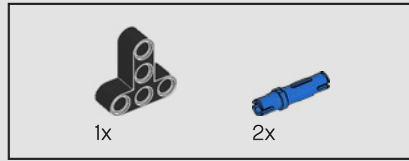
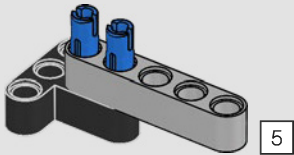

14

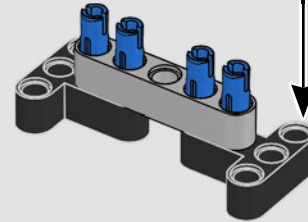
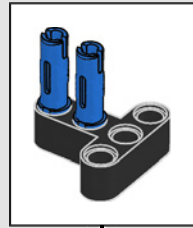

15

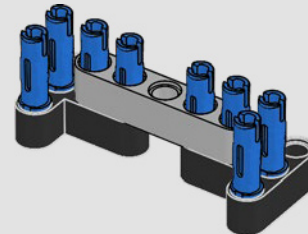

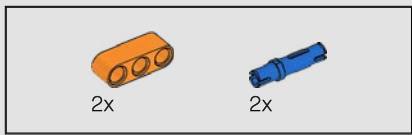

16

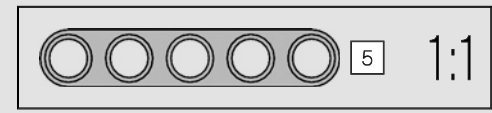
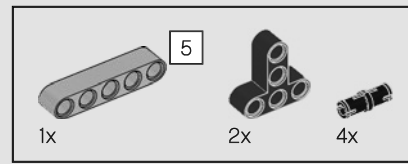
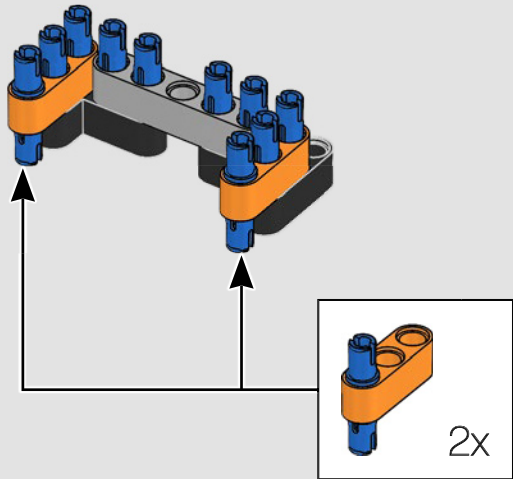

17

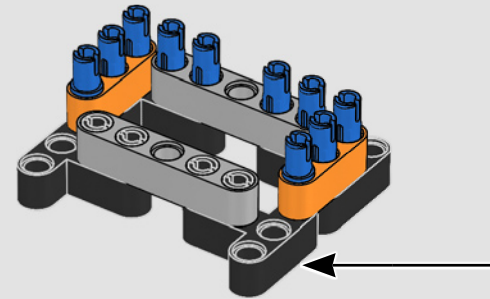
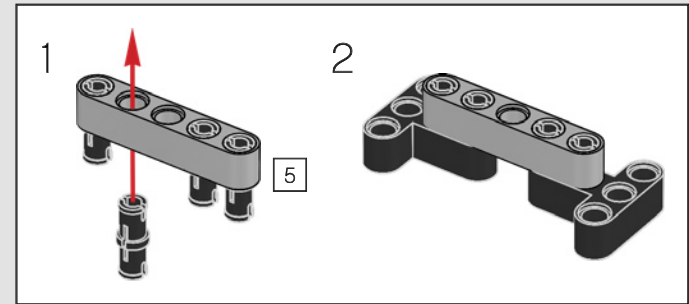

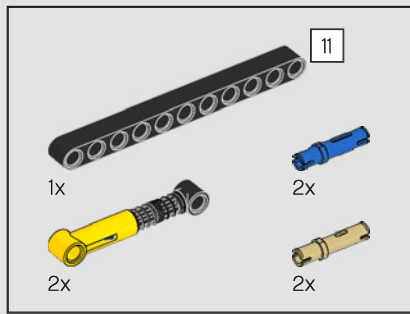

18

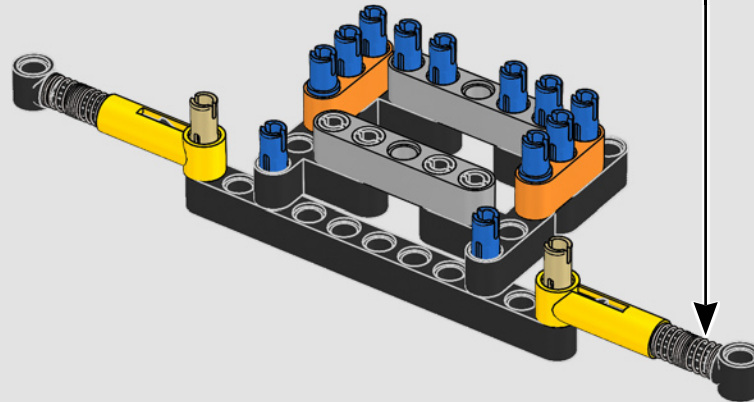
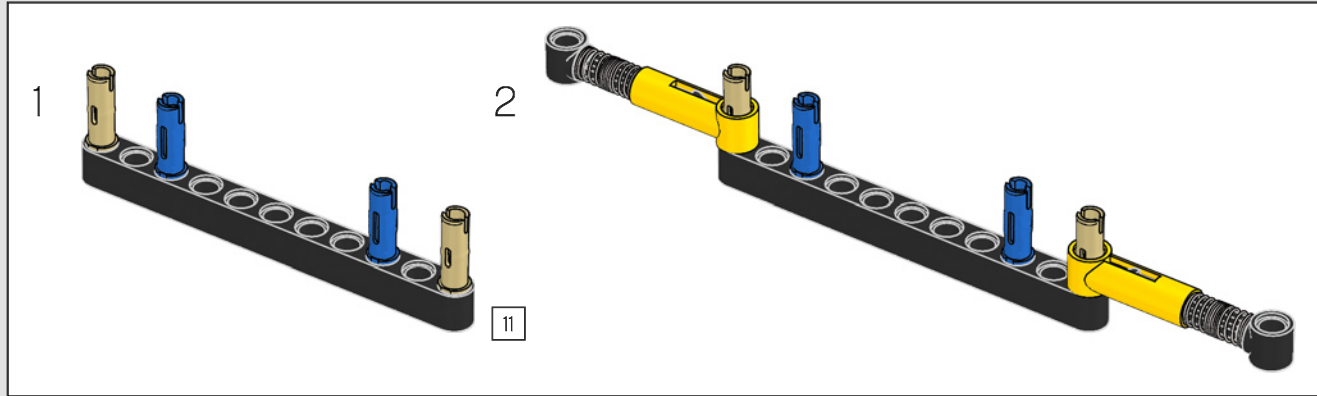

*Le F-150 Raptor est équipé d'amortisseurs monotube FOX™ Live Valve qui s'adaptent automatiquement au terrain.*



19

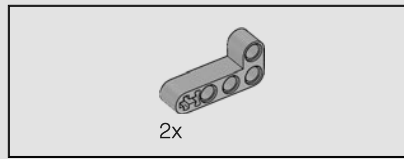
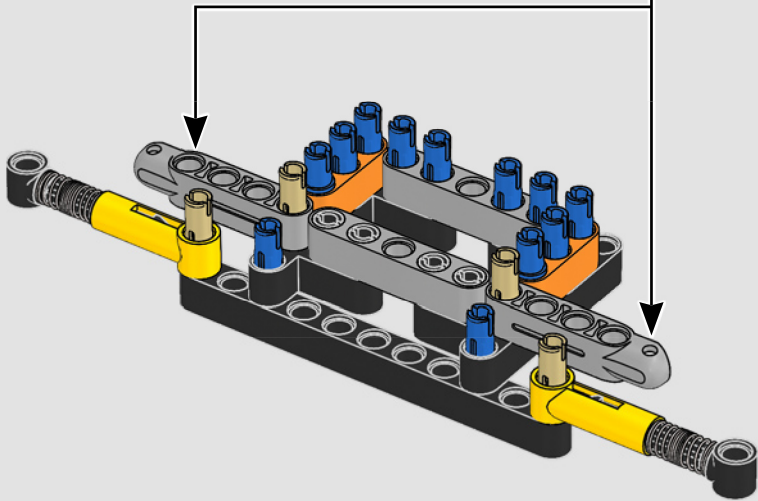
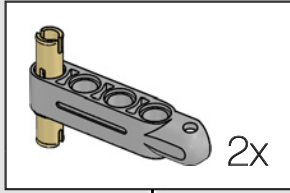
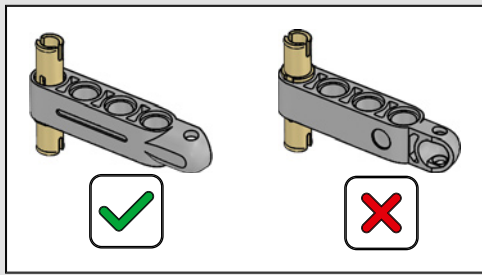

20

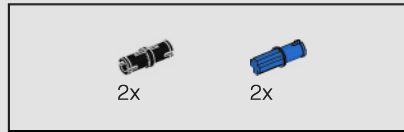
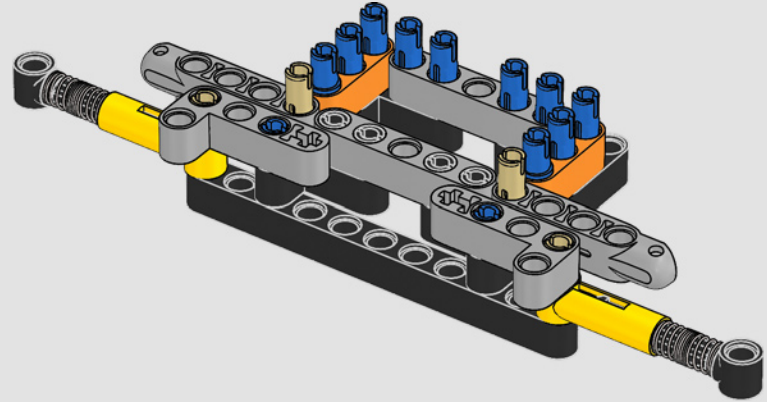

21

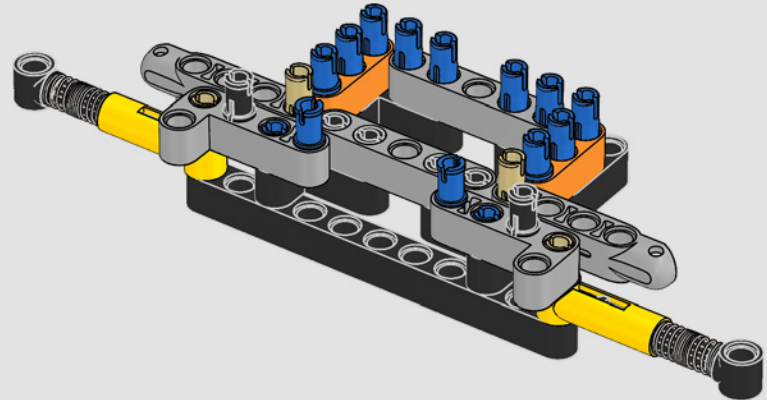

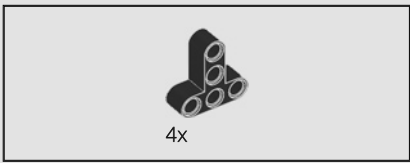

22

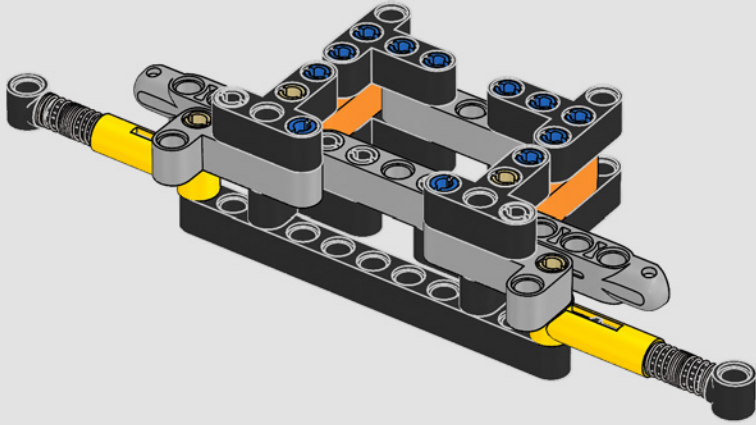

23

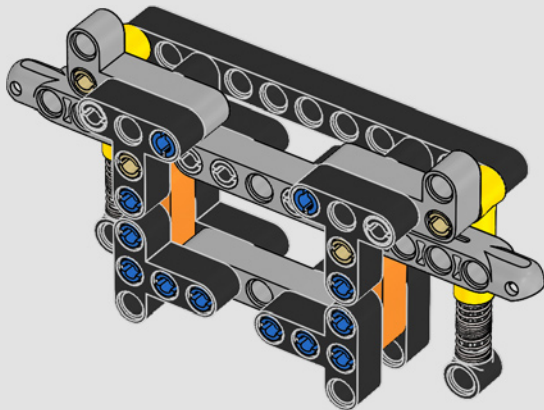

24

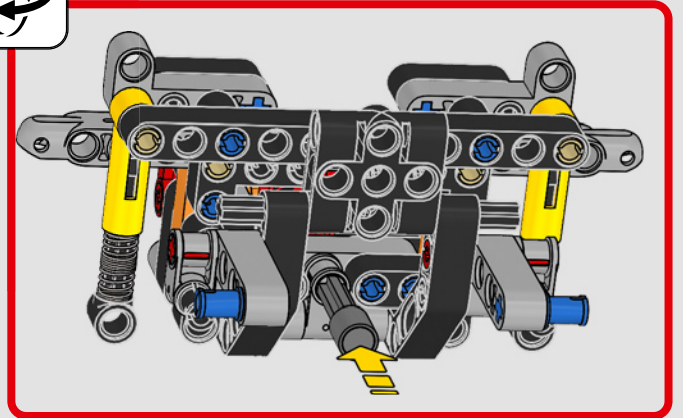
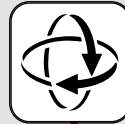
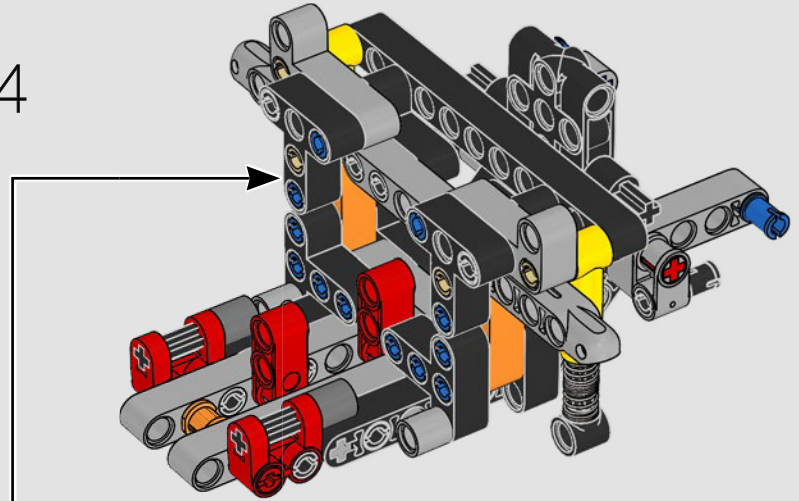

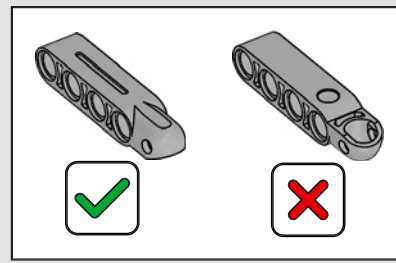
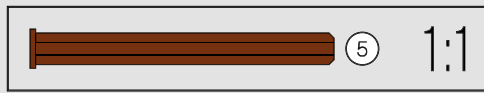
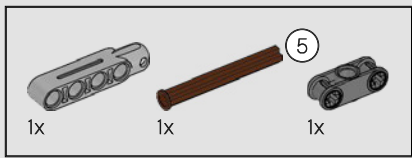

25

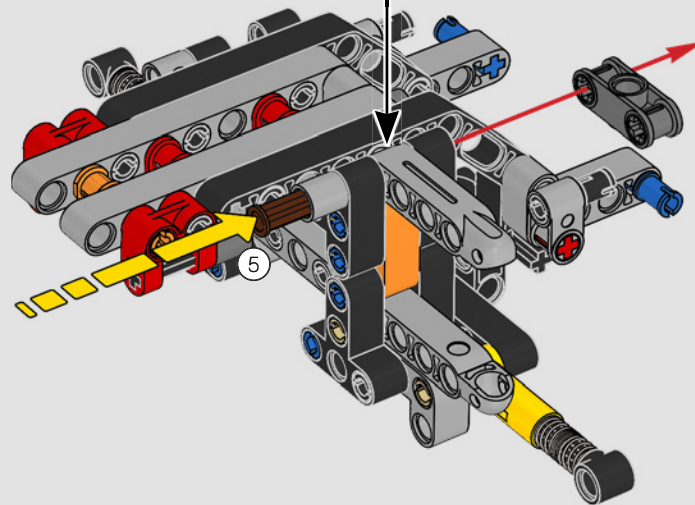
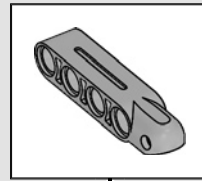



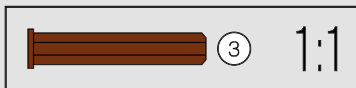
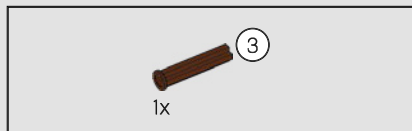

26

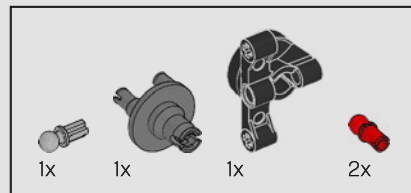
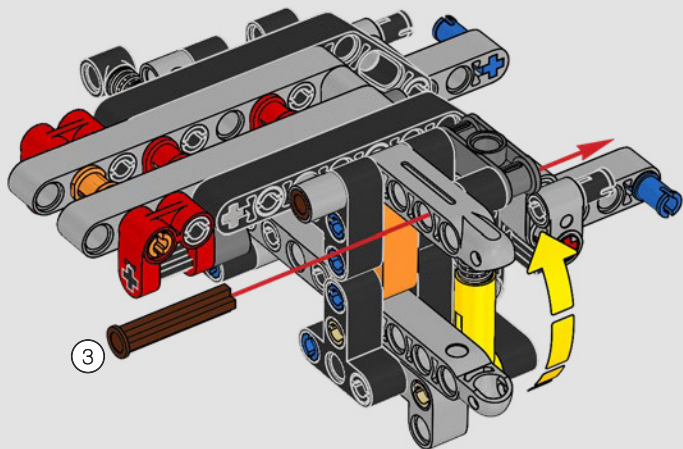

27

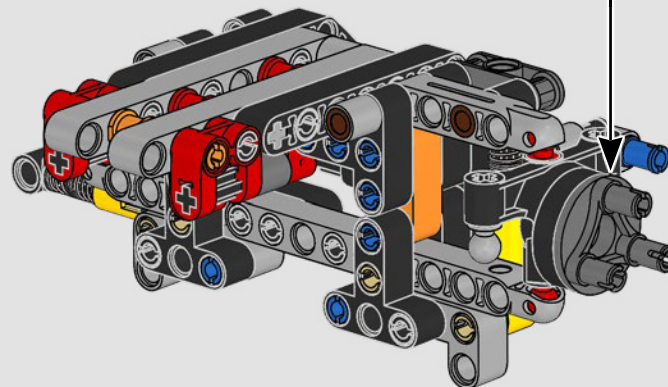
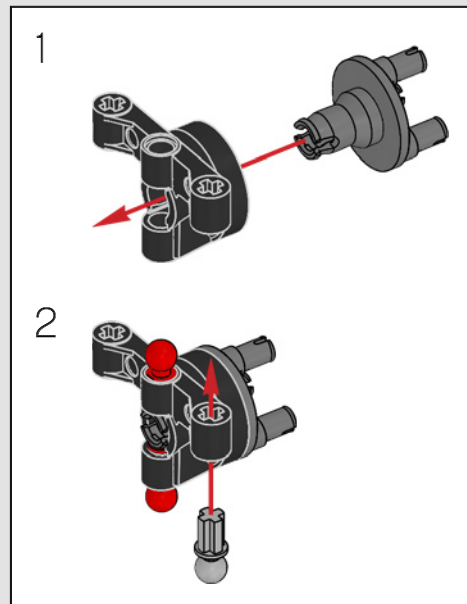

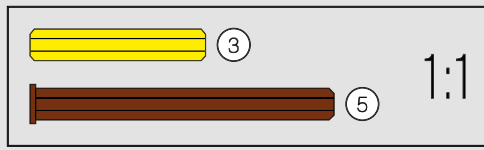
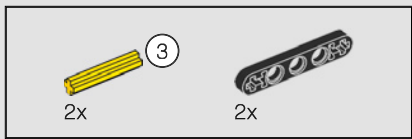

28

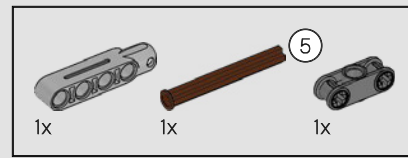
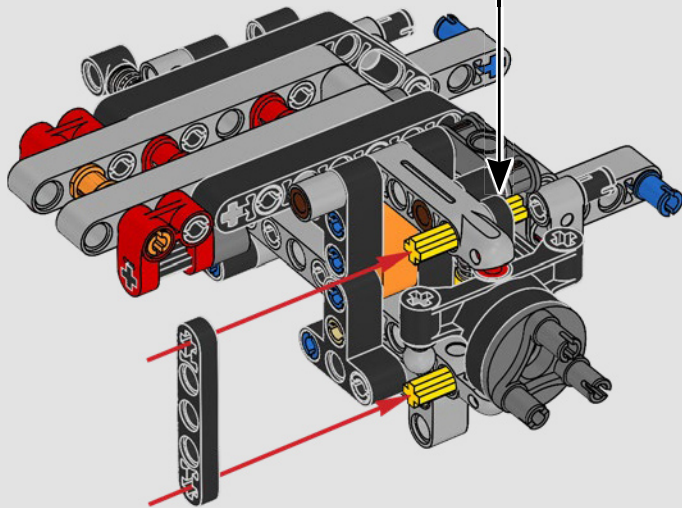
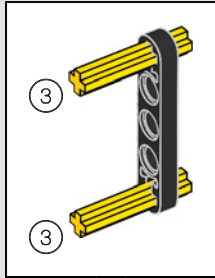

29

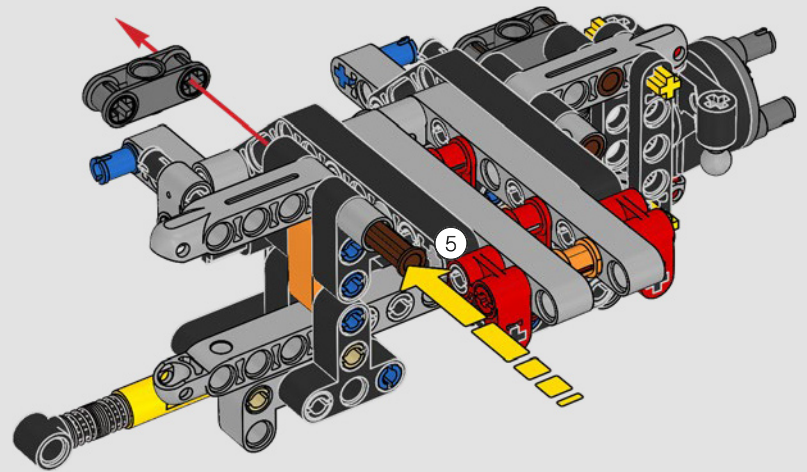
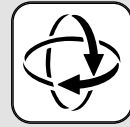

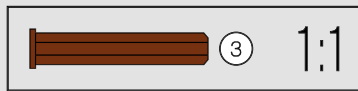
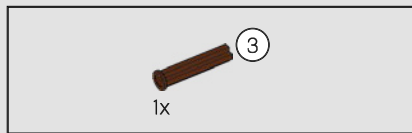

30

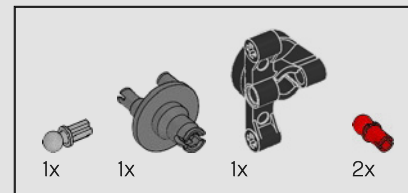
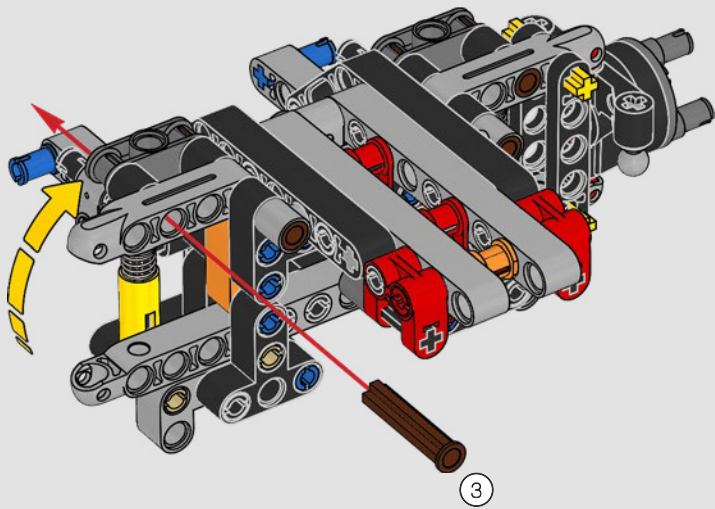

31

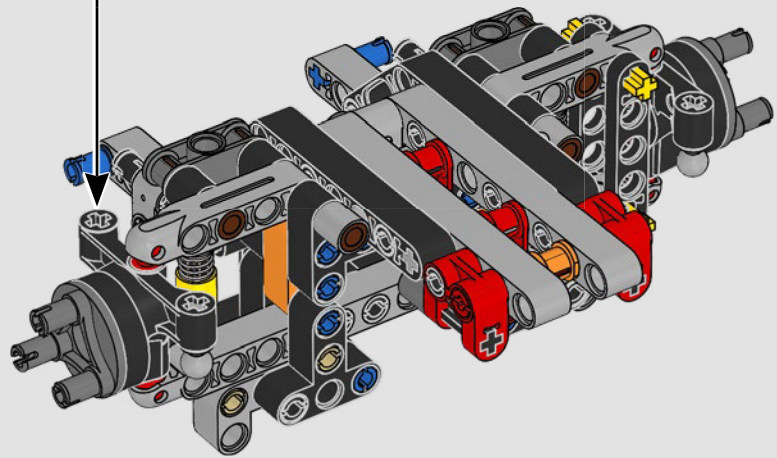
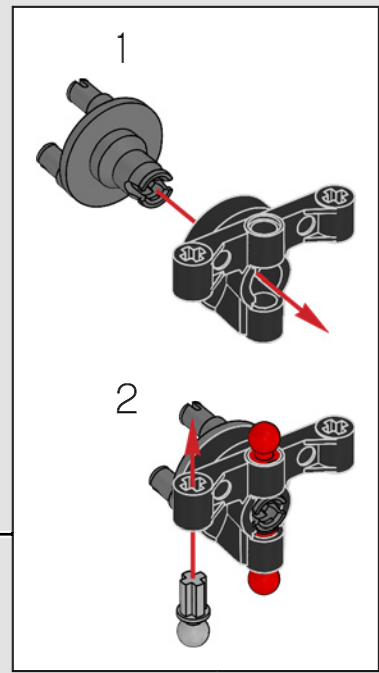

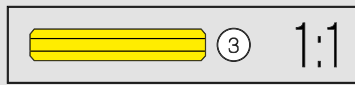
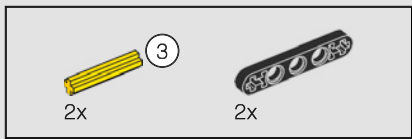

32

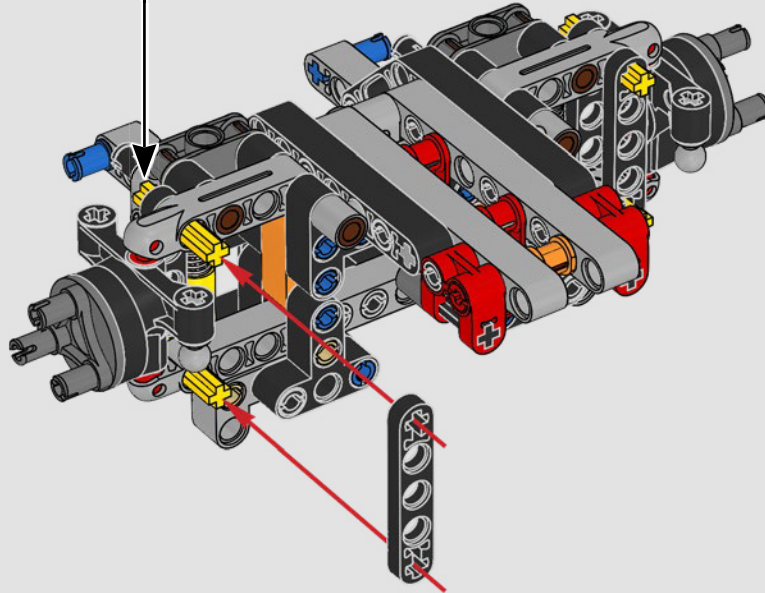
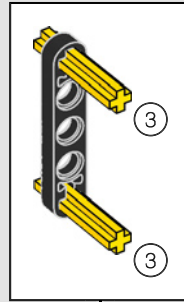

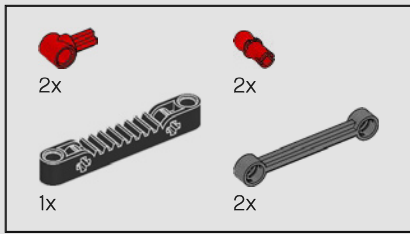

33

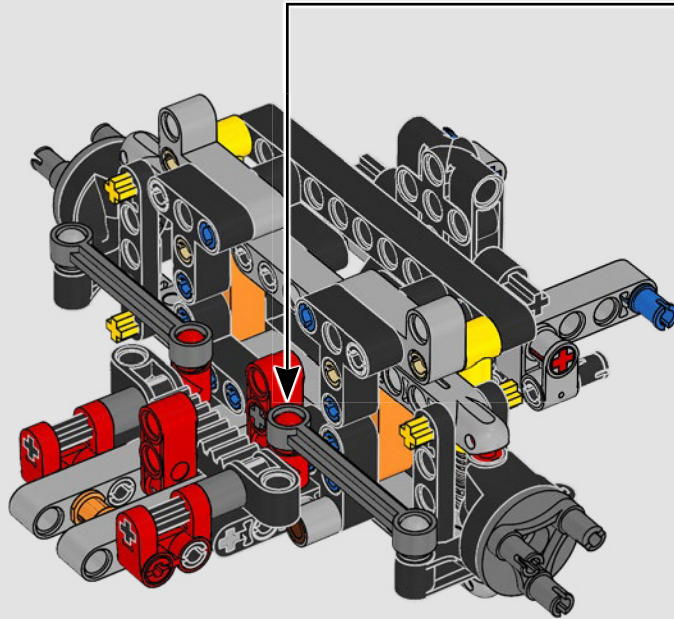
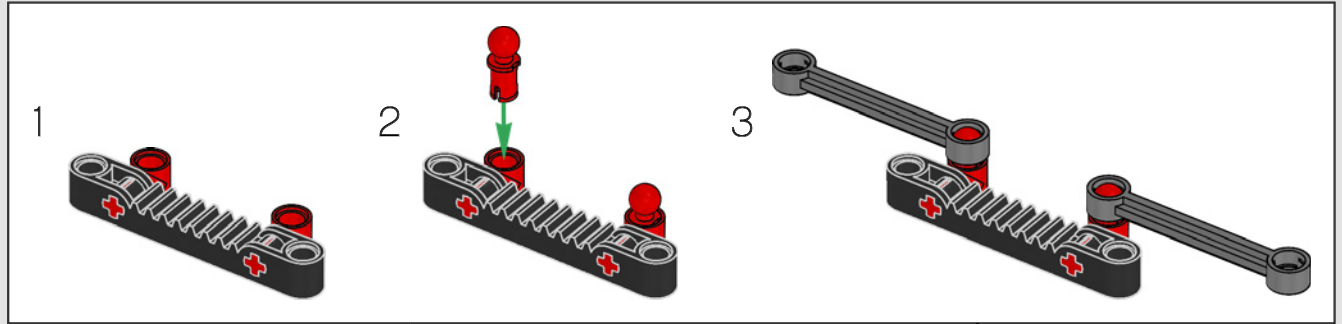

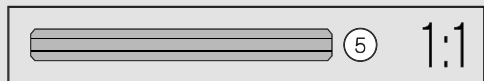
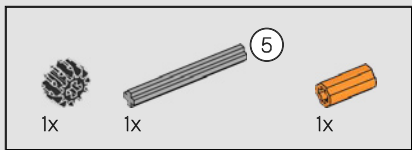

34

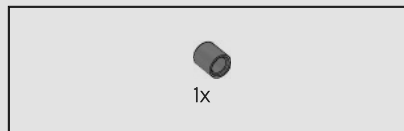
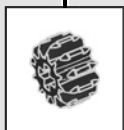
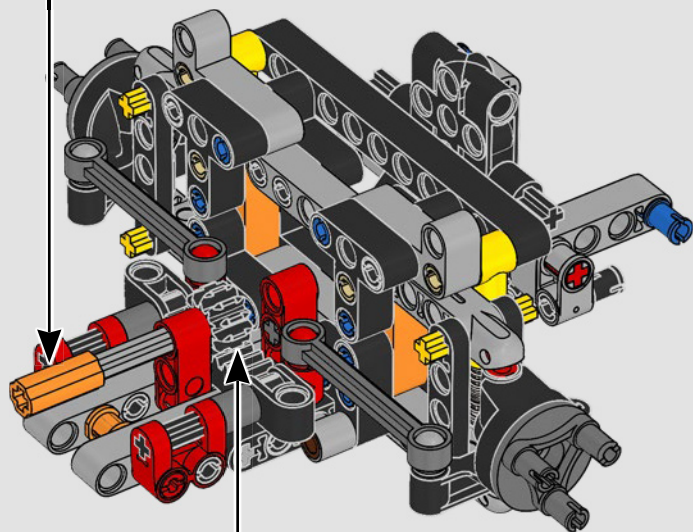
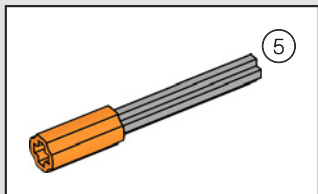

35

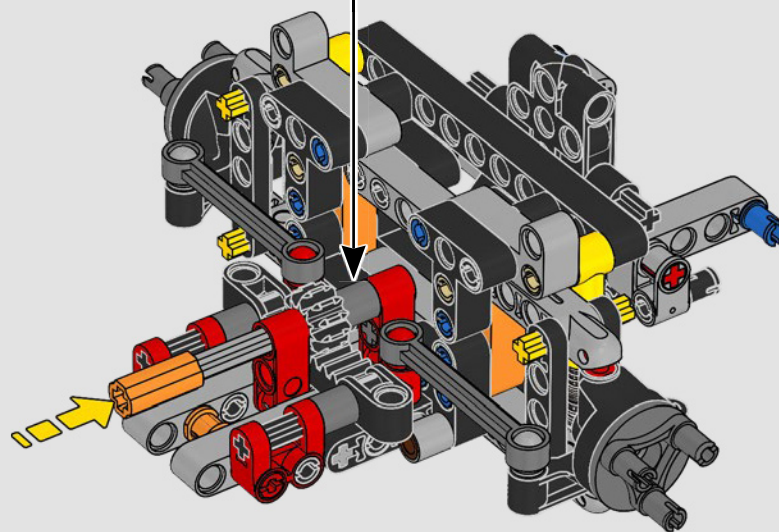

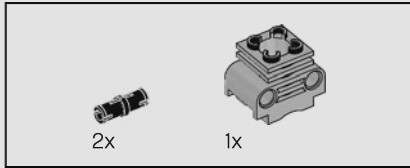
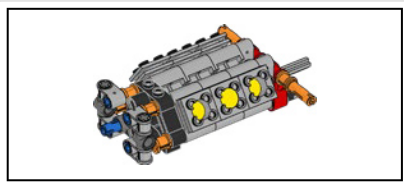

36

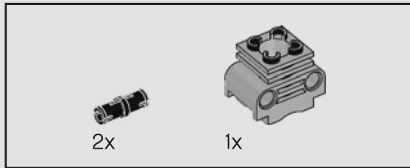
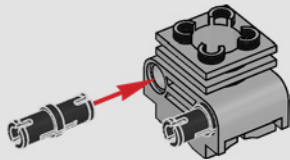

37

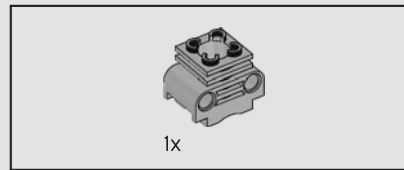
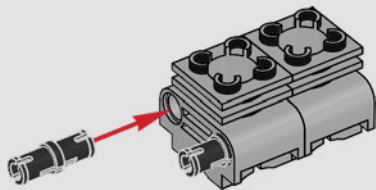

38

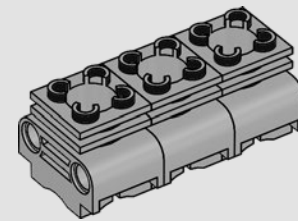

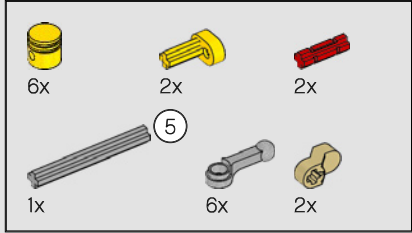
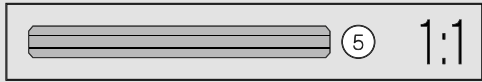
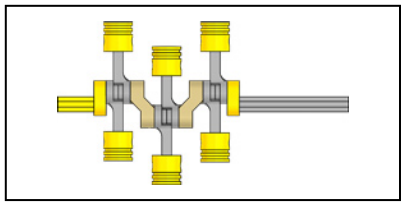

39

1

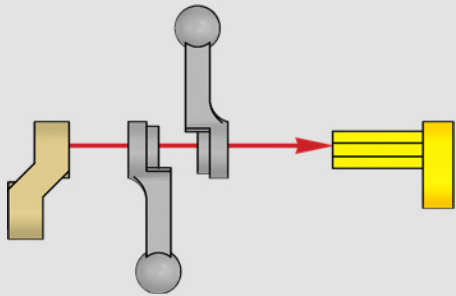

2

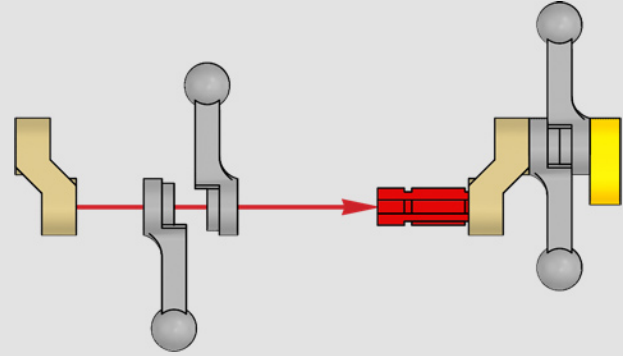

3

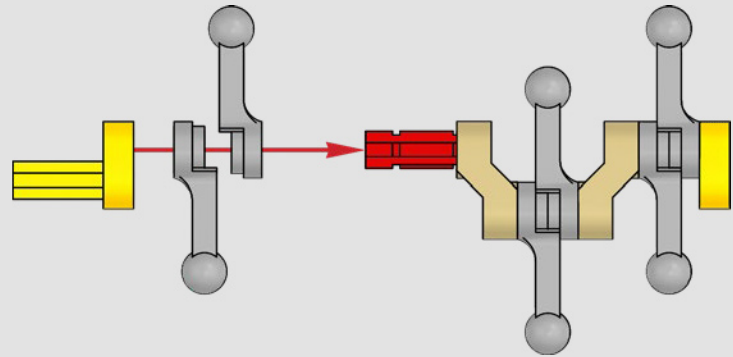



4

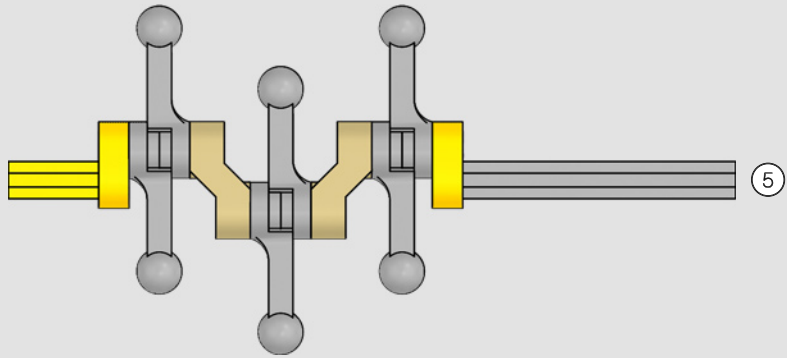

5

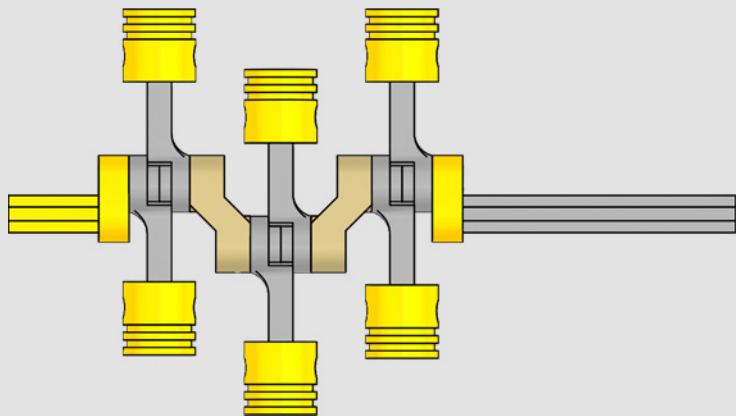

1:1

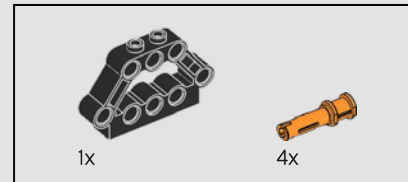
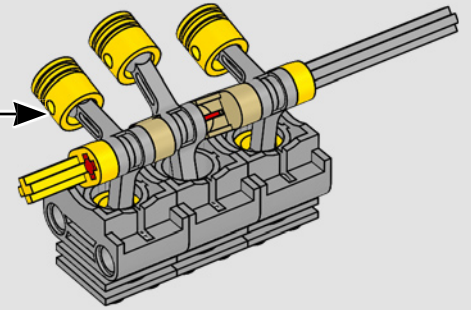
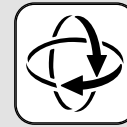

40

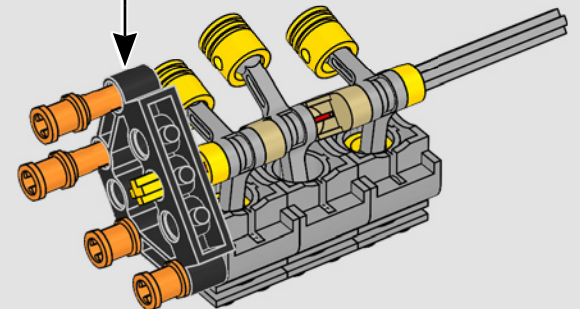
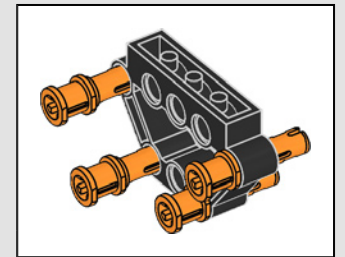

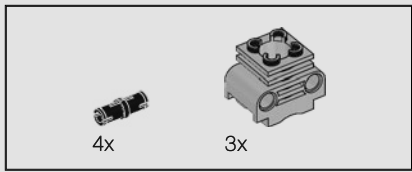

41

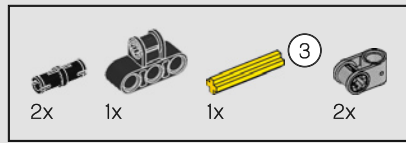
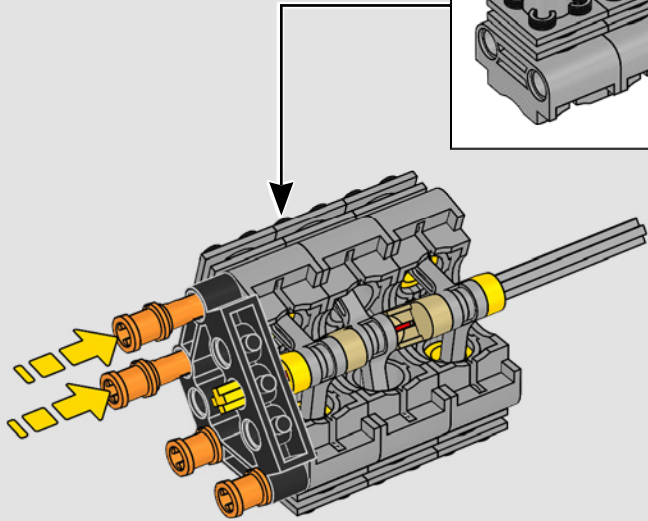
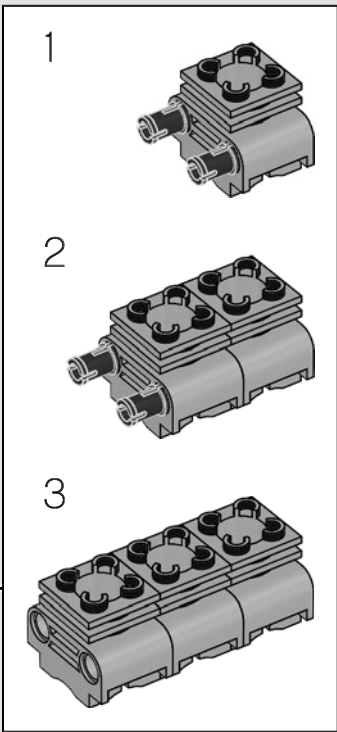

42

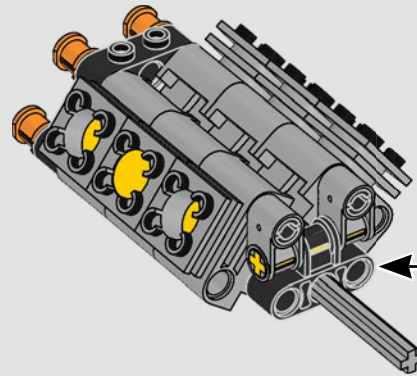
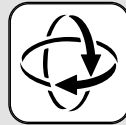
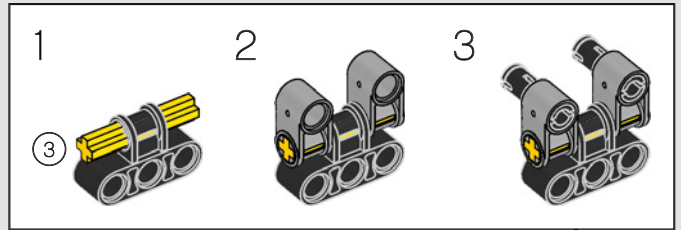
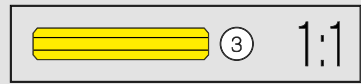

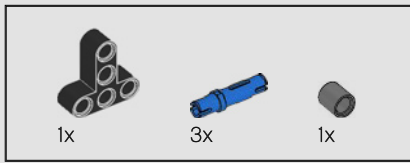

43

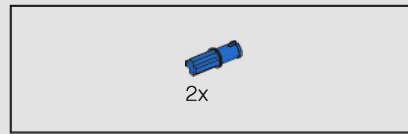
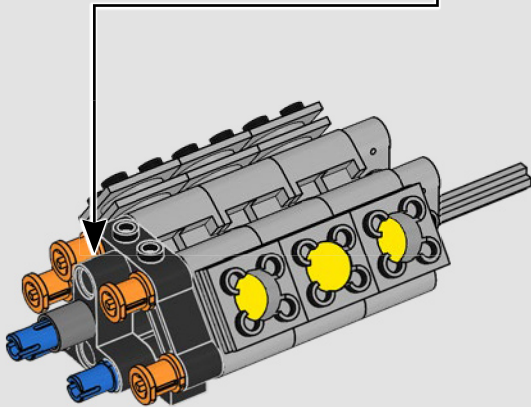
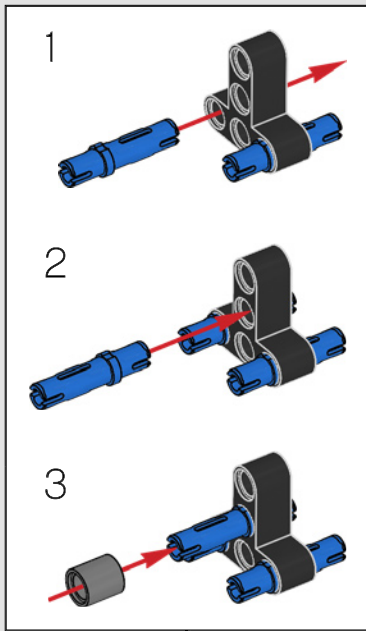

44

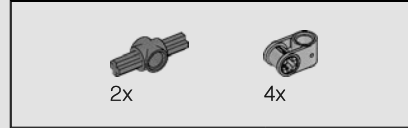
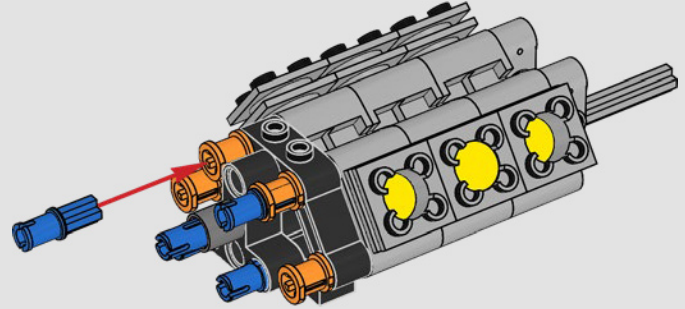

45

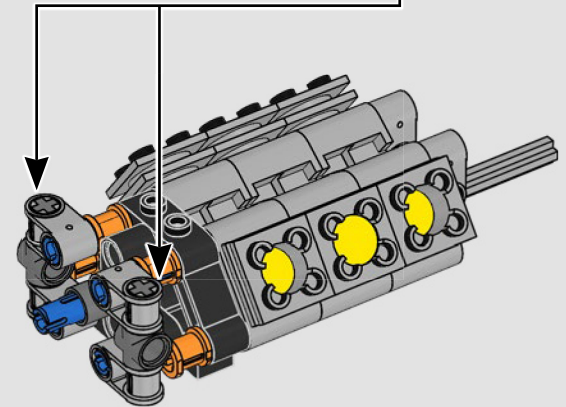
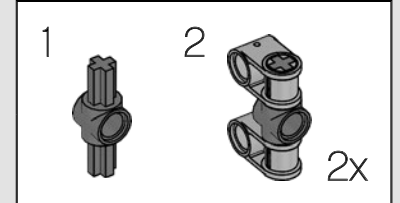

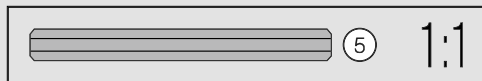
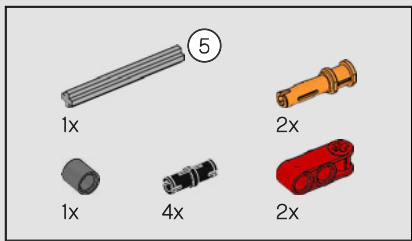

46

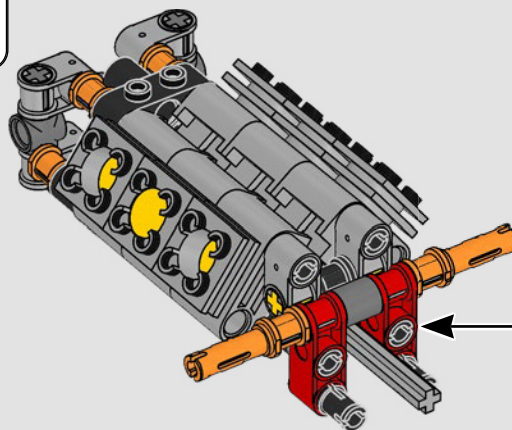
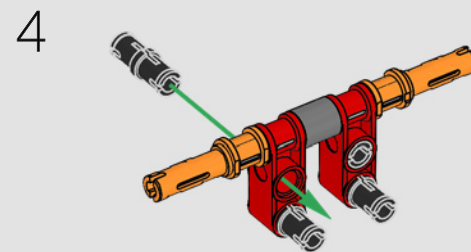
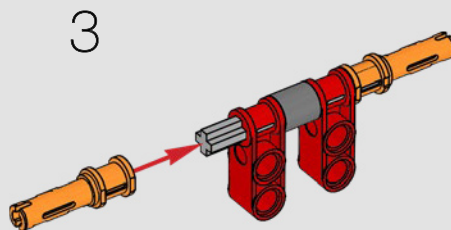
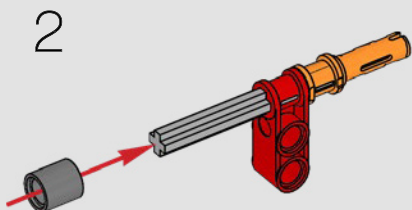
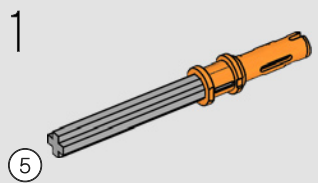

47

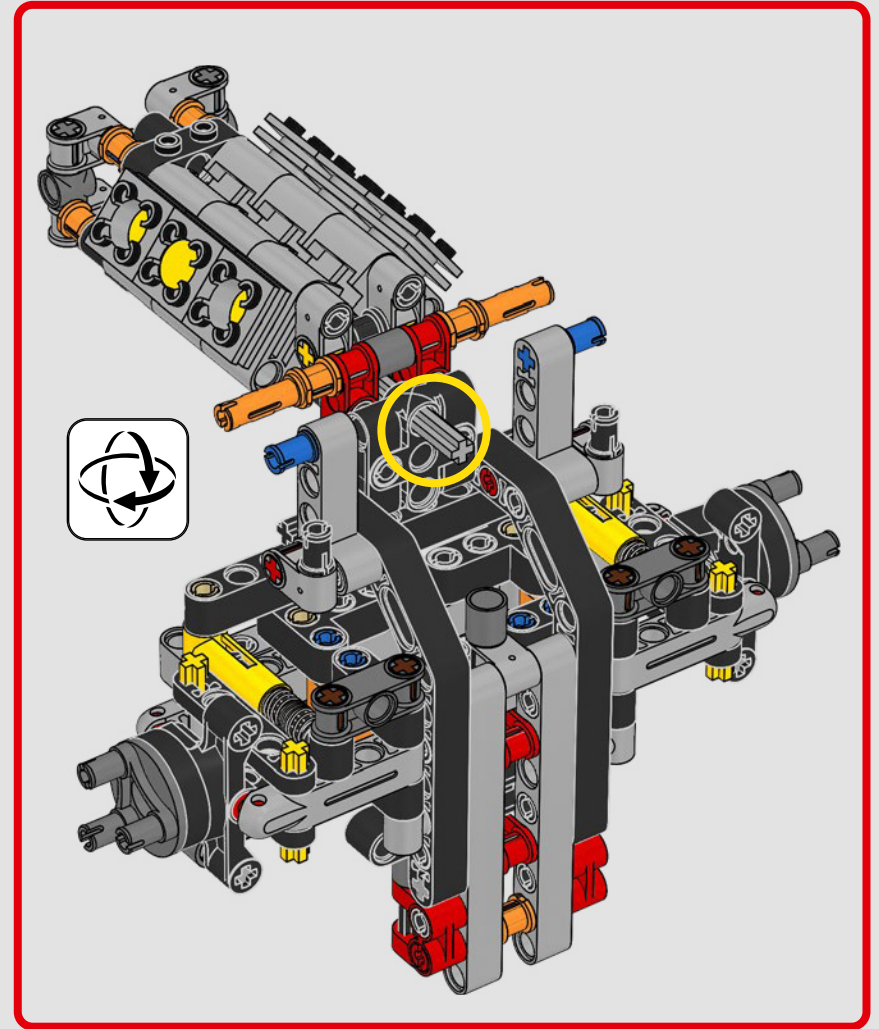
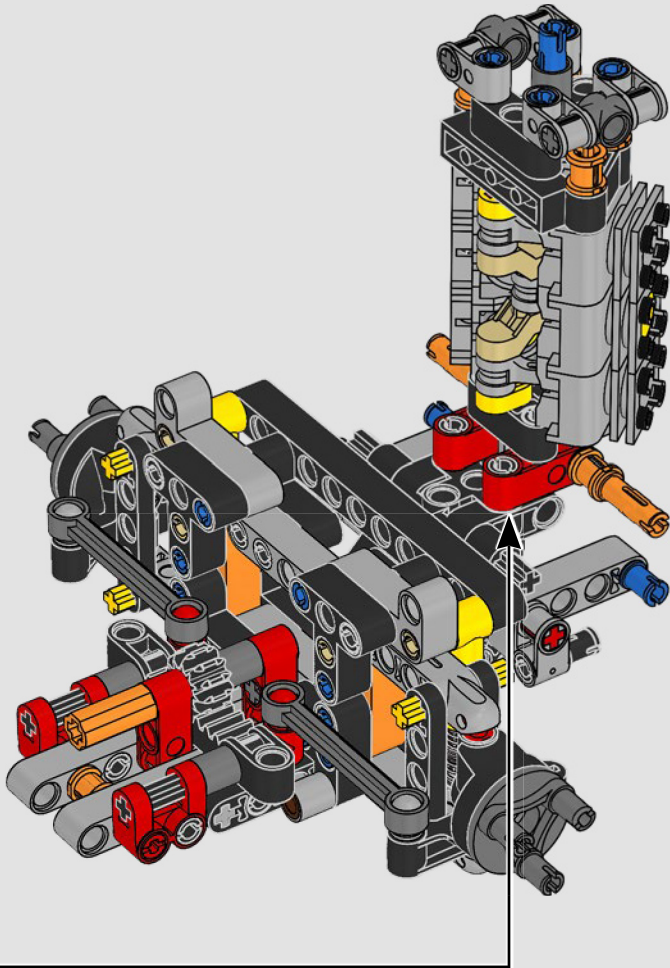



1x

48

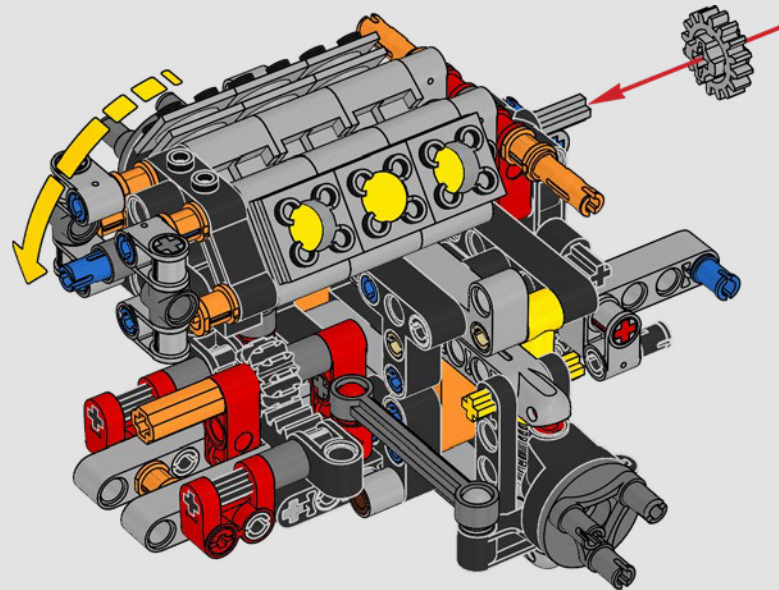

*Sous le capot se trouve un moteur V6 biturbo de 3,5 litres à 24 soupapes, avec la bicarburation et l'injection directe de Ford, ainsi qu'une boîte de vitesses automatique à 10 vitesses.*

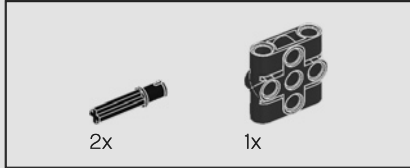
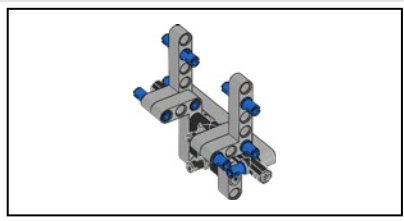

49

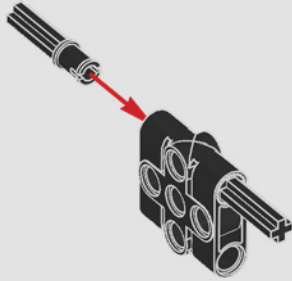

50

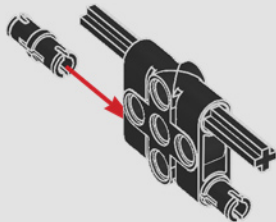

51

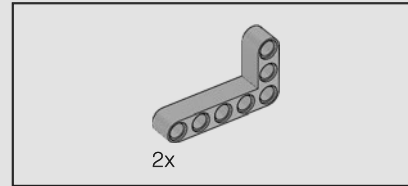
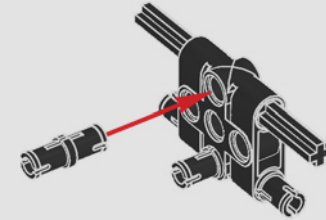

52

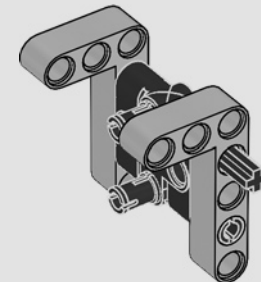

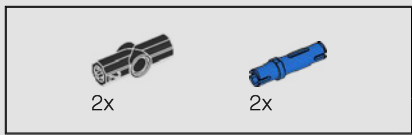

53

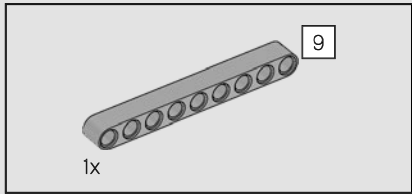
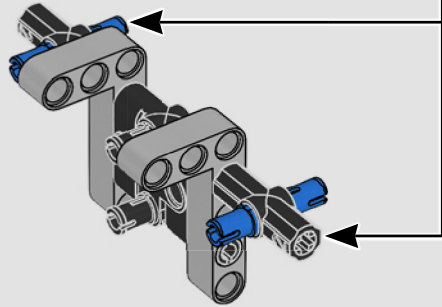
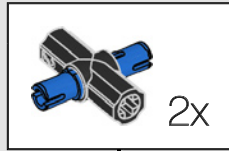

54

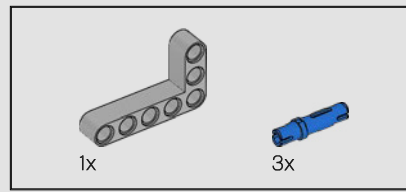
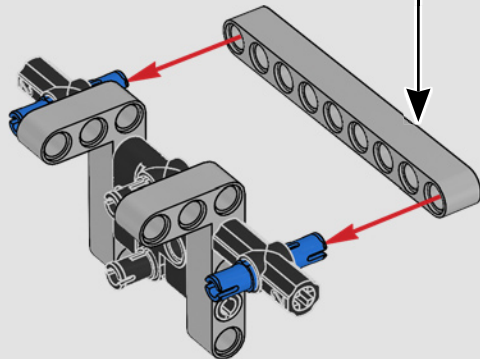
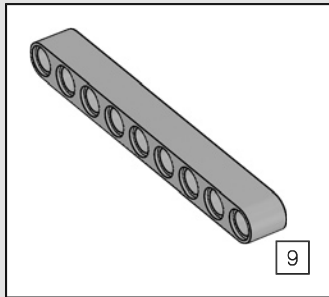

55

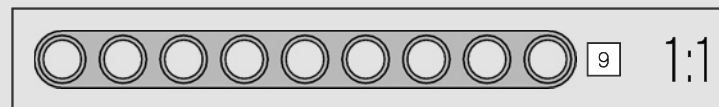
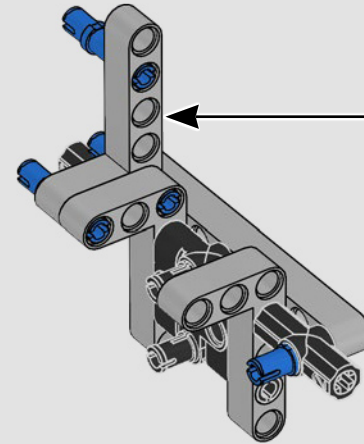
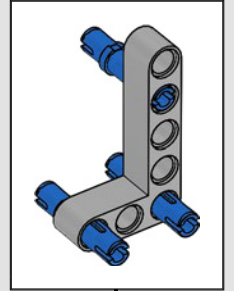



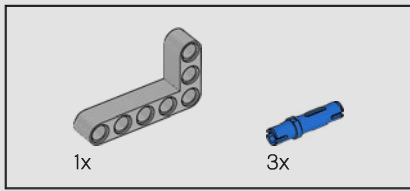

56

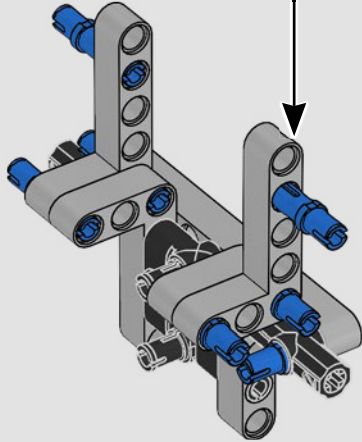
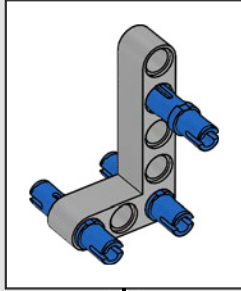

57

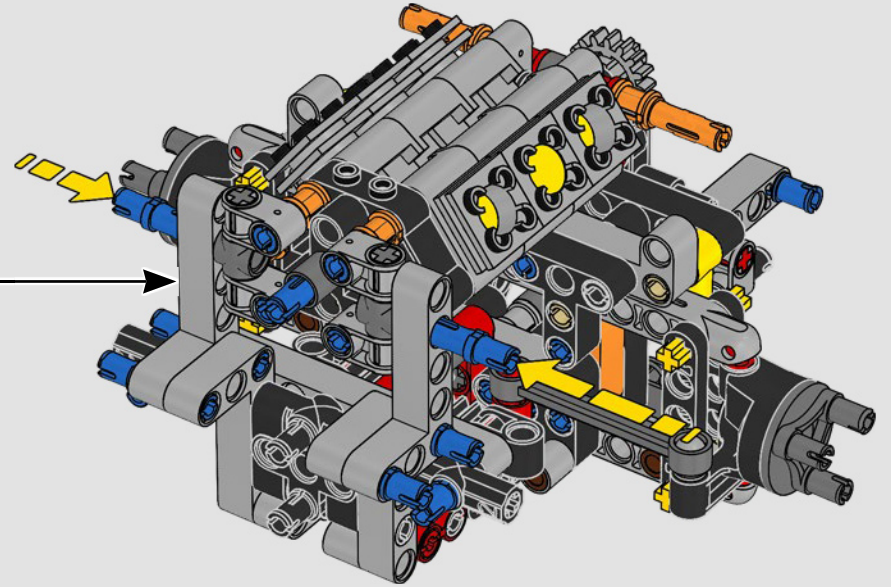

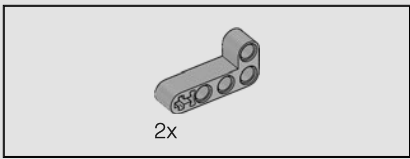

58

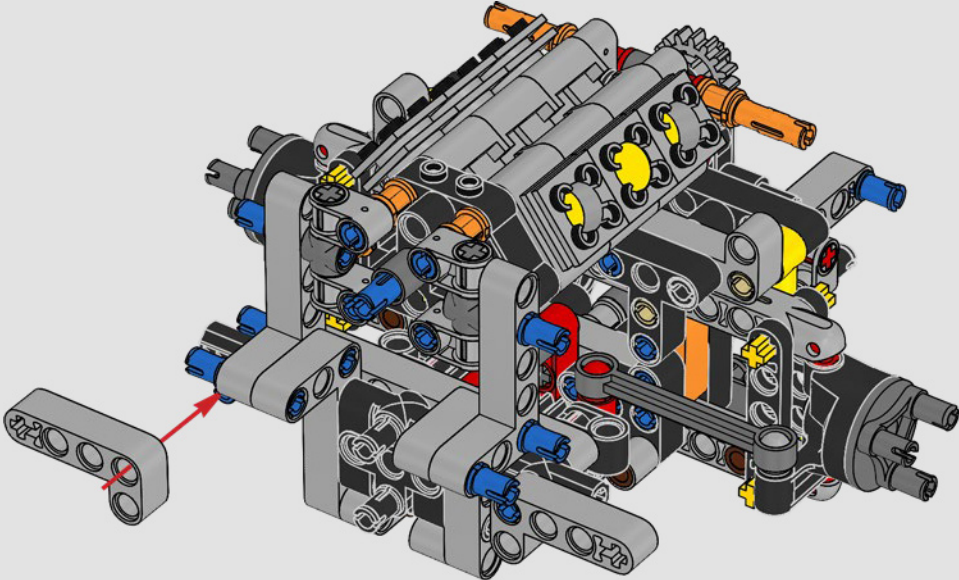

59

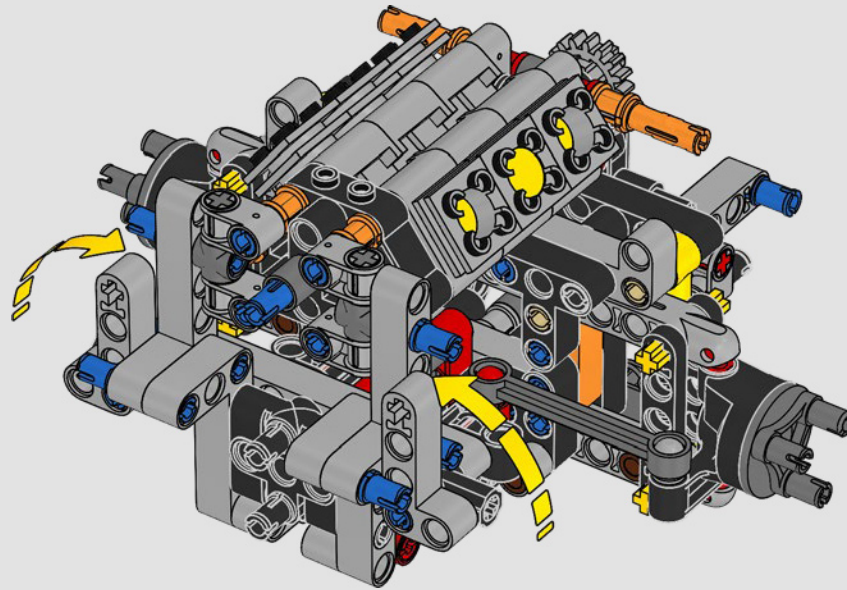

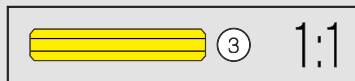
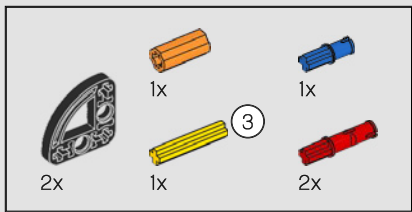

60

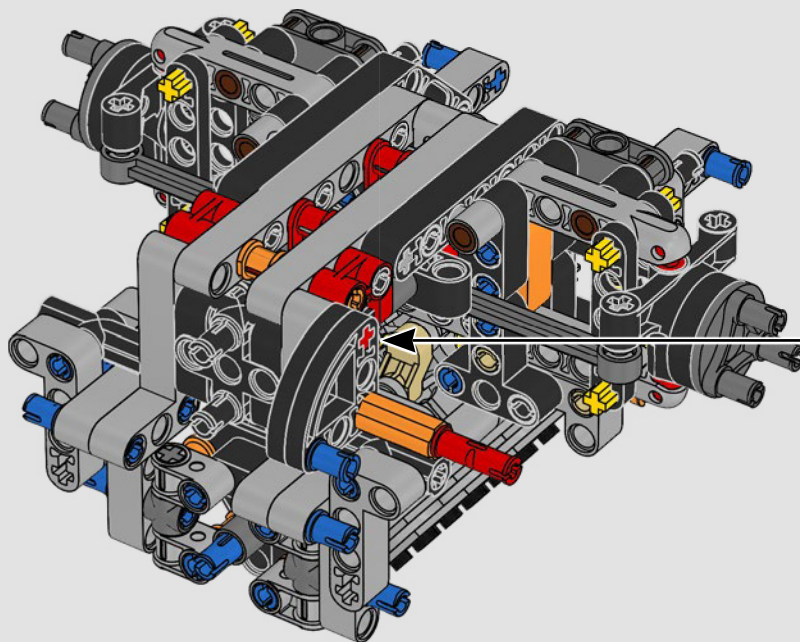
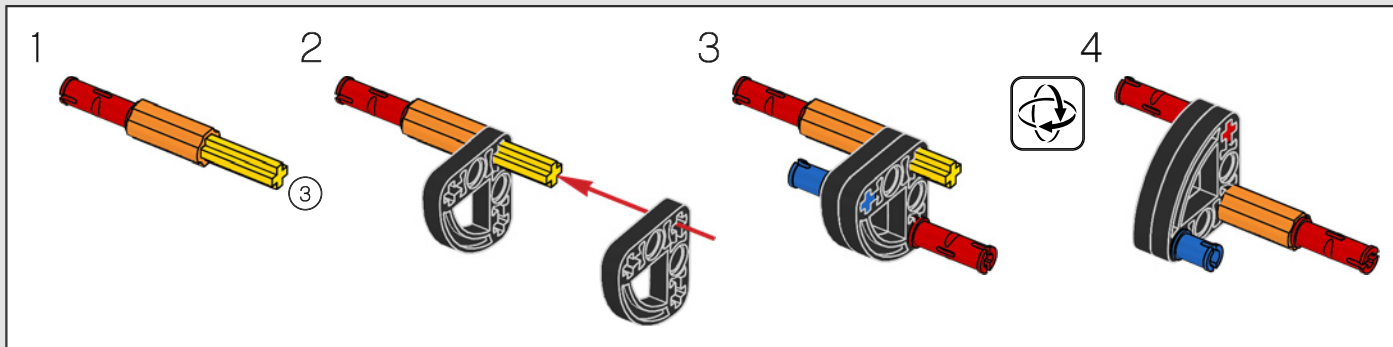

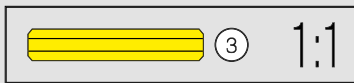
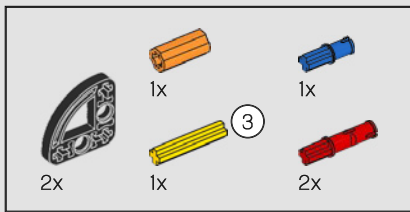

61

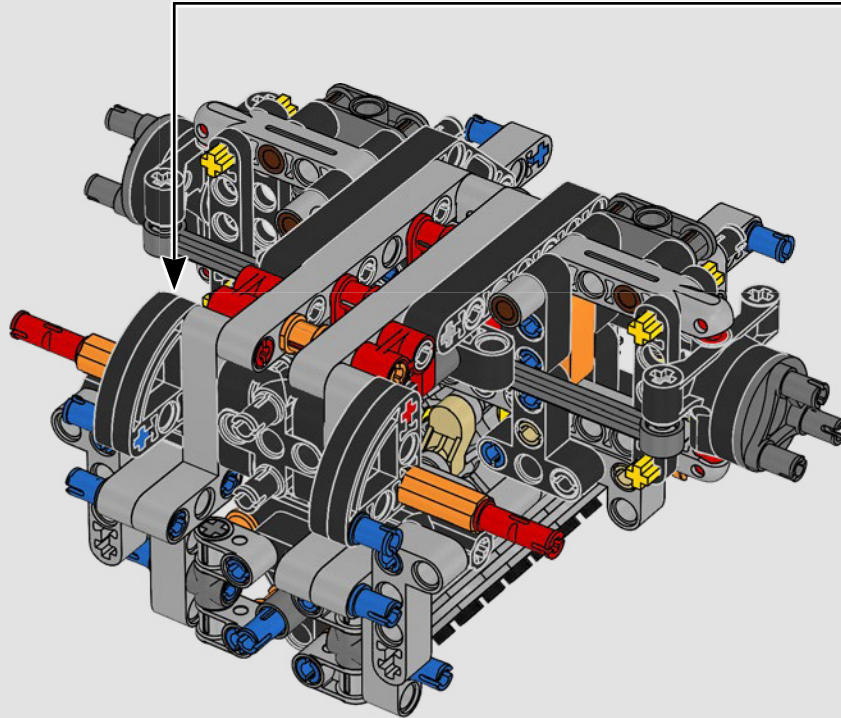
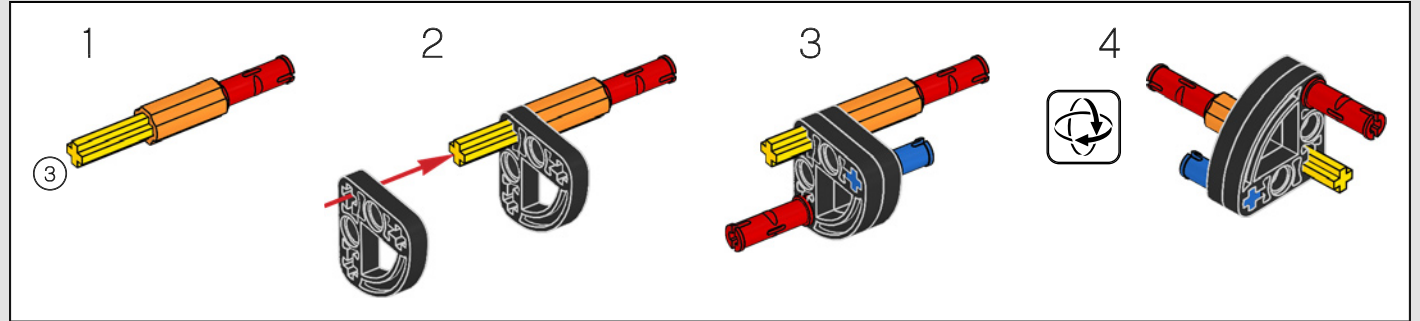

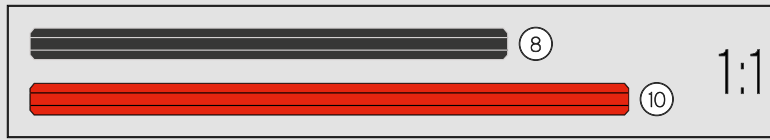
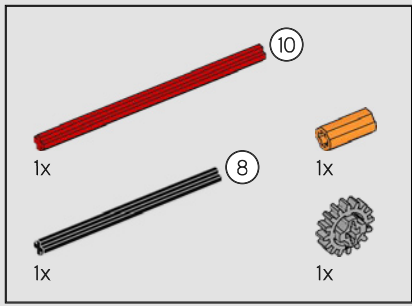

62

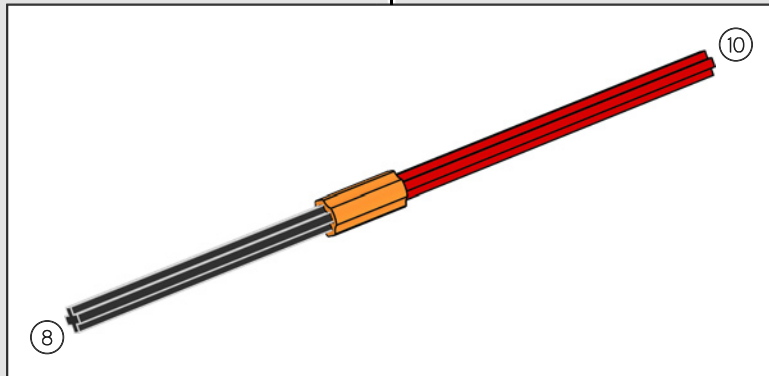
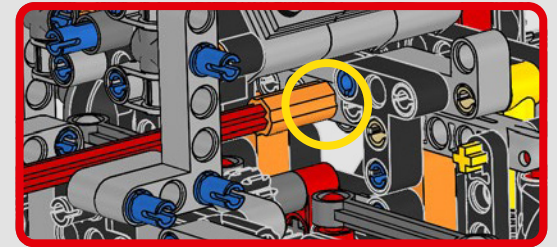
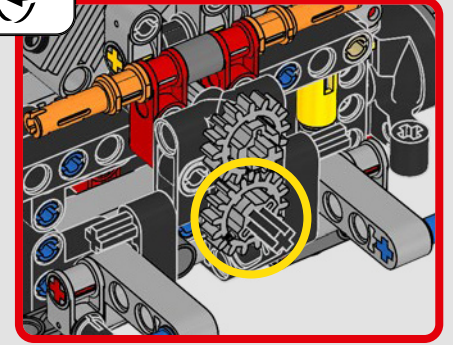
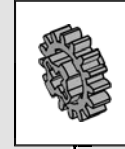
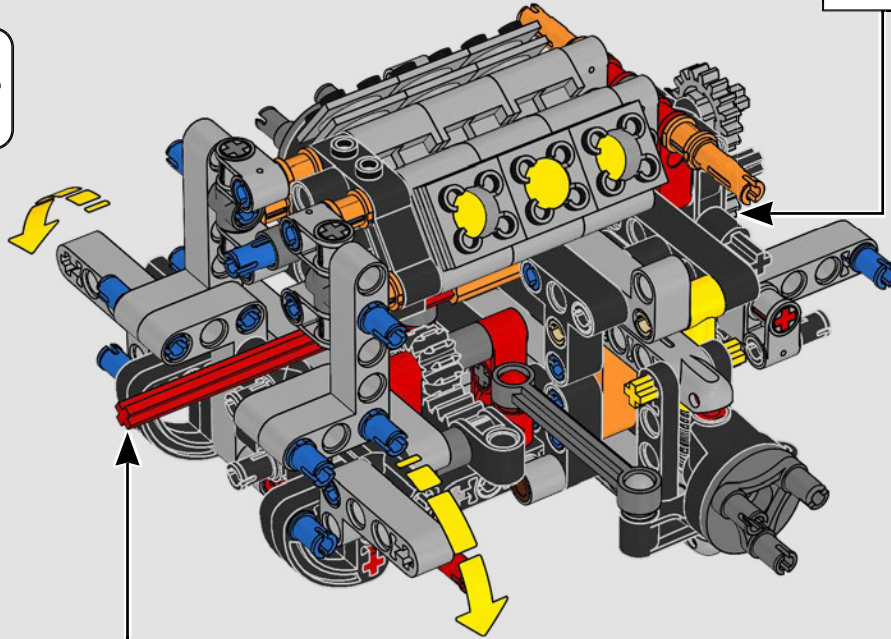

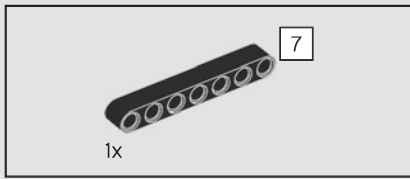

63

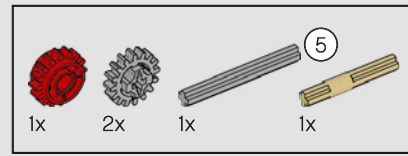
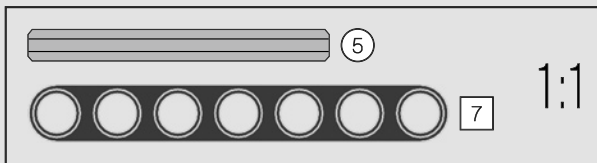
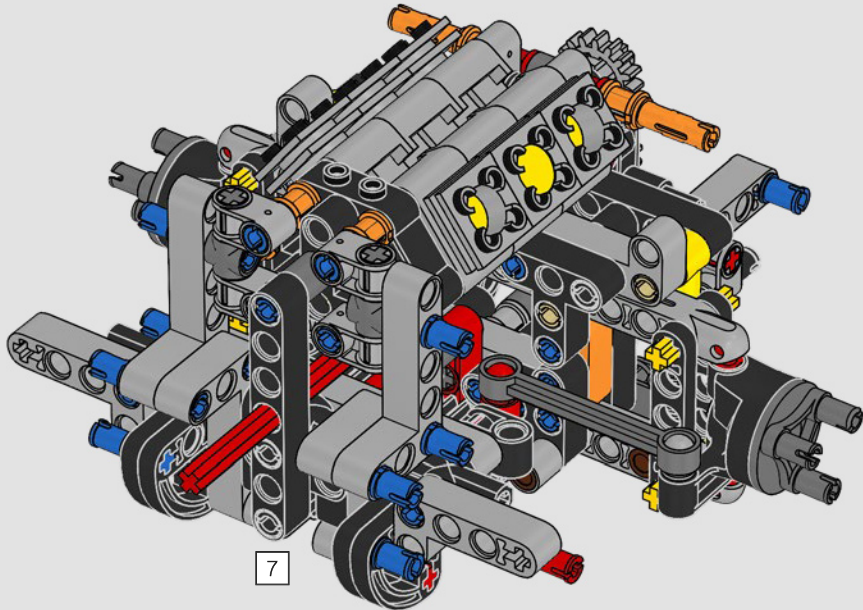

64

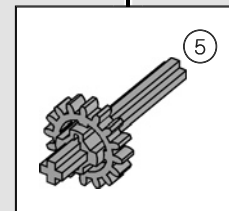
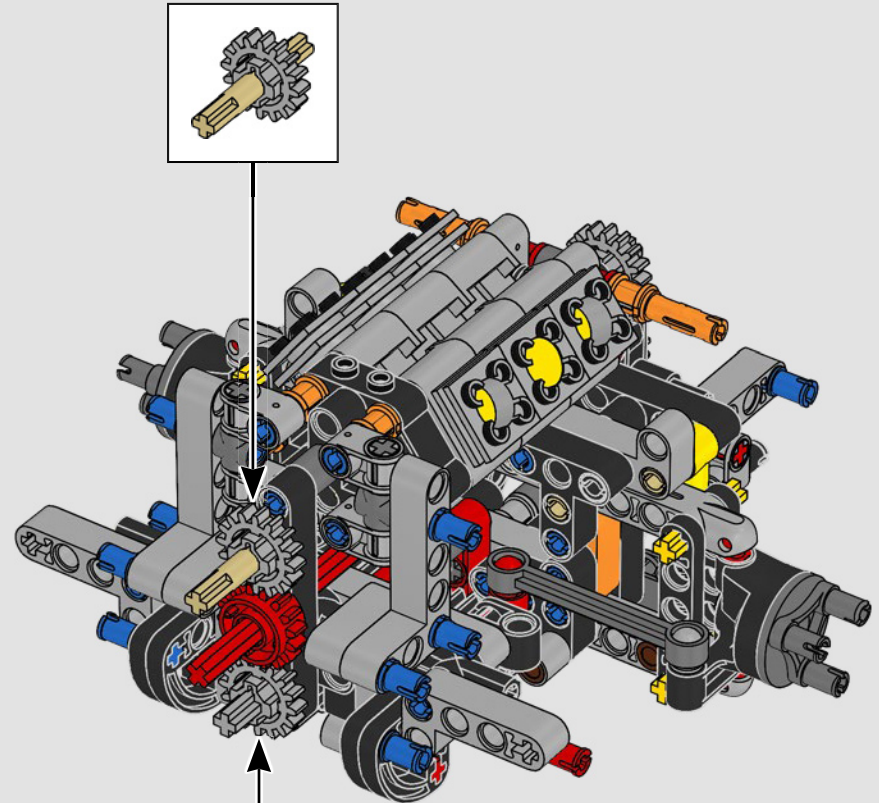

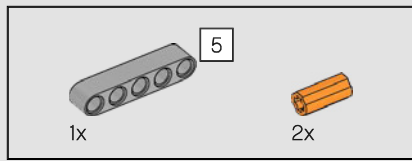

65

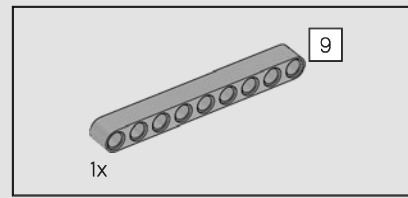
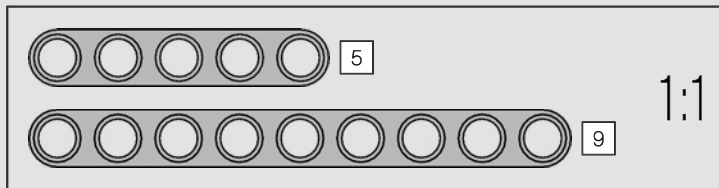
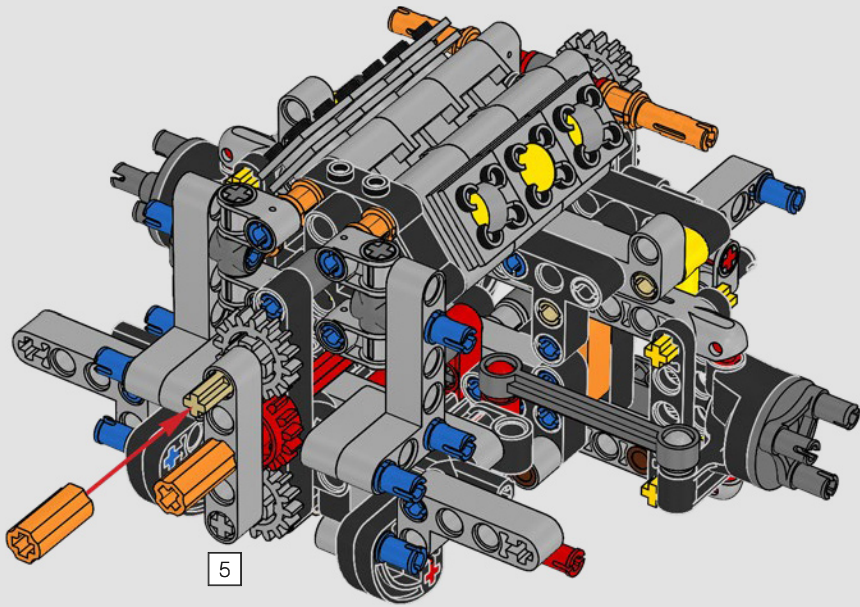

66

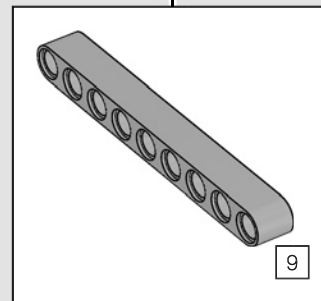
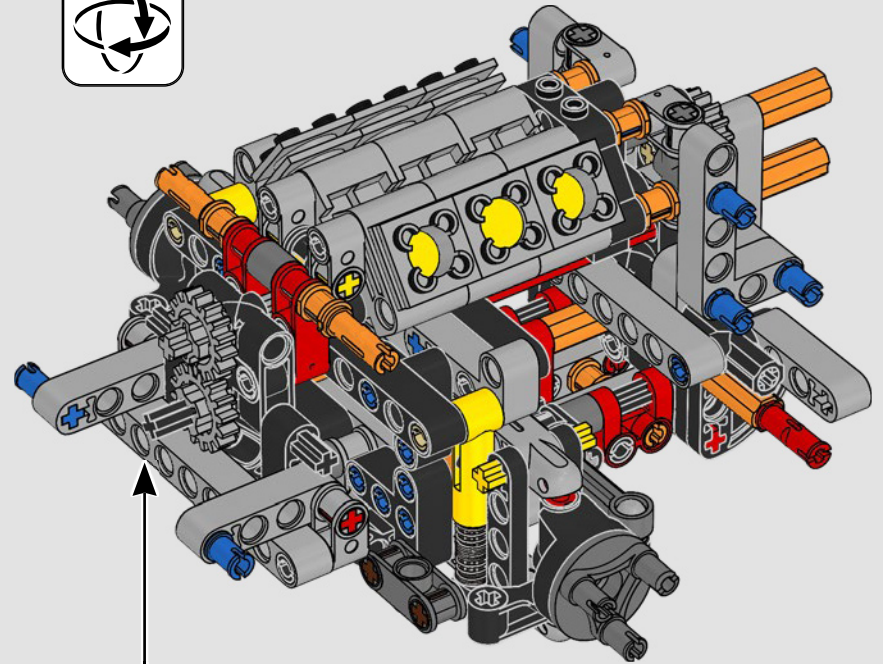
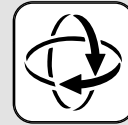



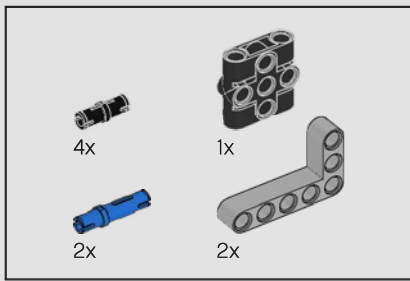

67

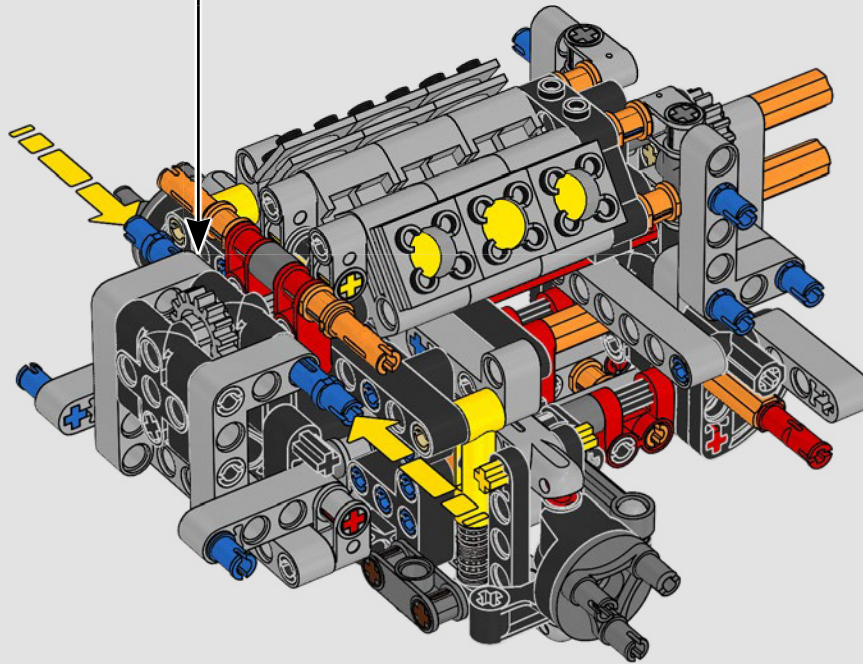
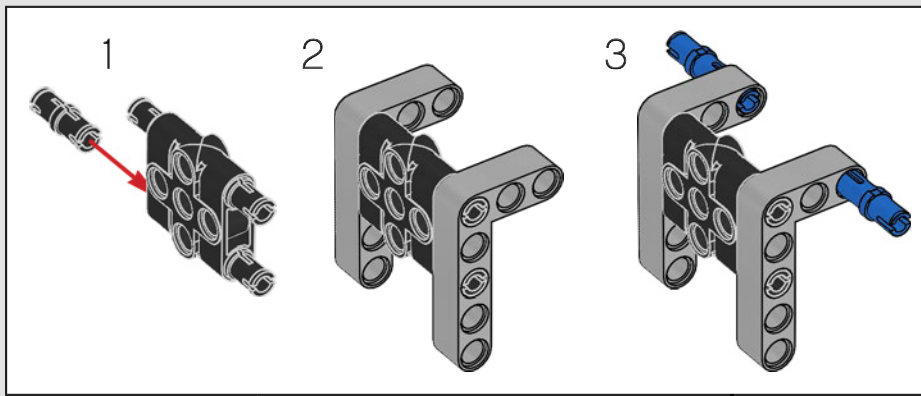

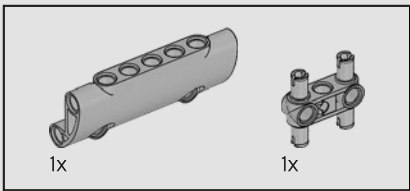

68

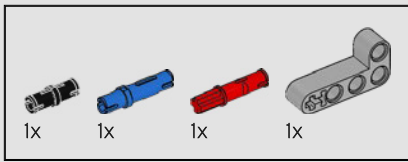
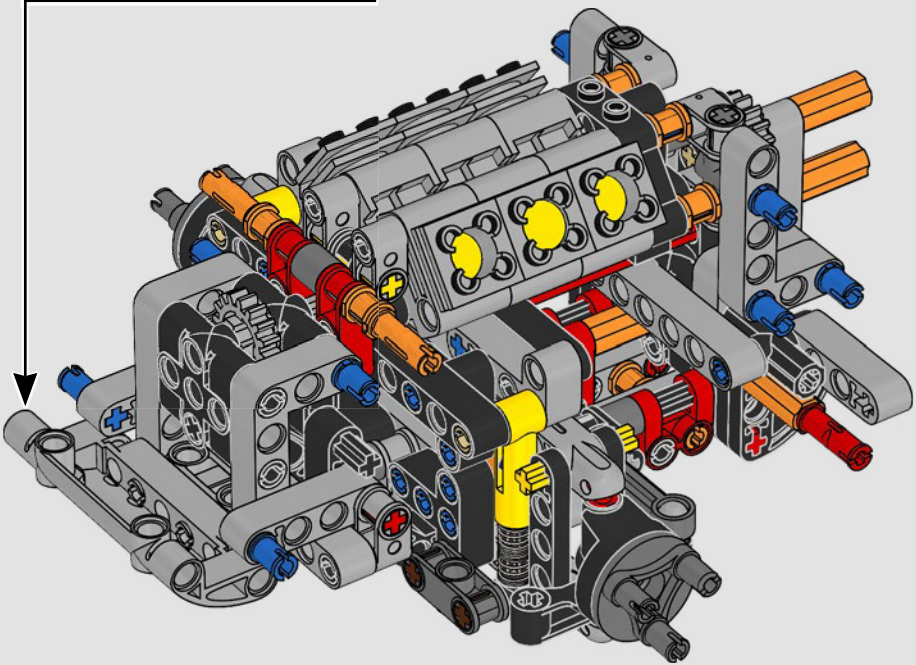
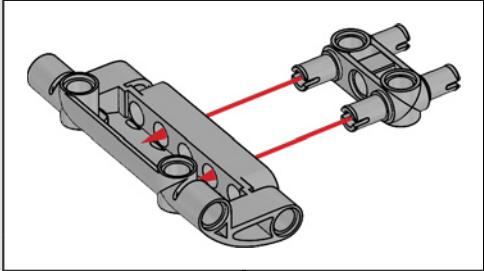

69

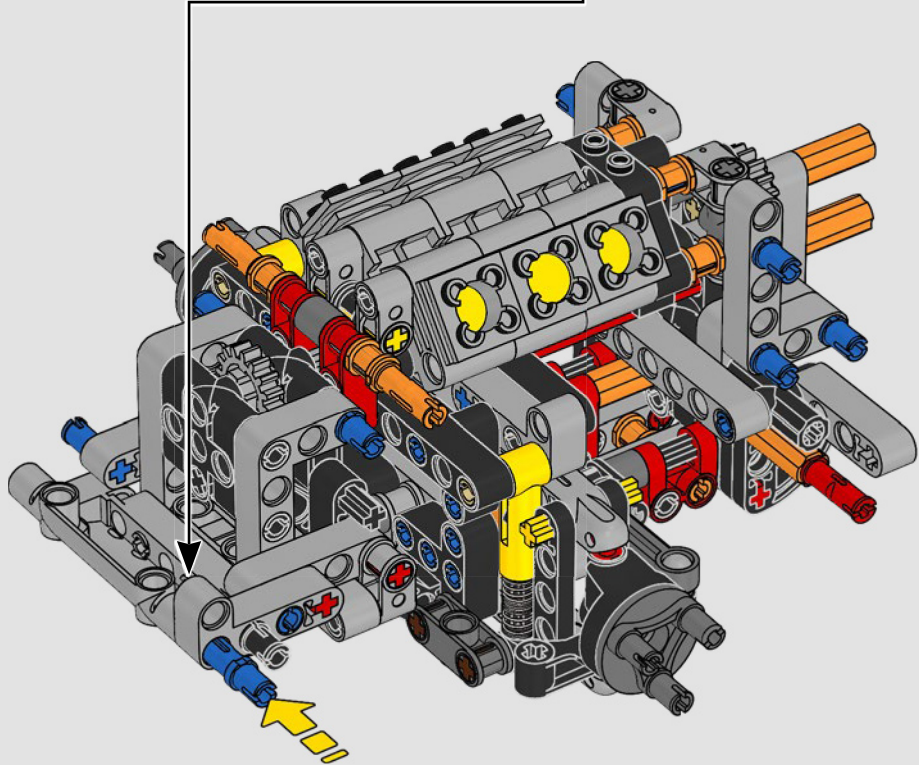
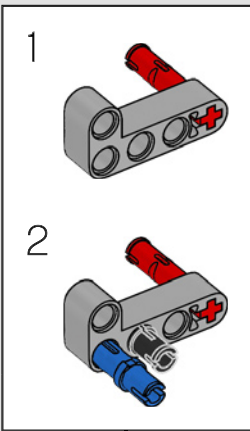

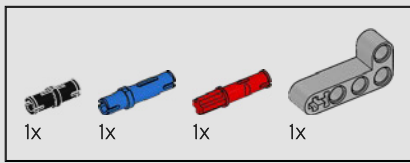

70

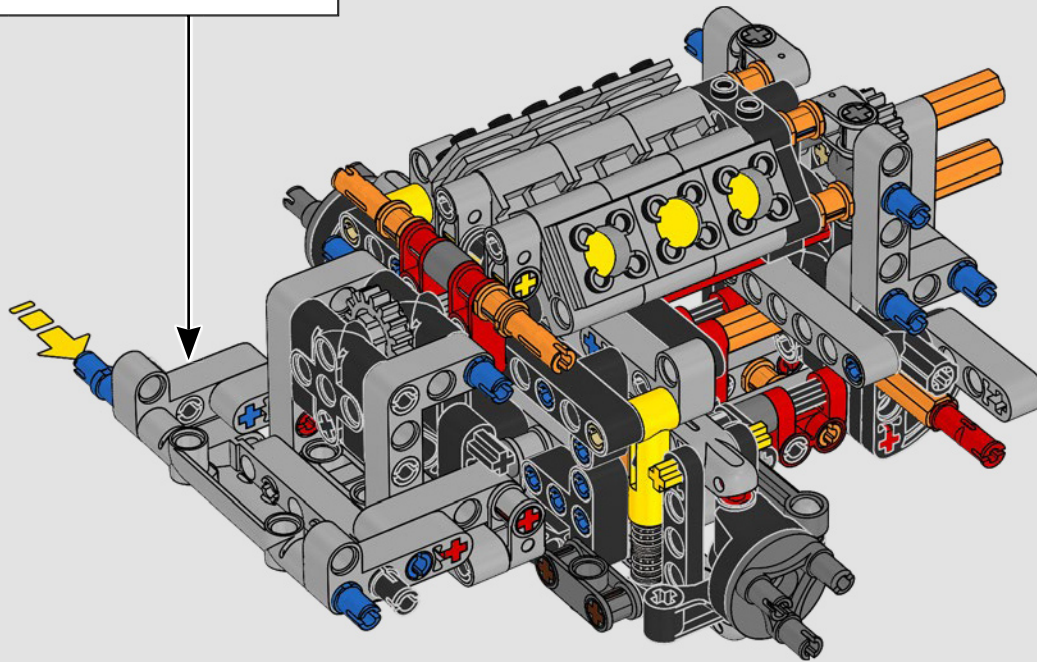
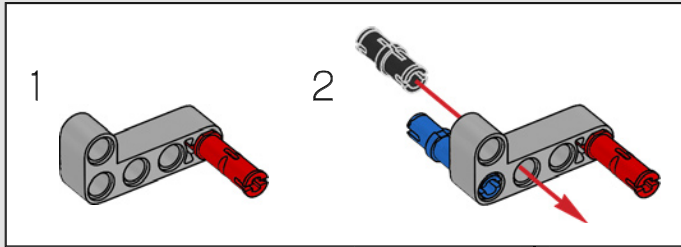

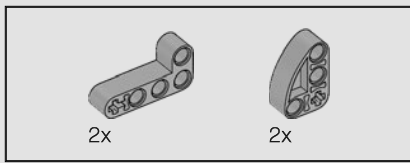

71

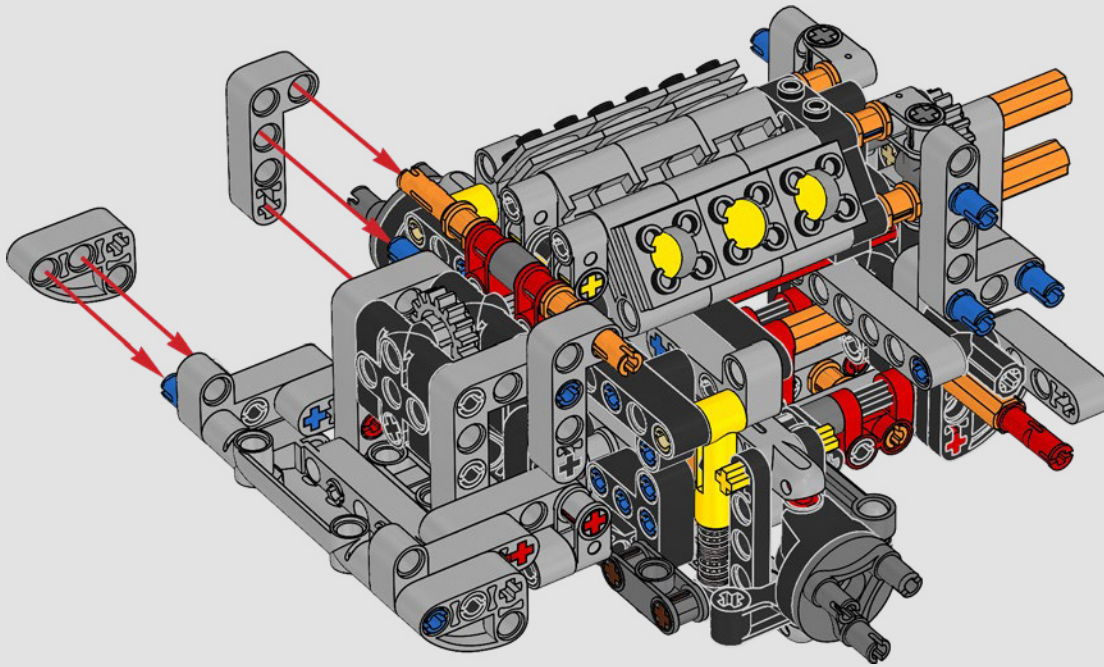

*Conçu pour un usage tout-terrain, le Raptor est équipé en série de quatre roues motrices.*

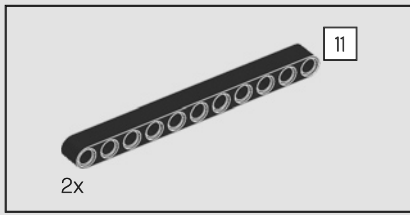

72

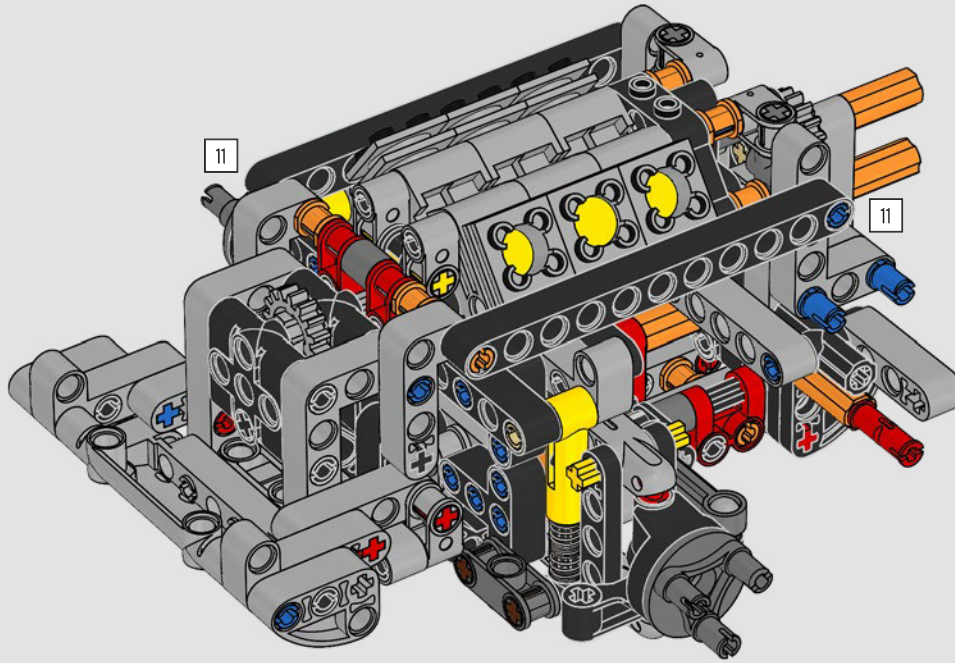

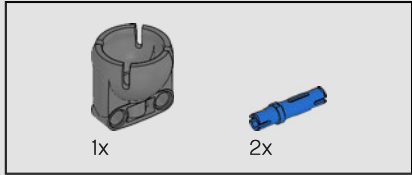
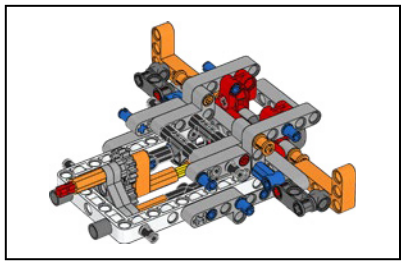

73

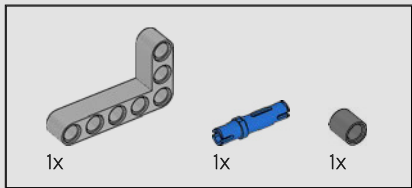
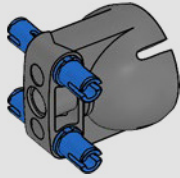

74

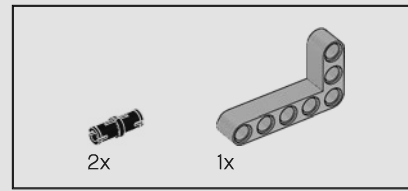
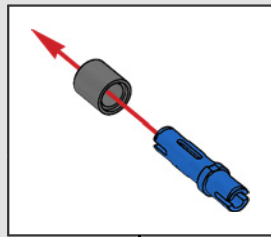
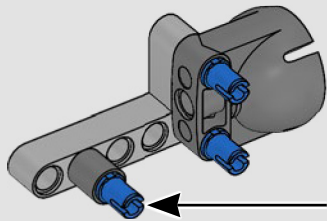

75

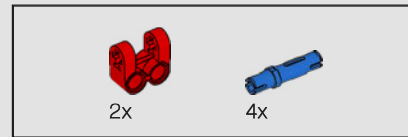
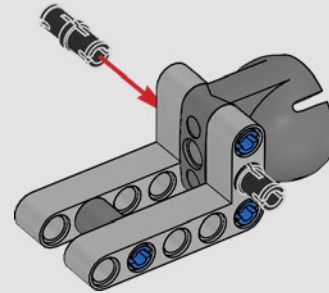

76

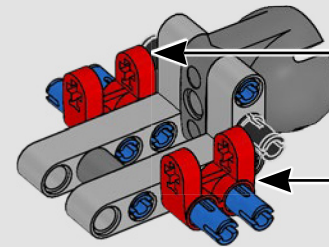
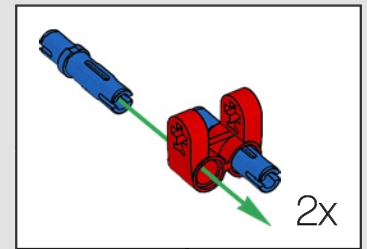

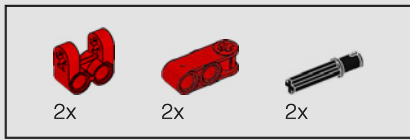

77

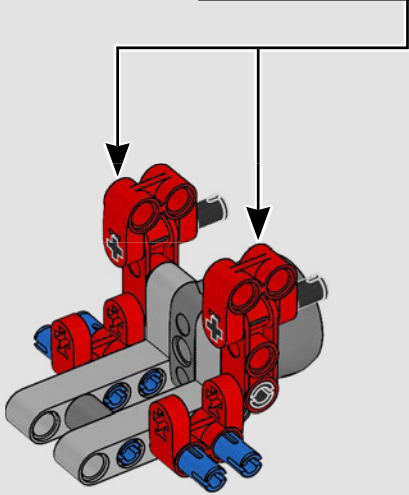
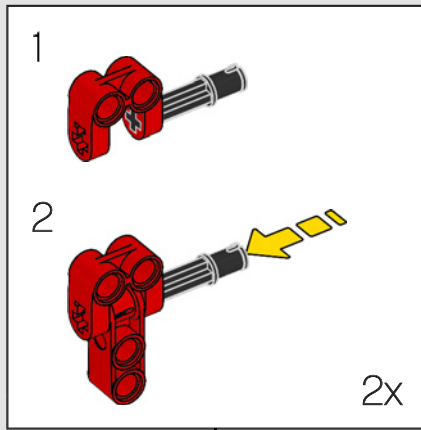

78

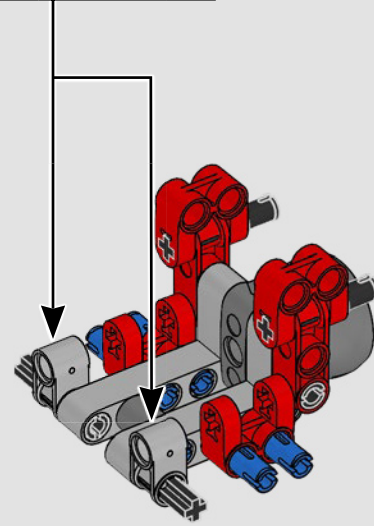
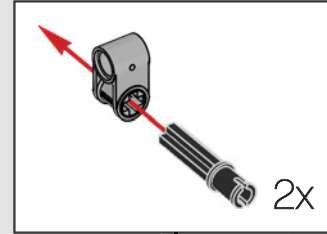

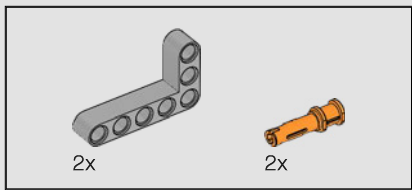

79

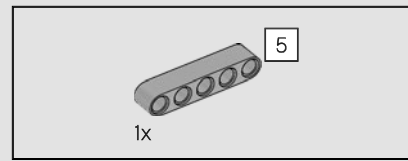
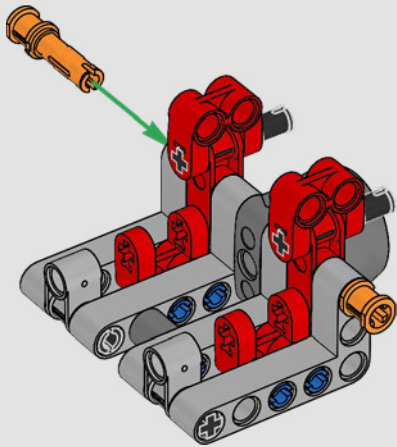

80

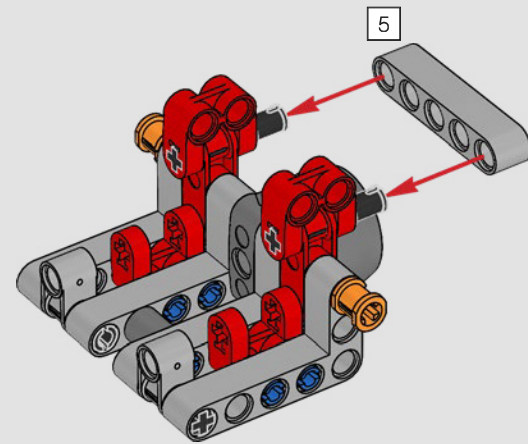



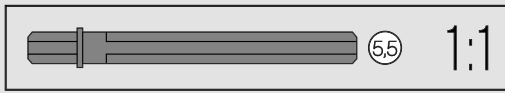
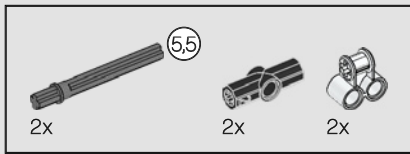

81

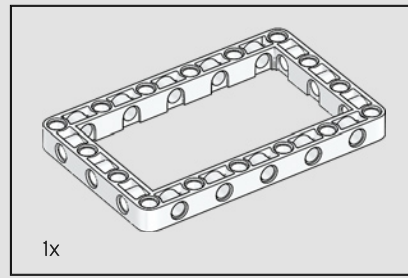
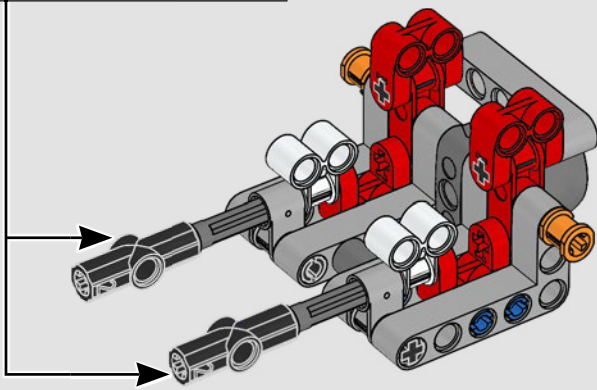
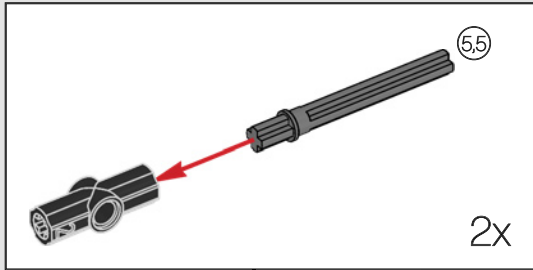

82

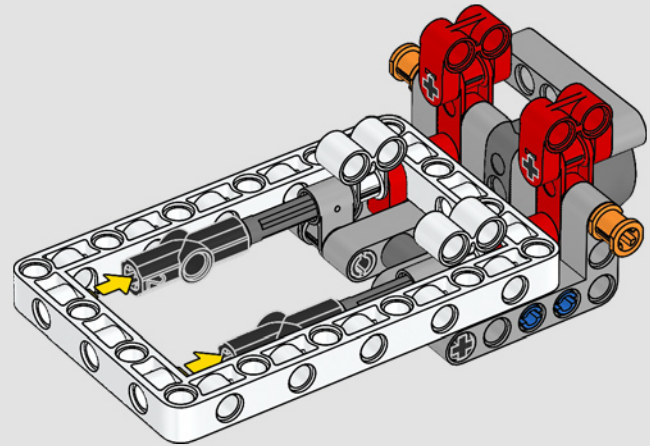

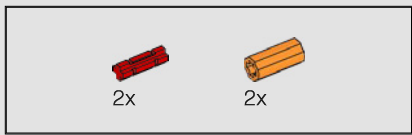

83

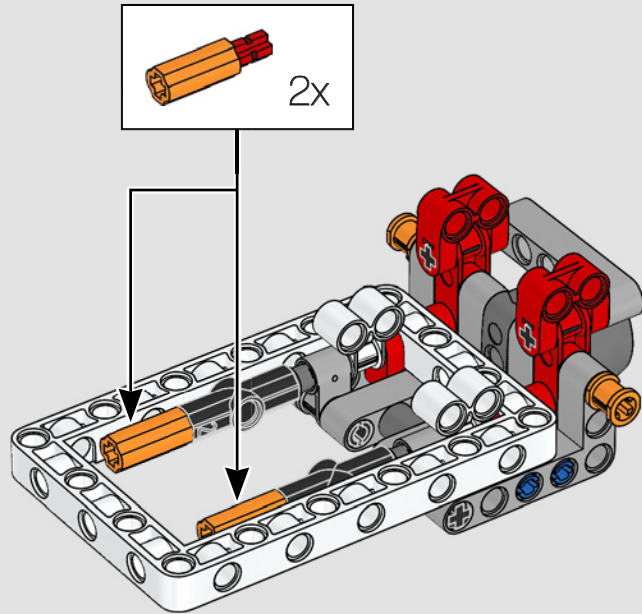

84

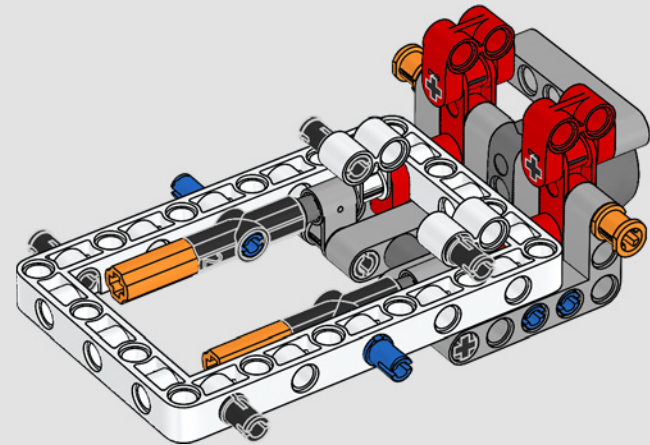

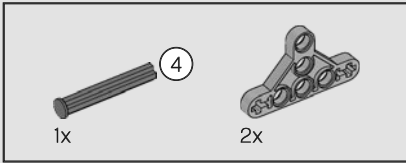
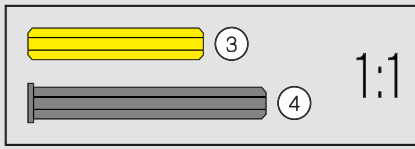
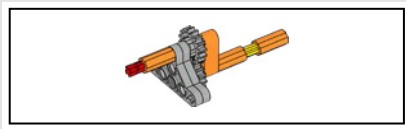

85

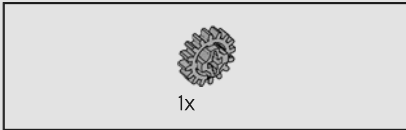
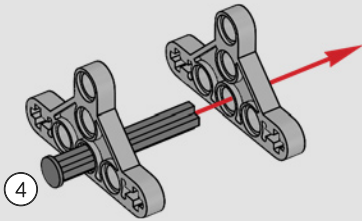

86

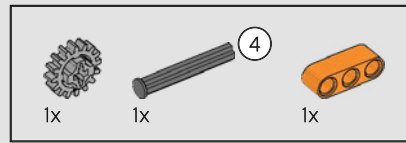
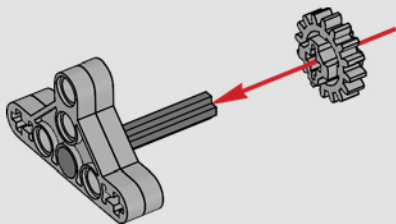

87

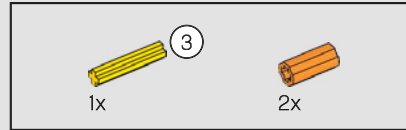
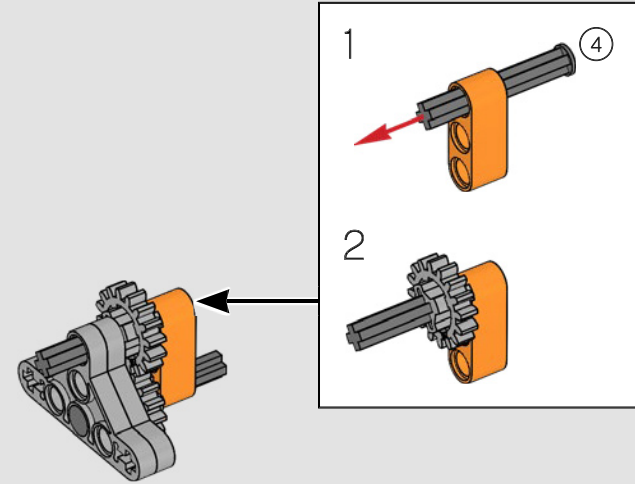

88

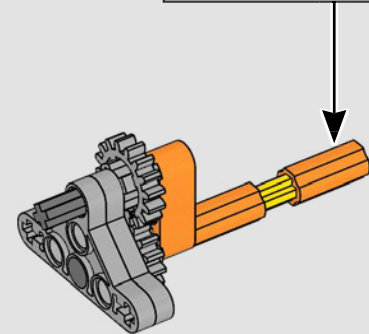
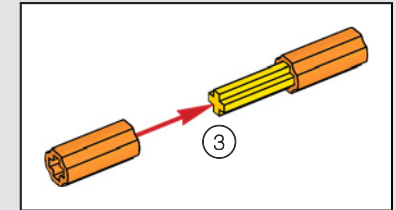

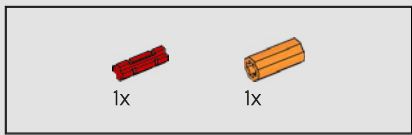

89

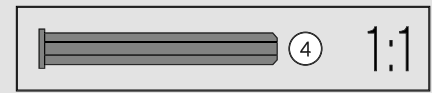
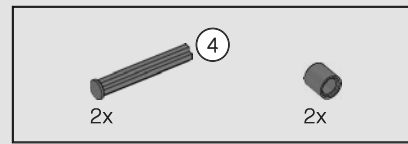
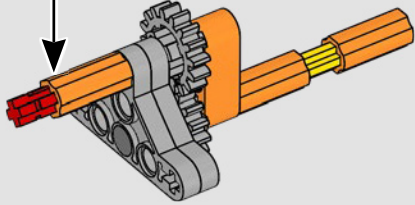
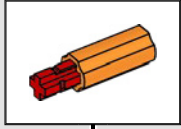

91

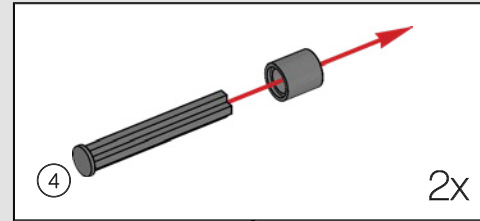

90

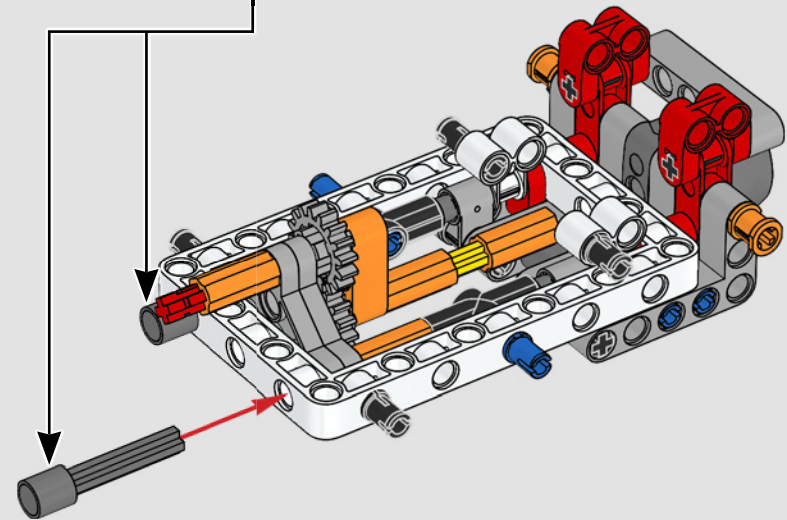
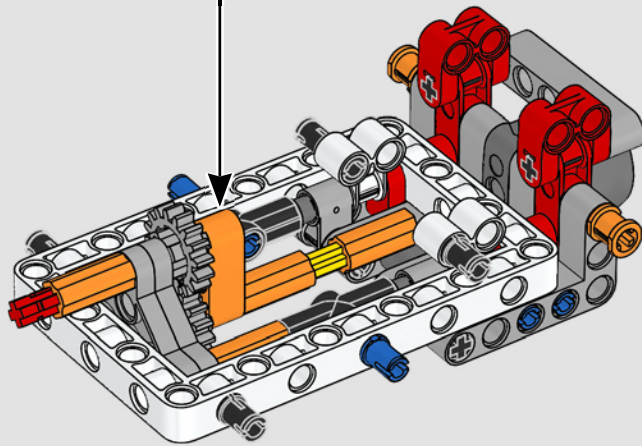

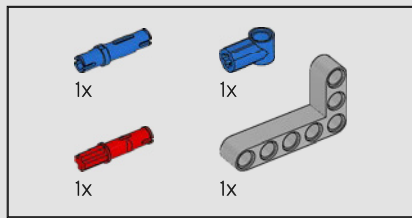

92

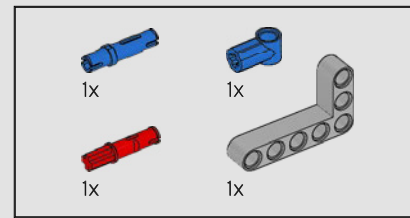
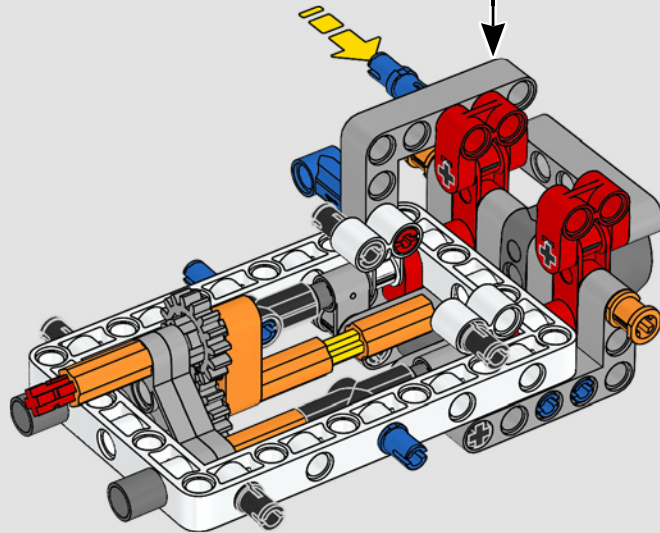
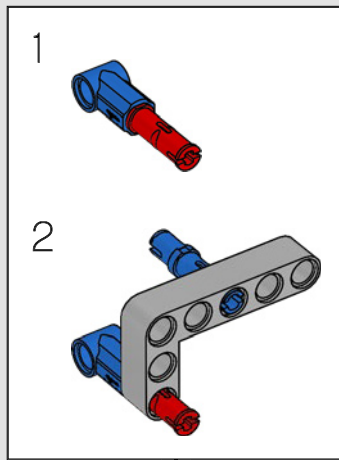

93

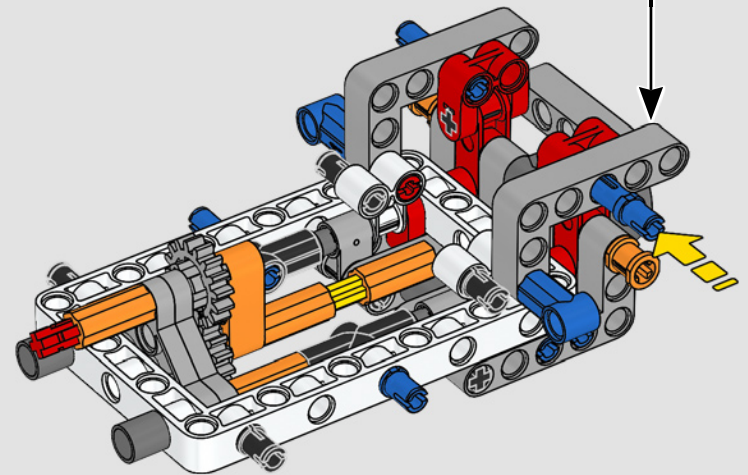
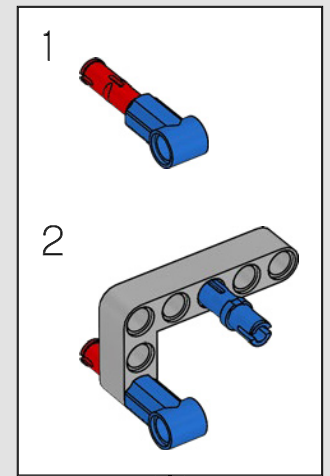

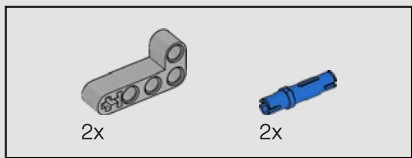

94

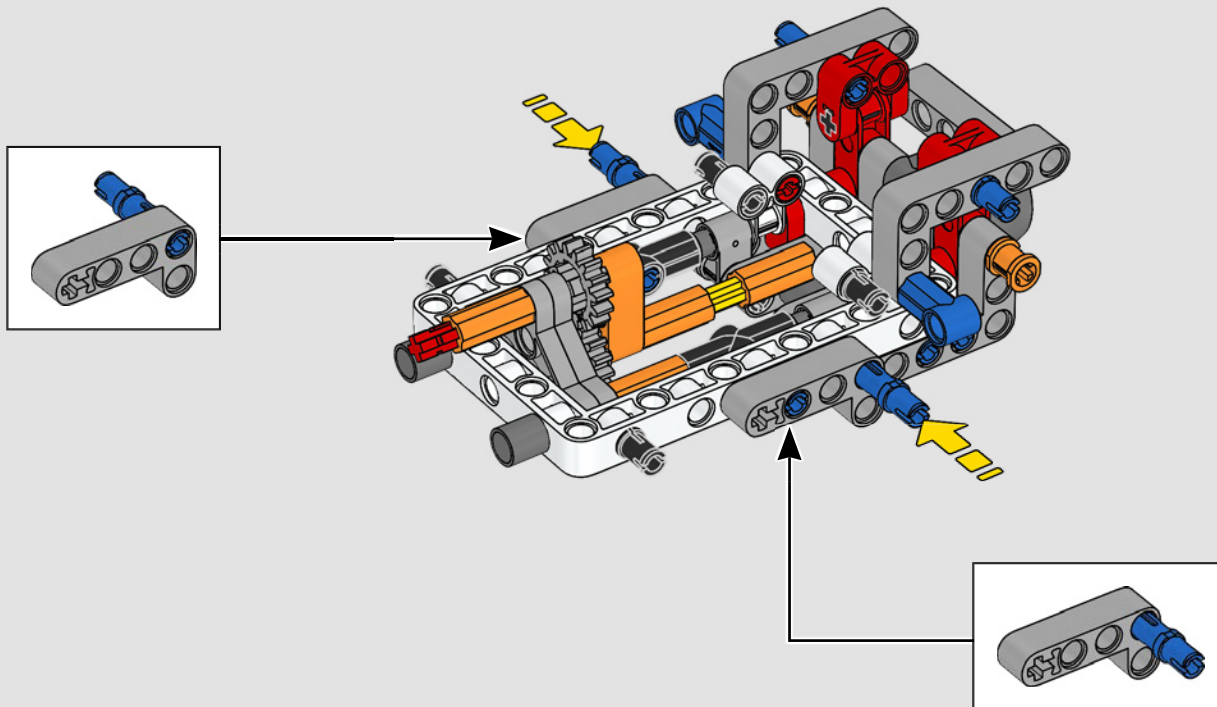

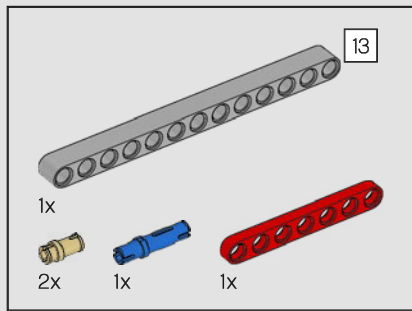

95

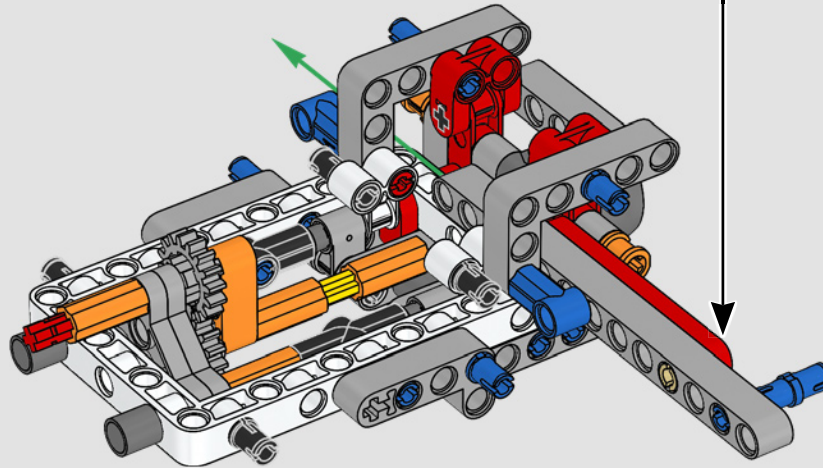
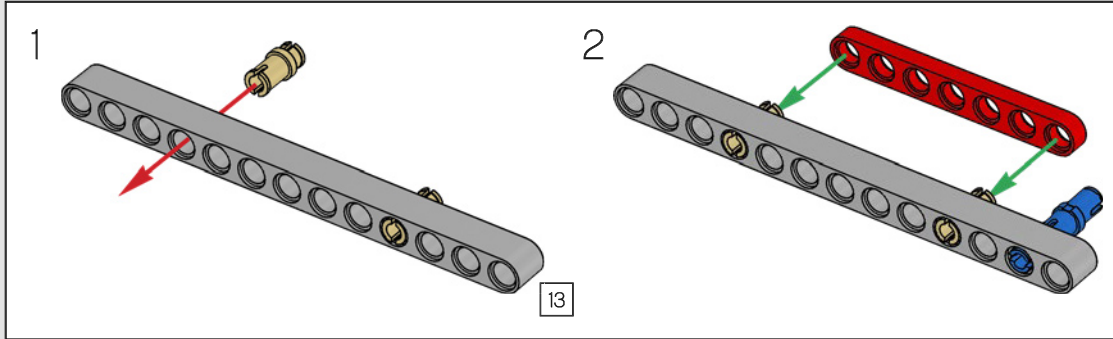
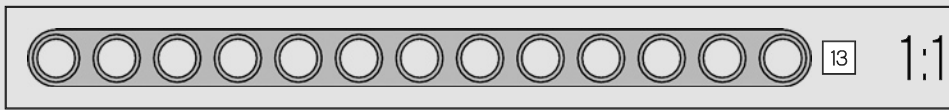

96

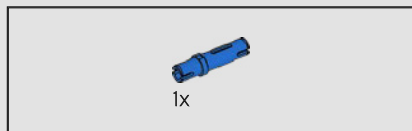
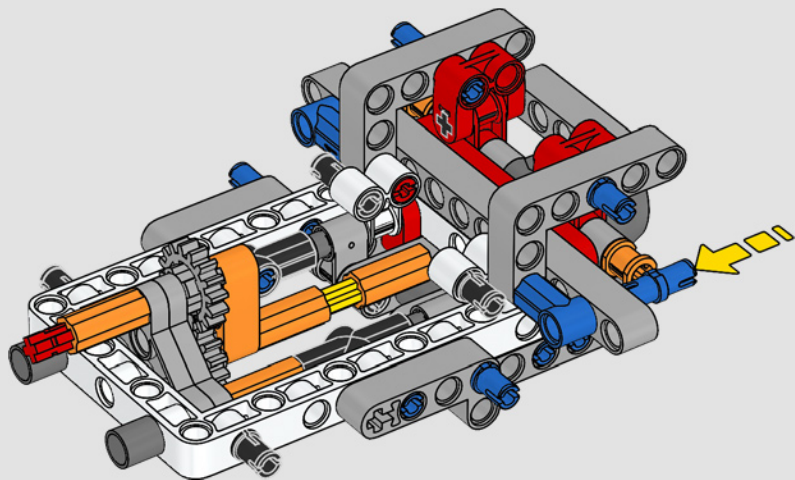

97

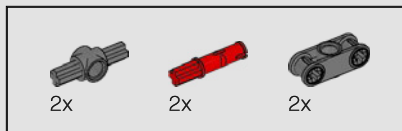
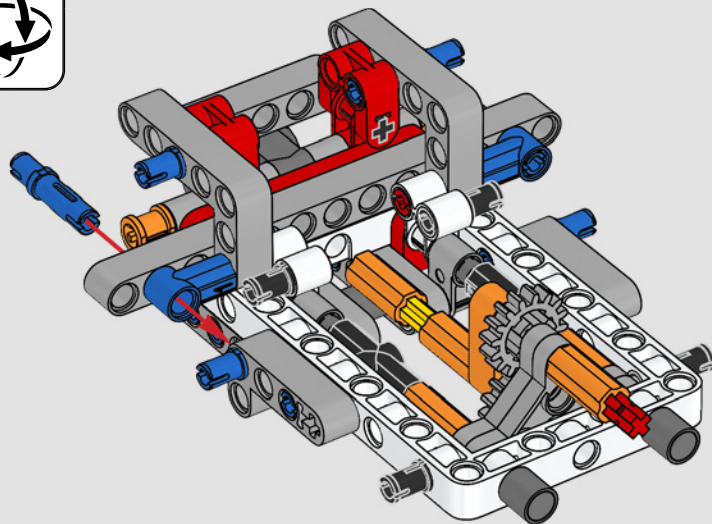

98

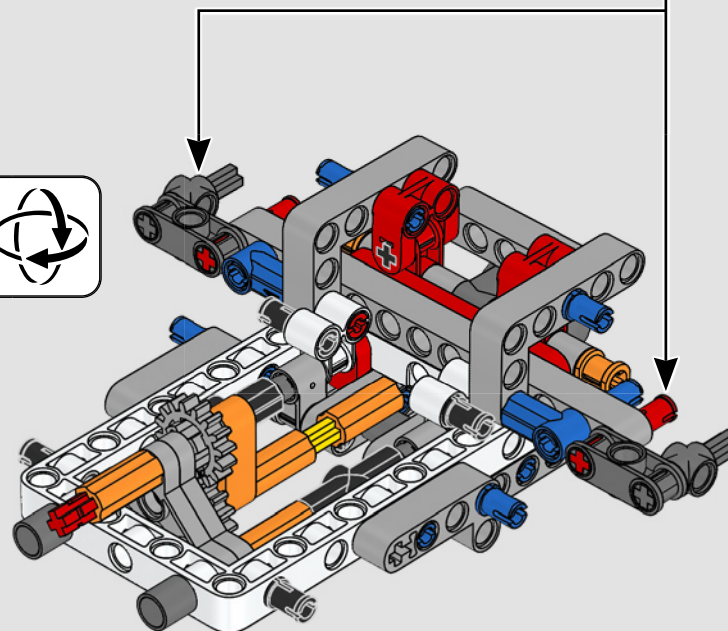
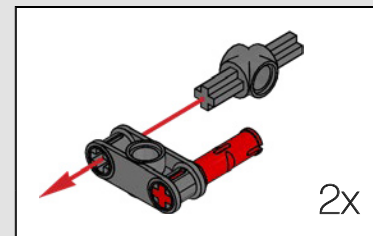



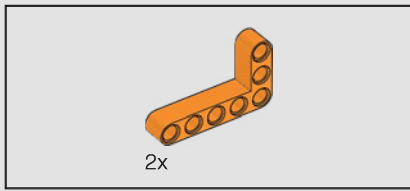

99

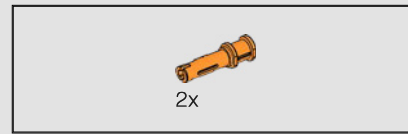
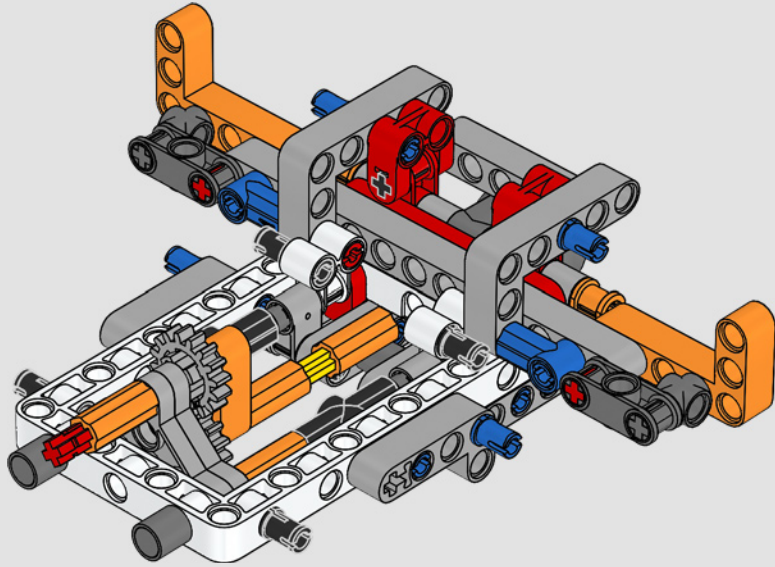

100

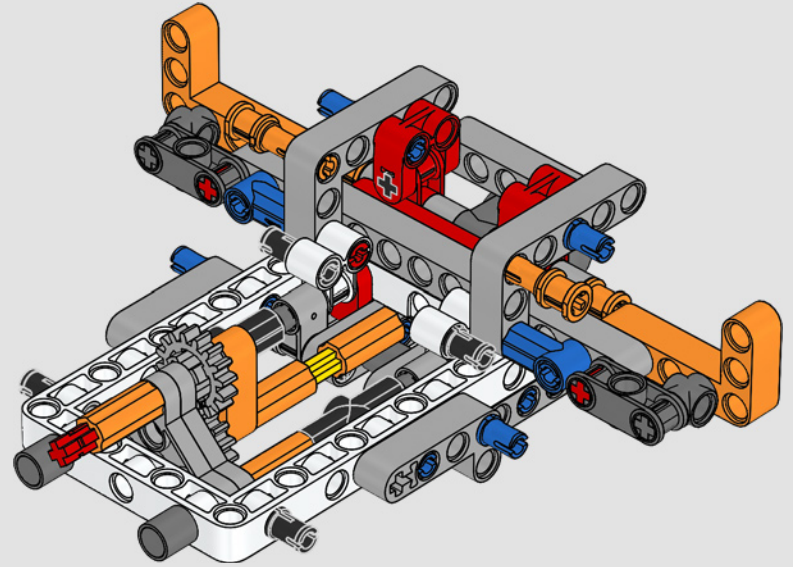

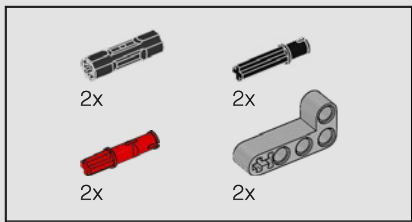

101

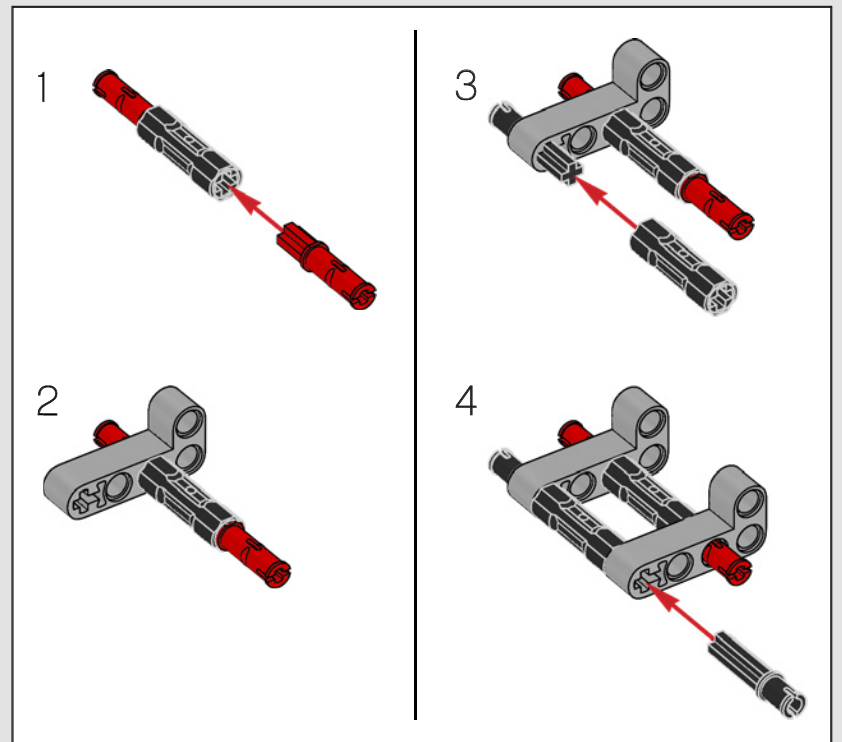
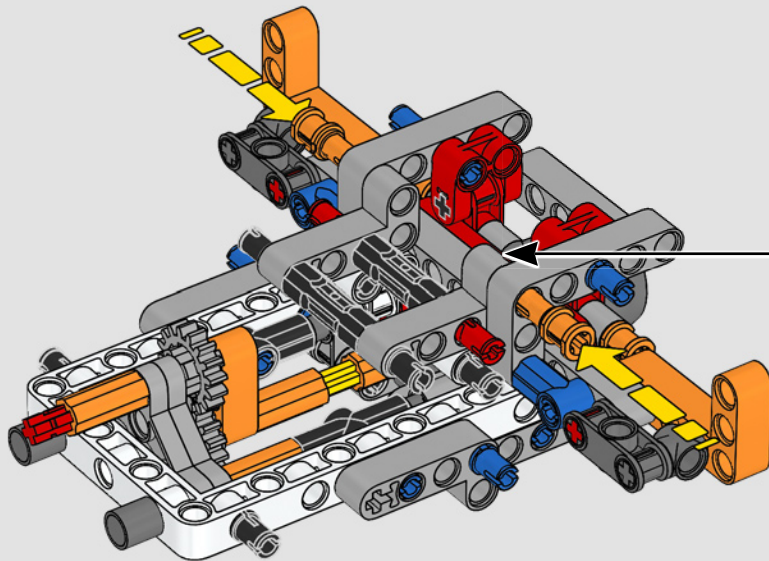

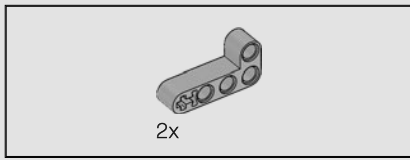

102

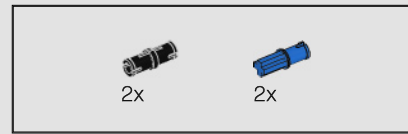
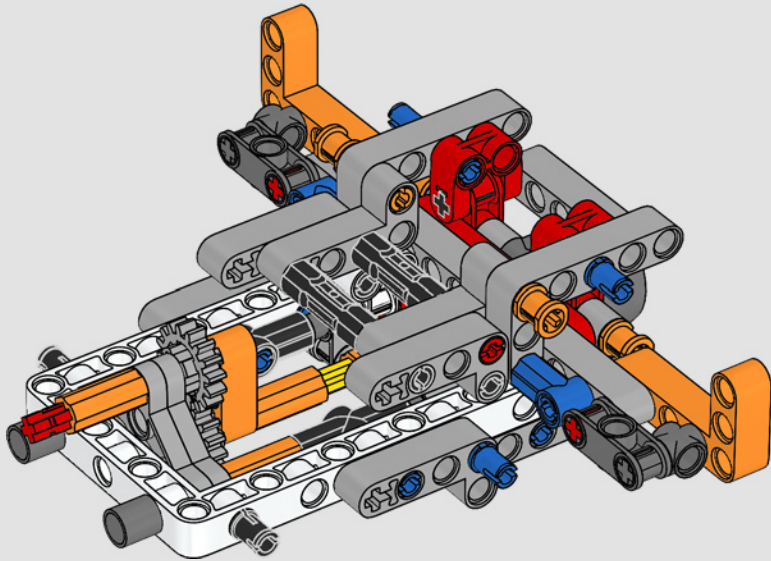

103

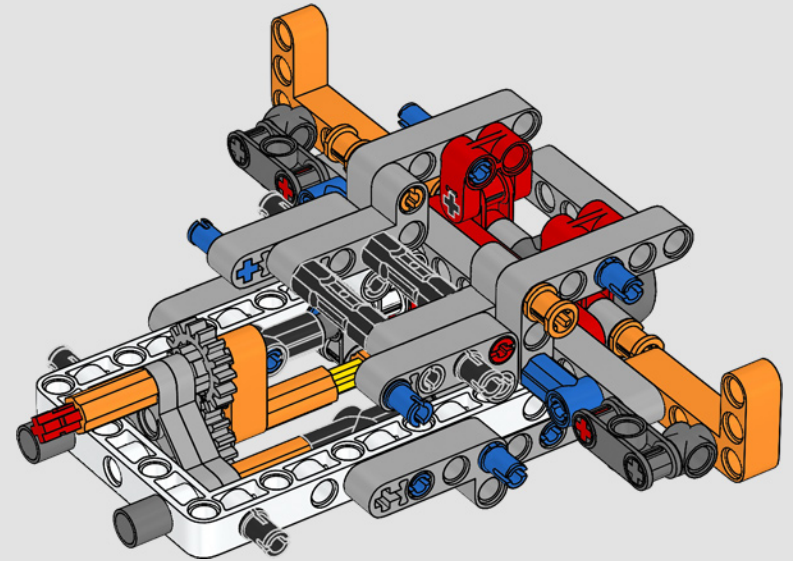

104

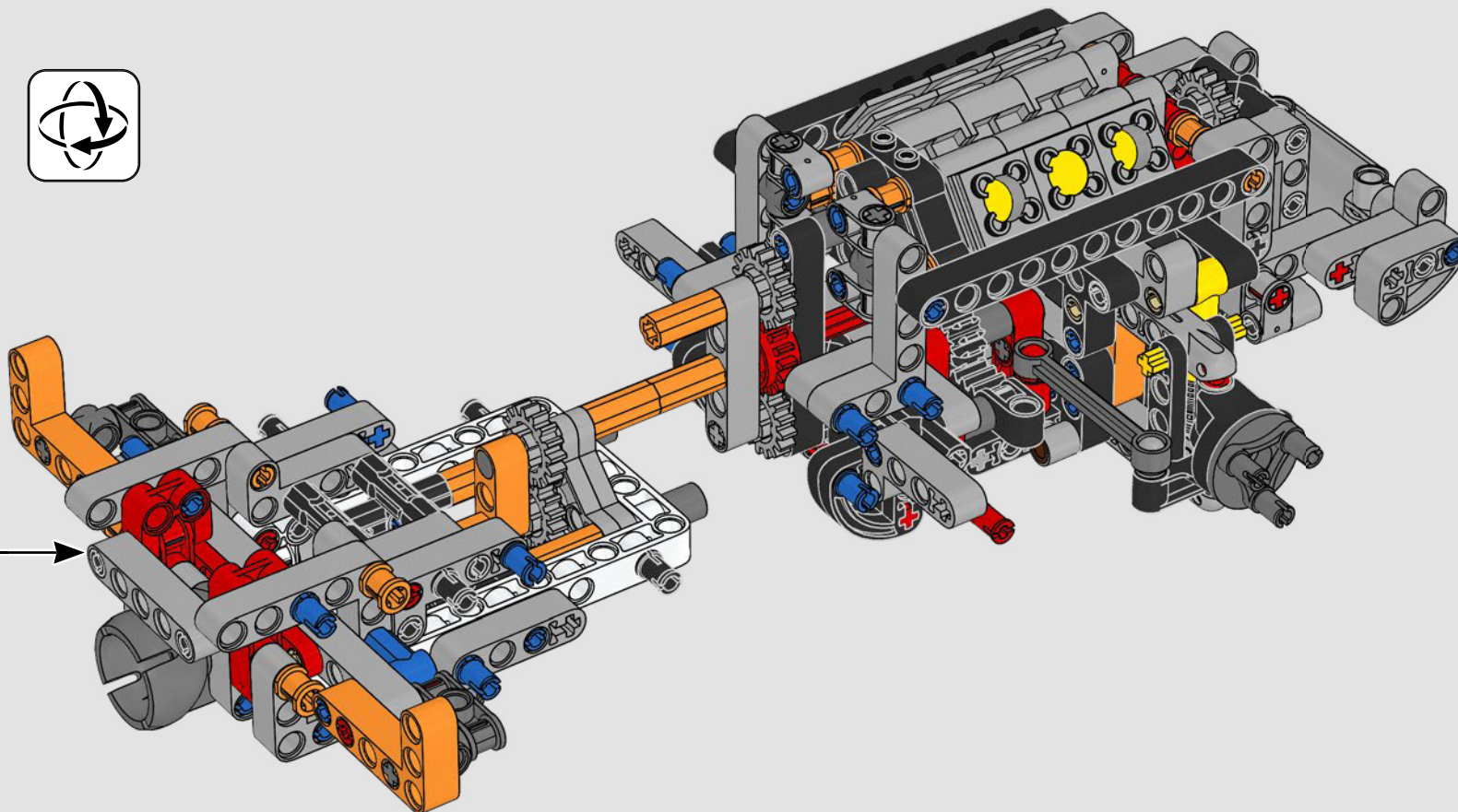

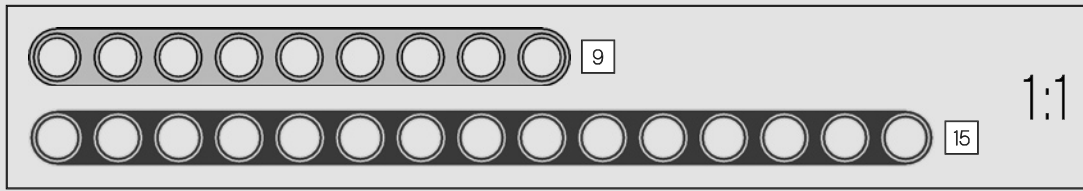
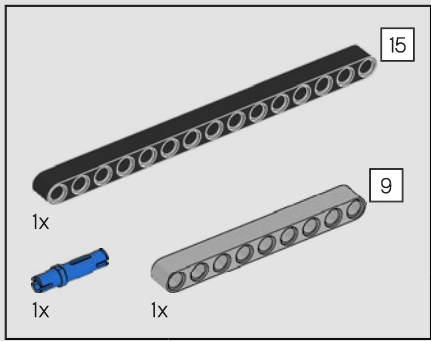

105

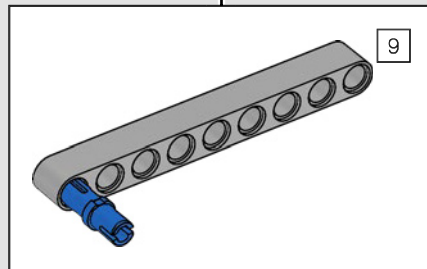
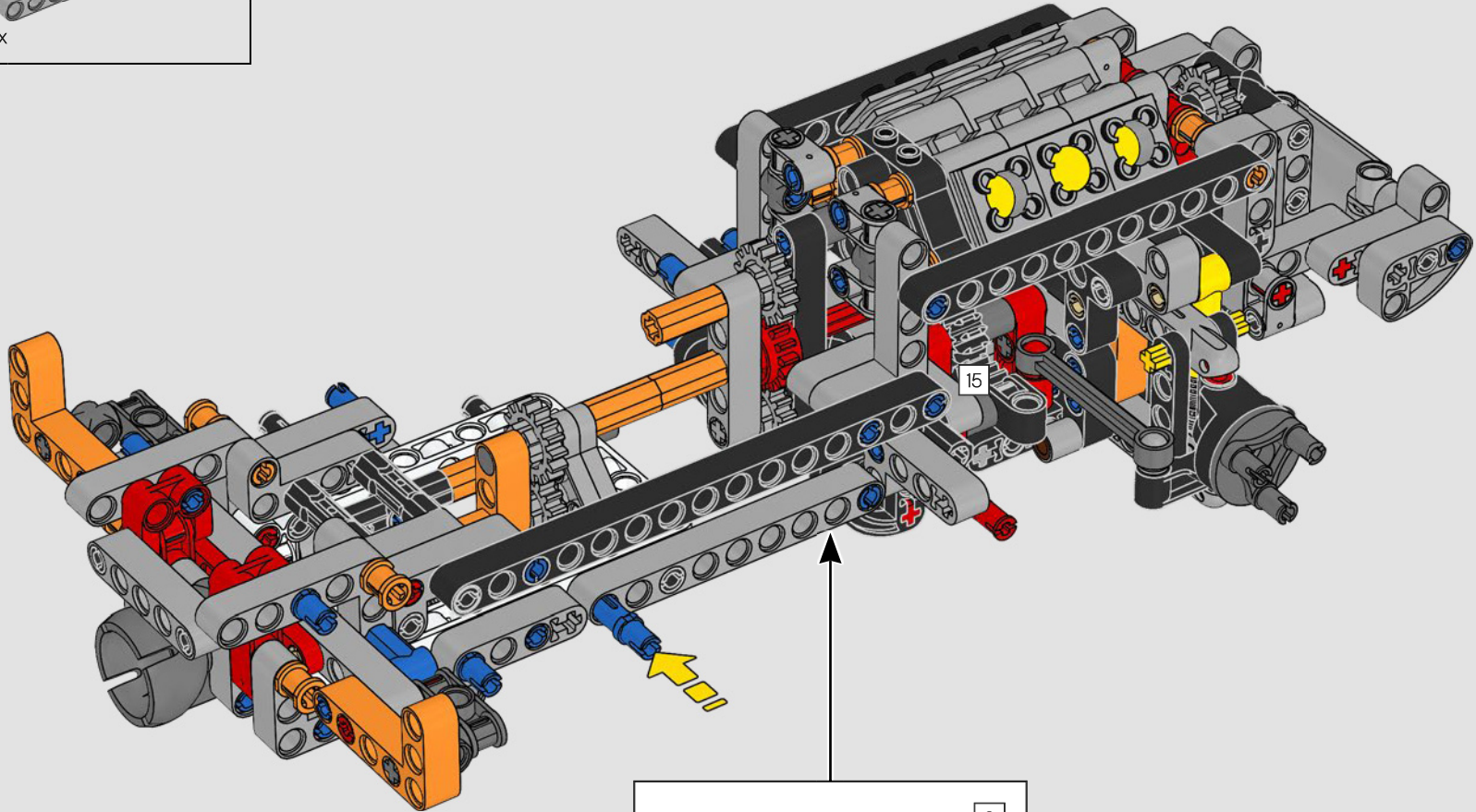

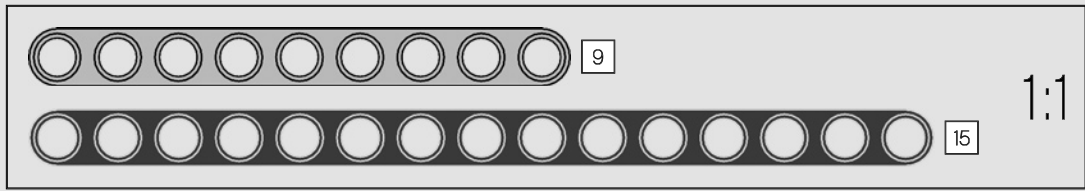
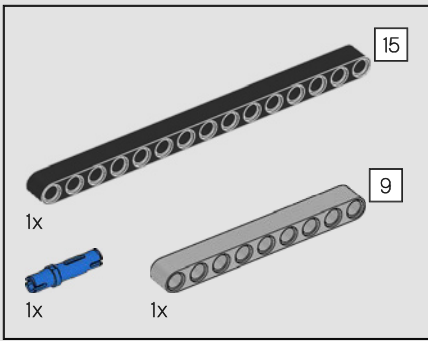

106

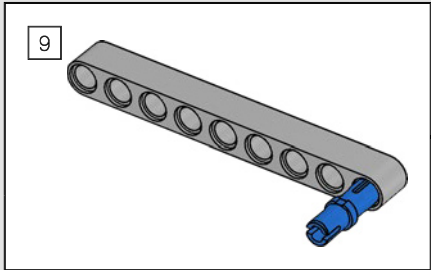
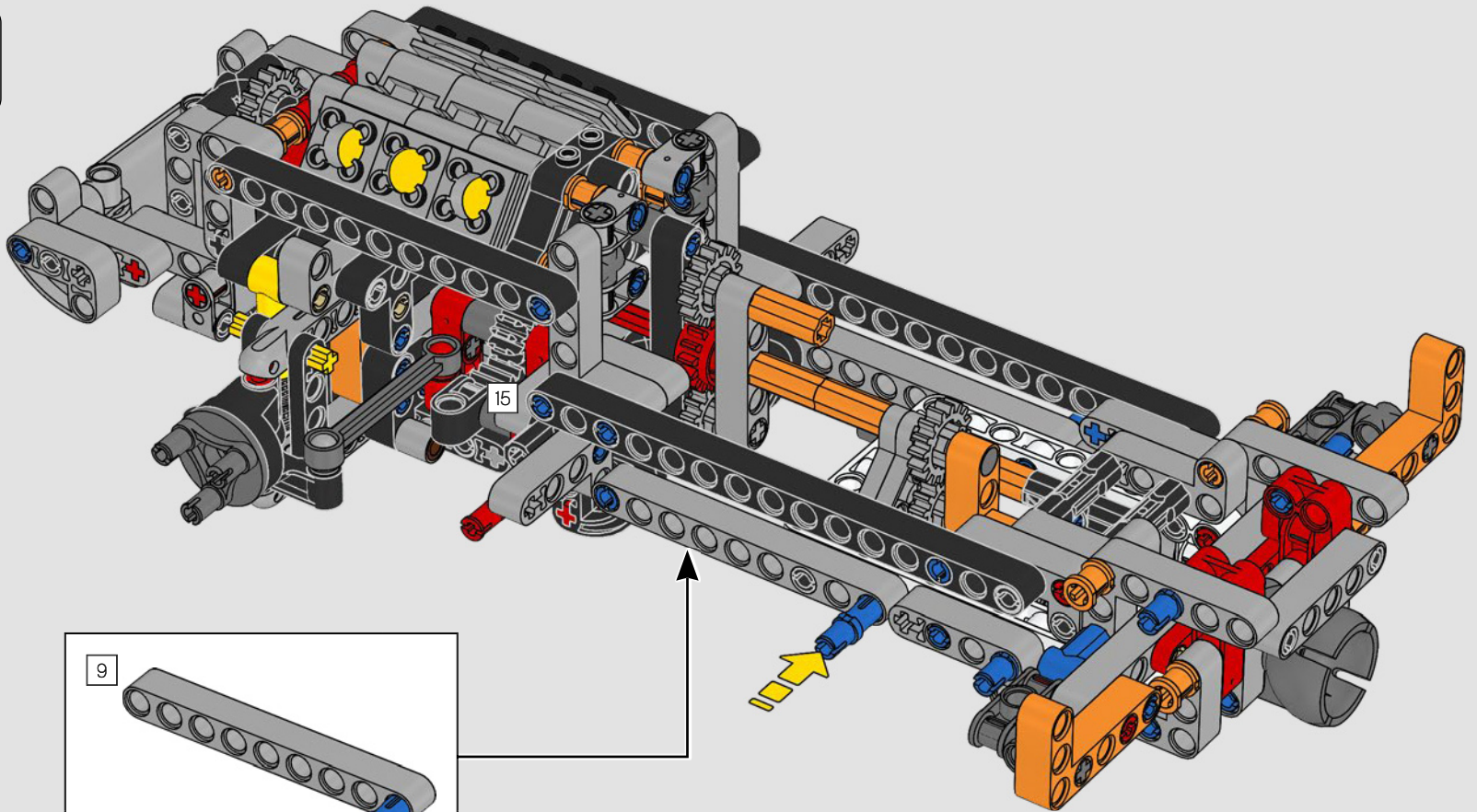

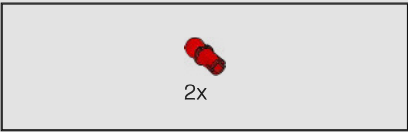
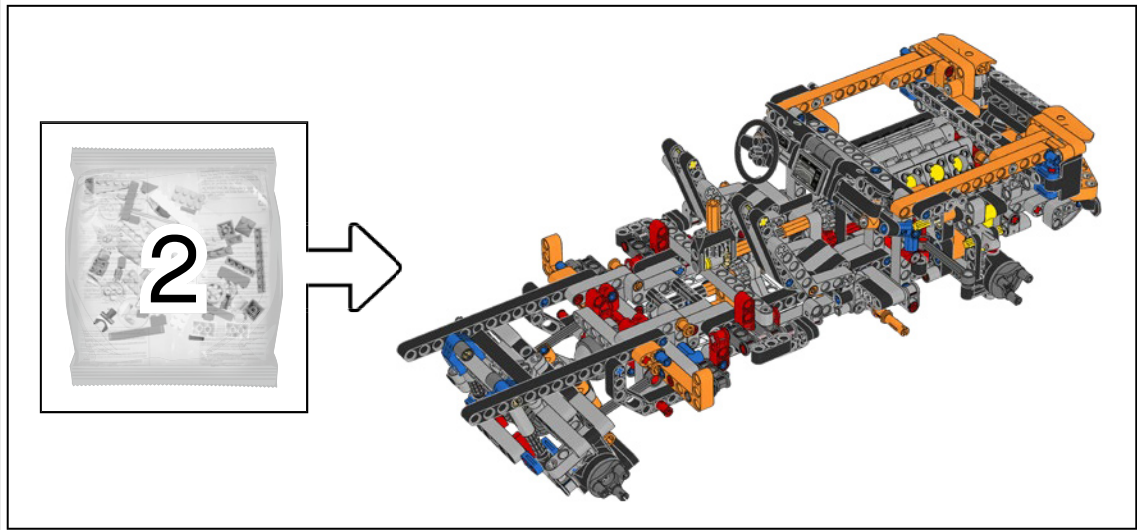

107

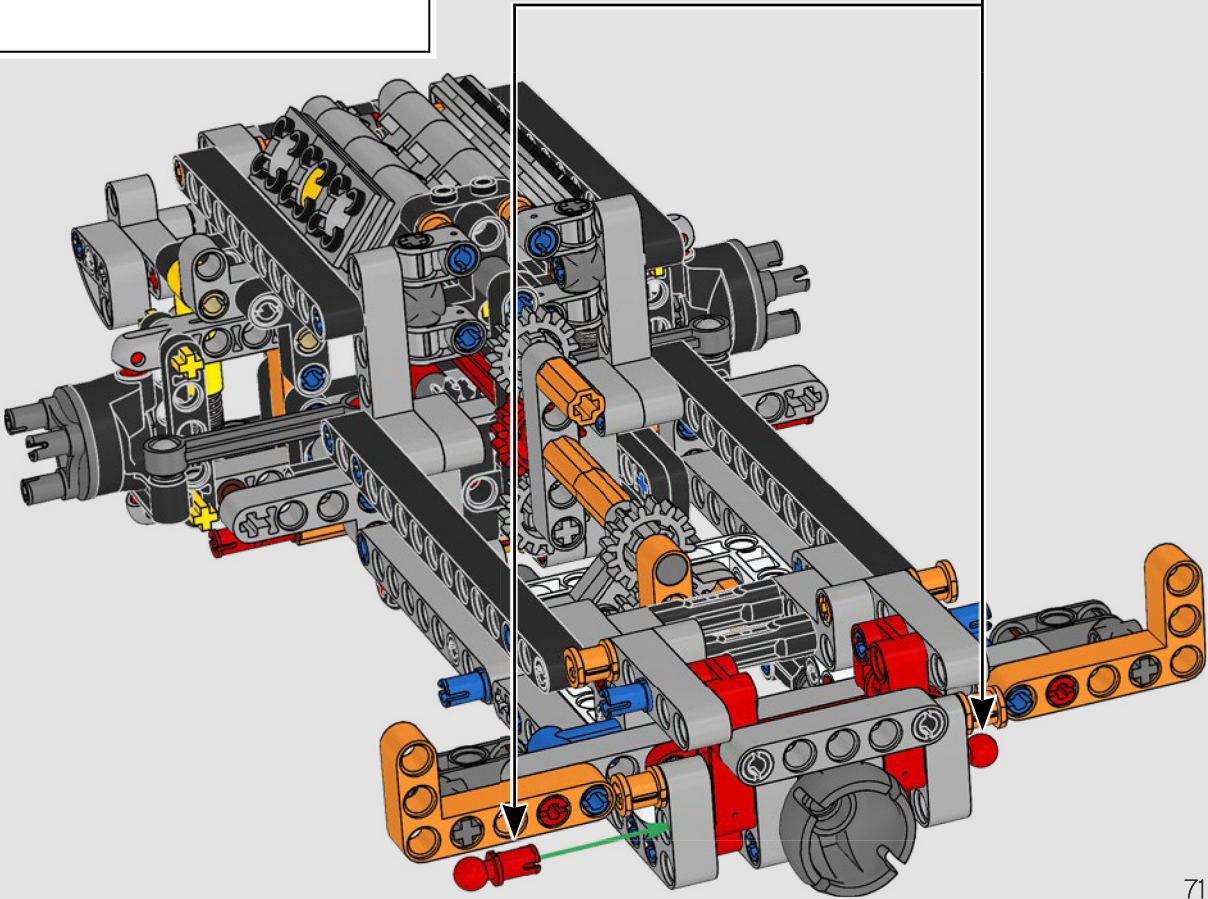

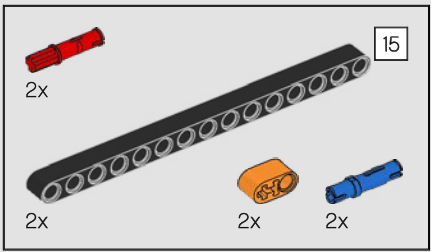

108

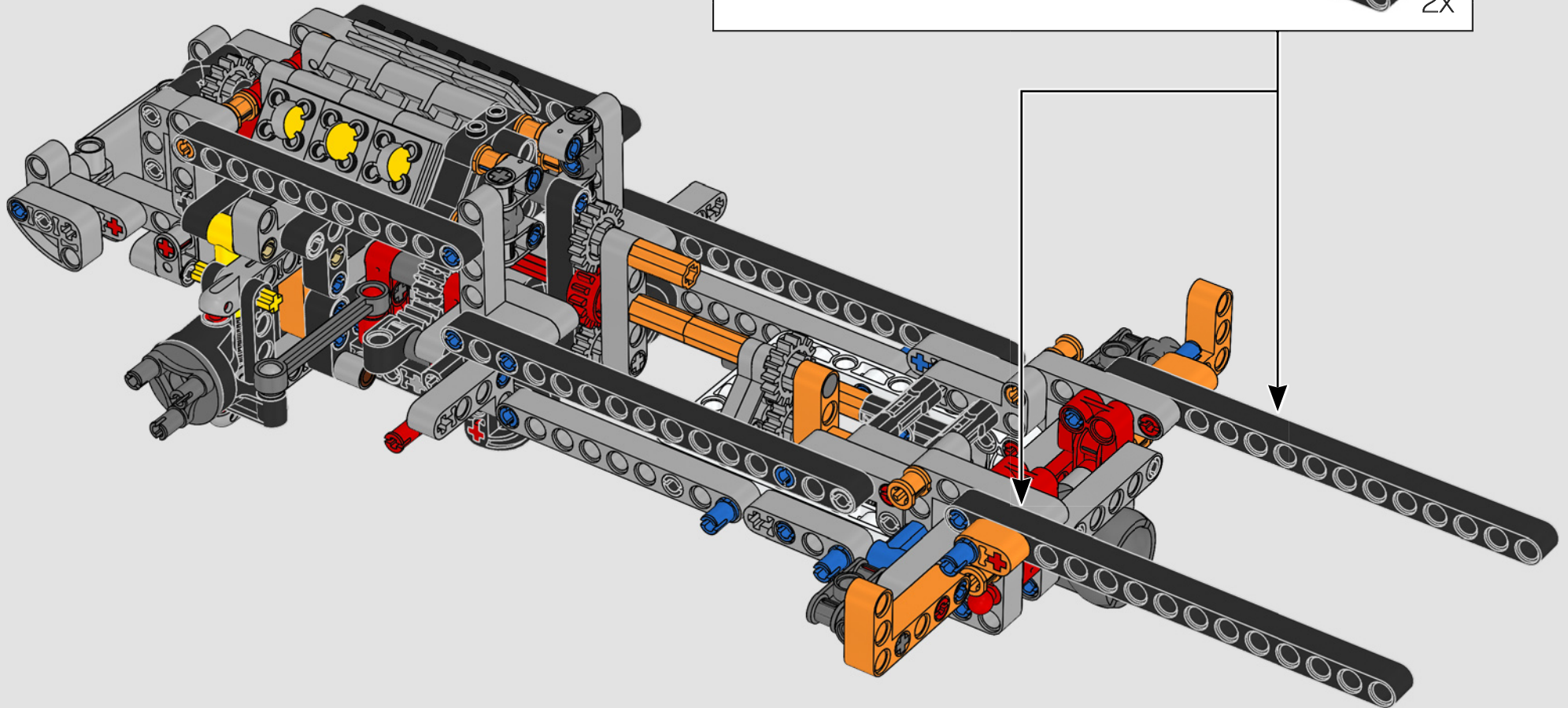
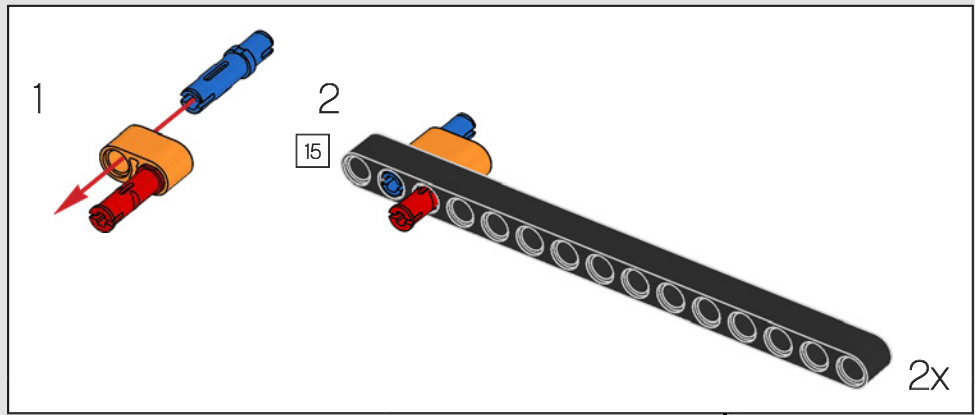



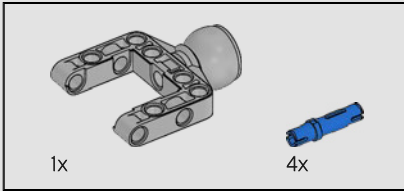
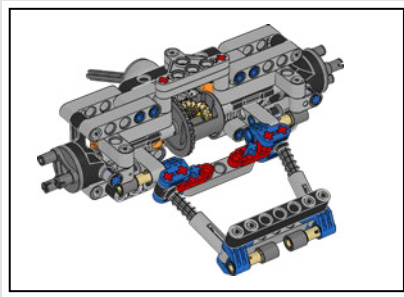

109

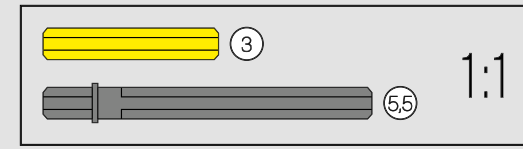
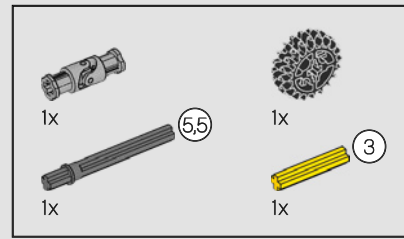
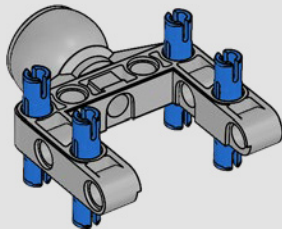

110

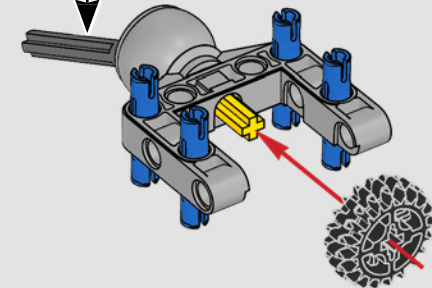
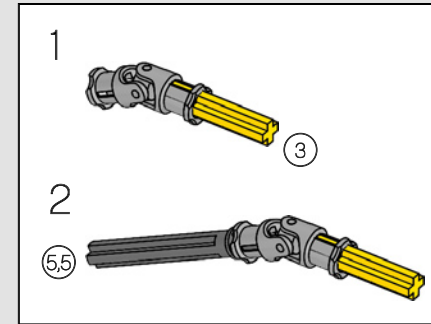

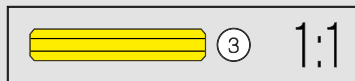
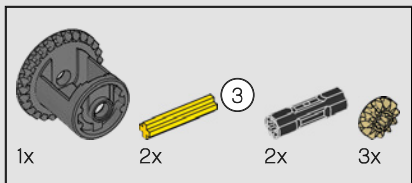

111

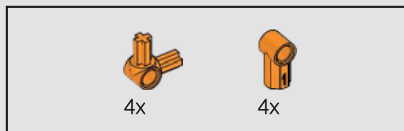
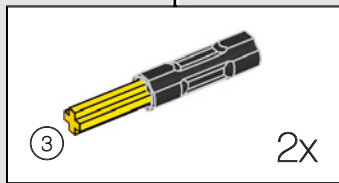
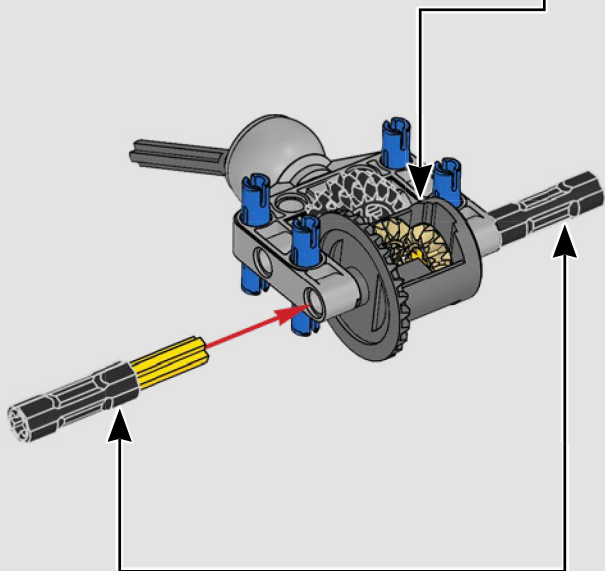
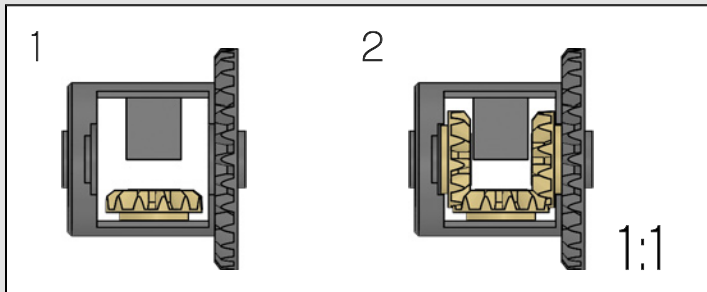

112

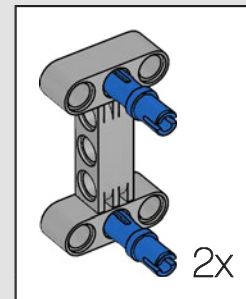
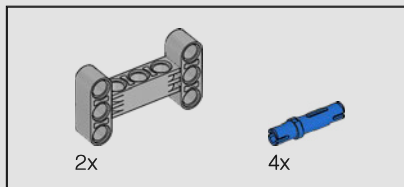
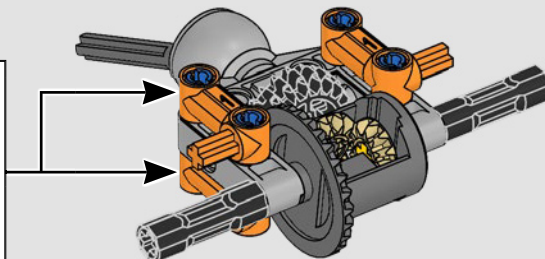
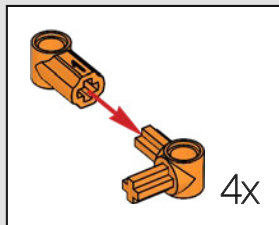

113

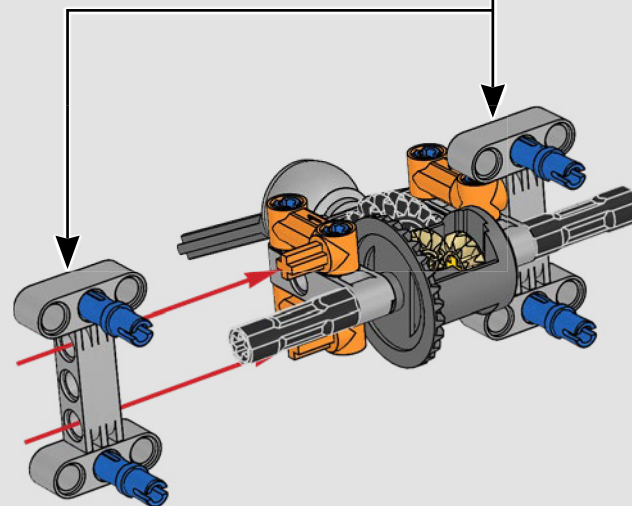

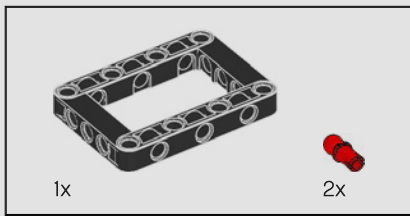

114

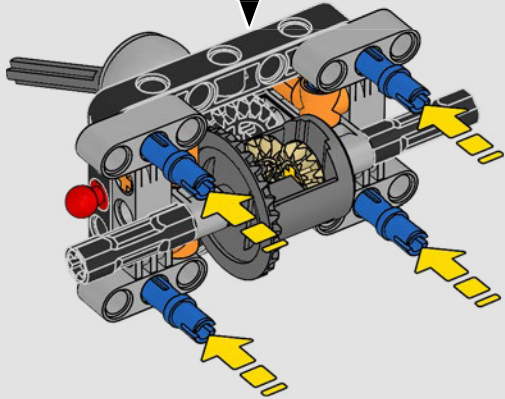
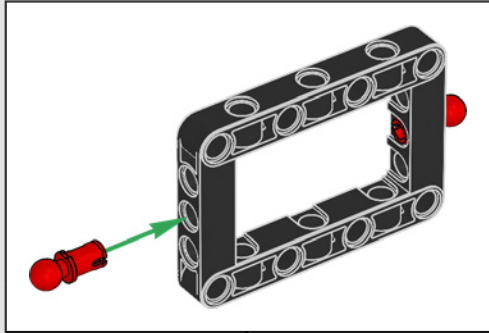

115

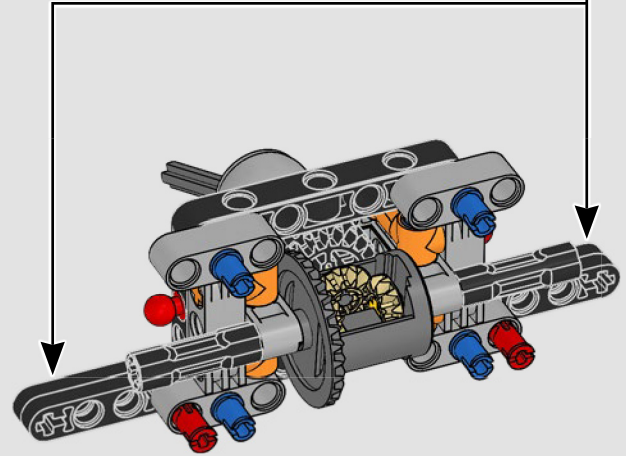
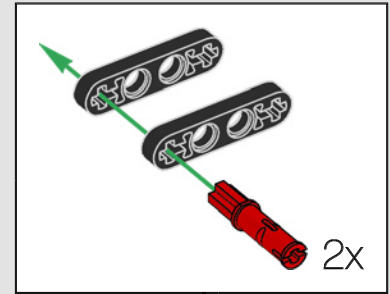

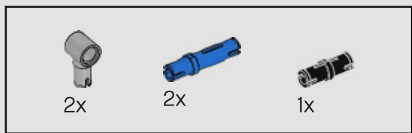

116

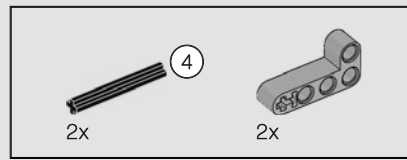
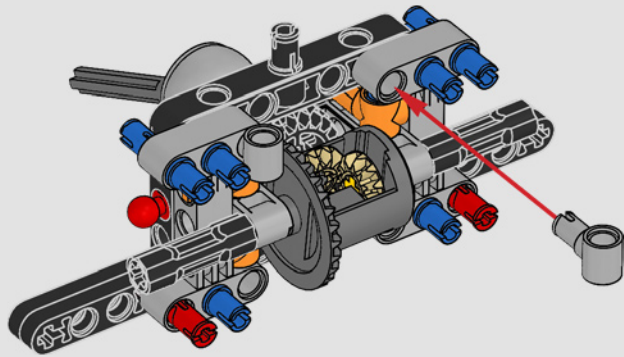

117

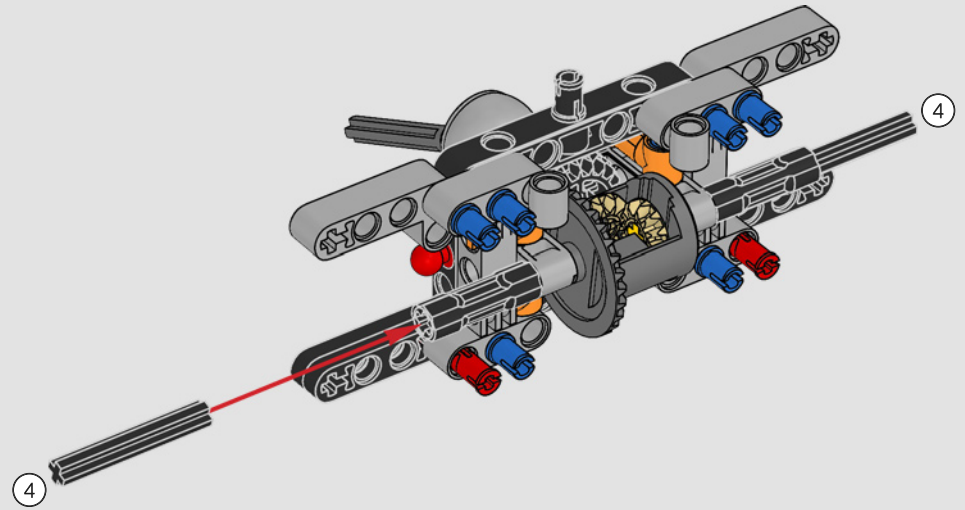
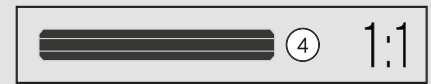

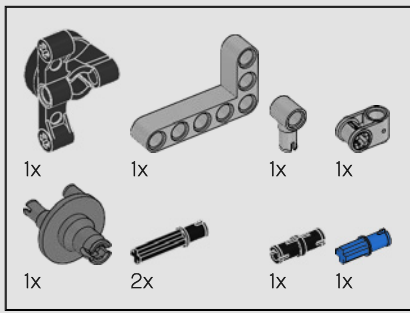

118

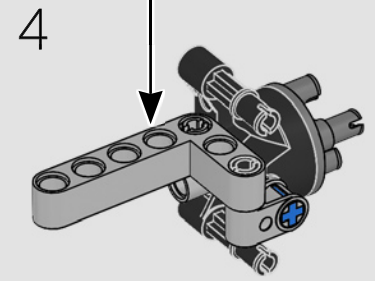
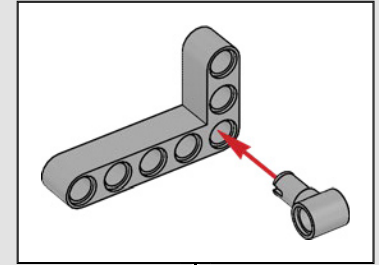
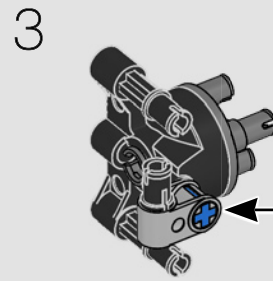
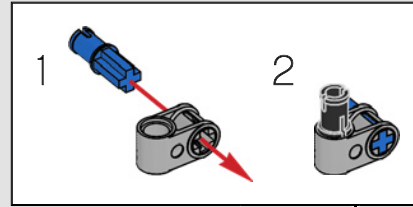
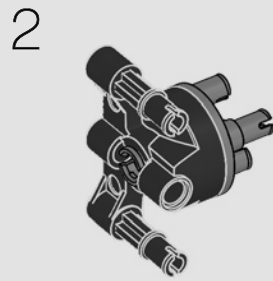
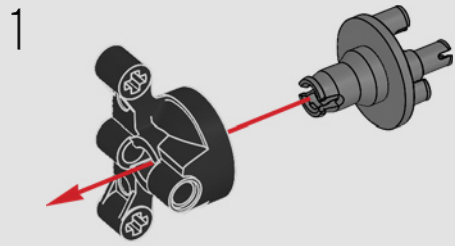

119

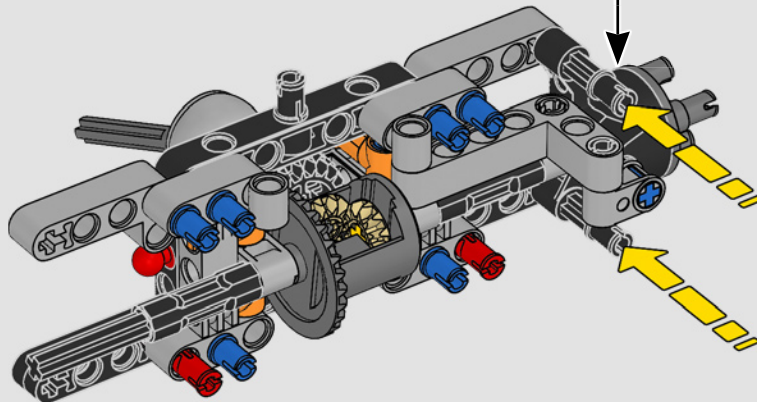

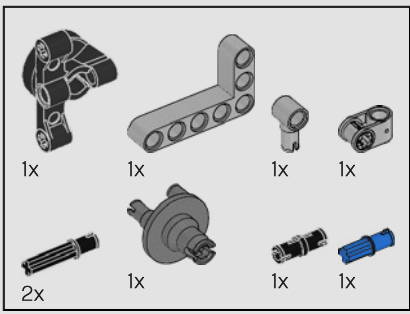

120

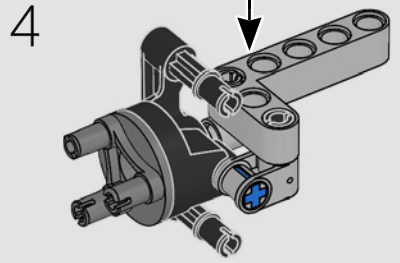
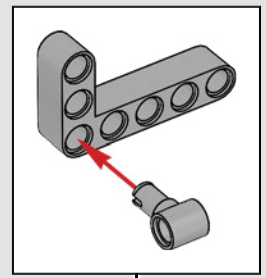
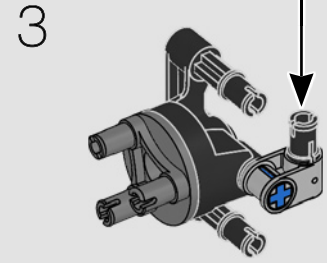
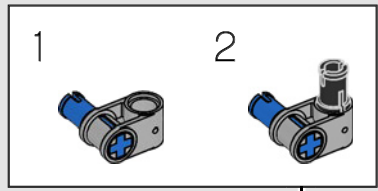
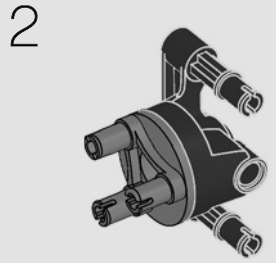
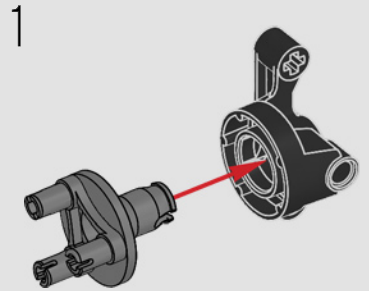

121

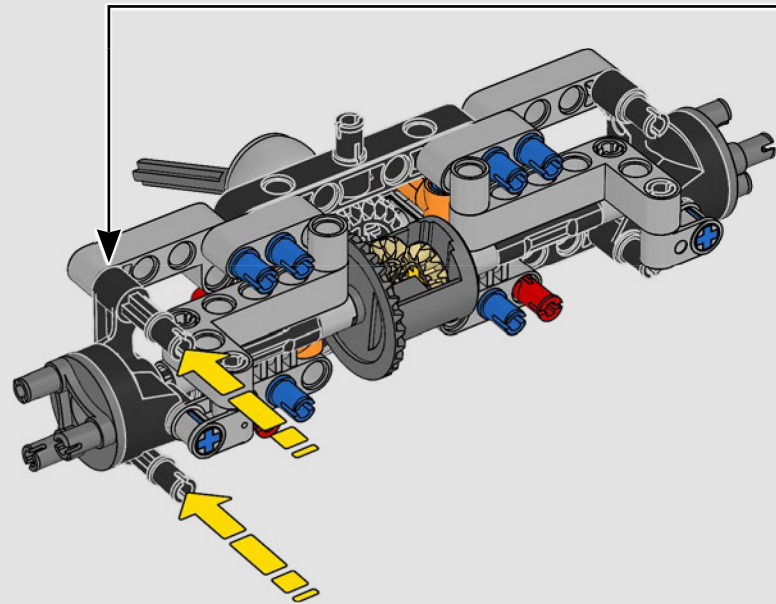

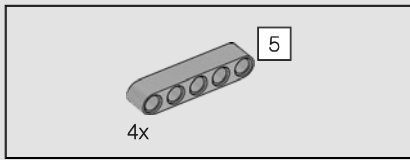

122

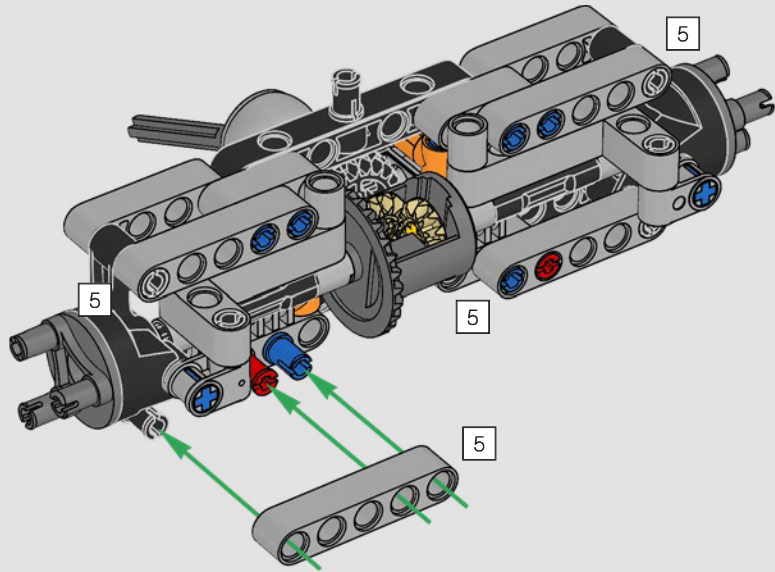

123

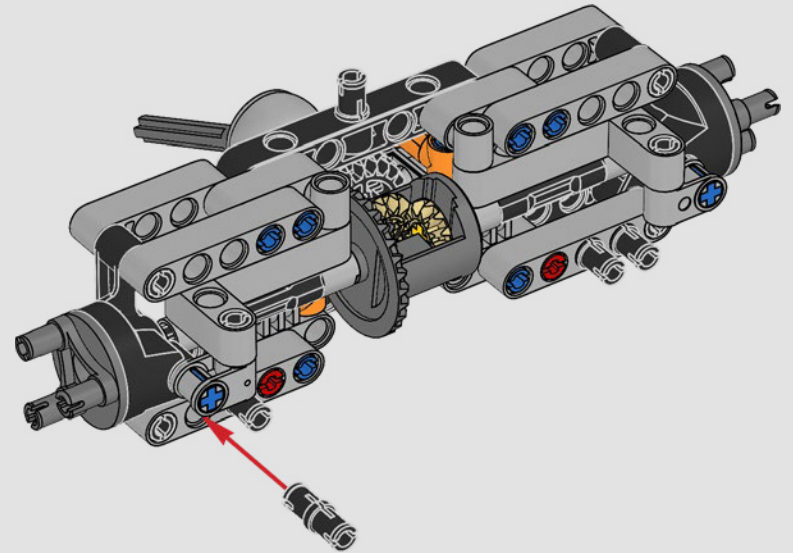

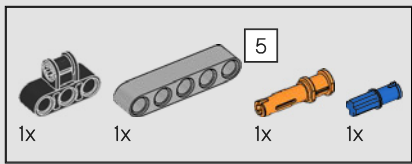

124

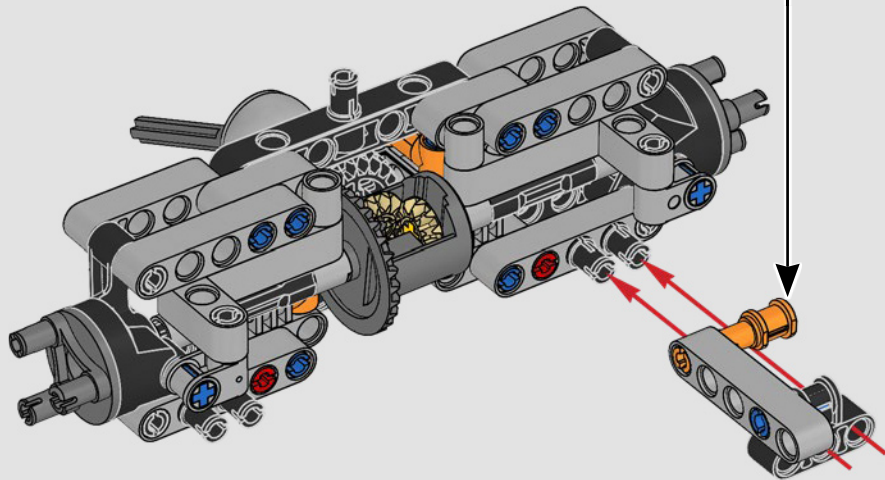
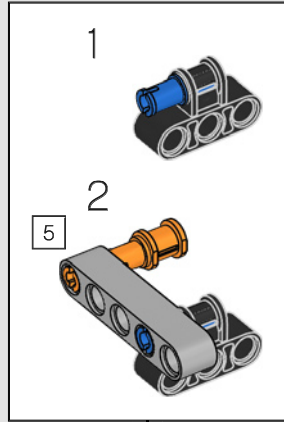

125

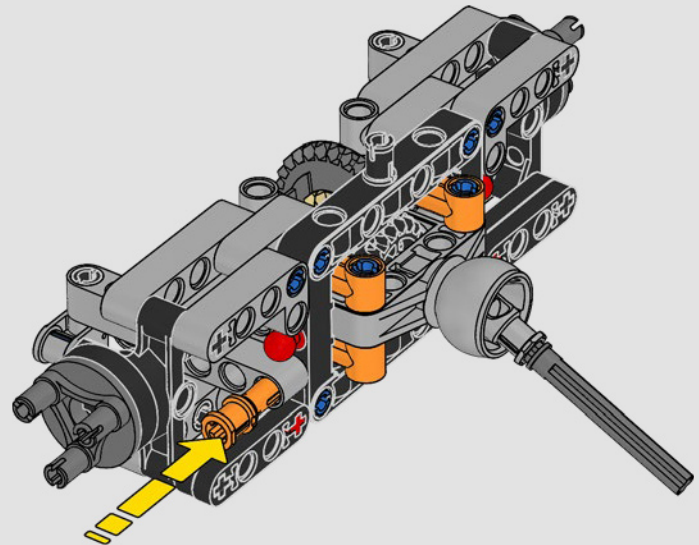
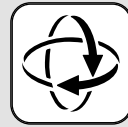



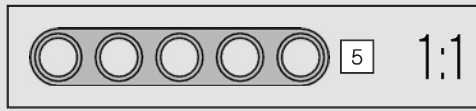
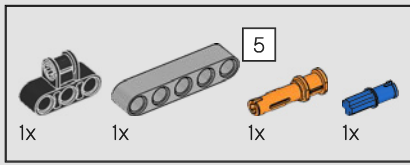

126

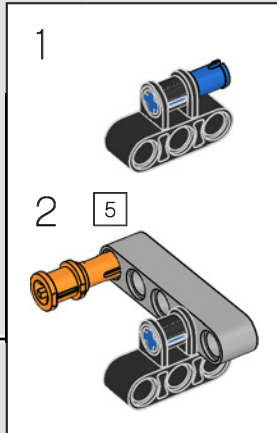
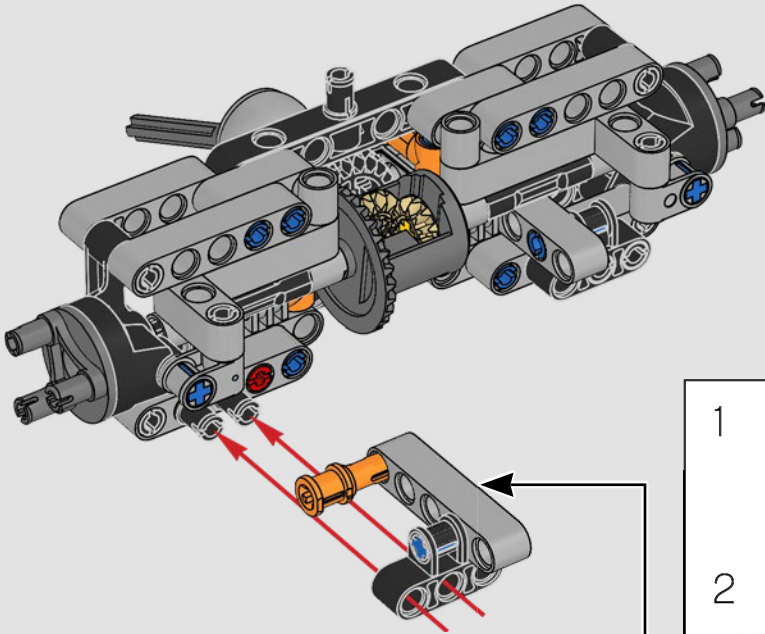

127

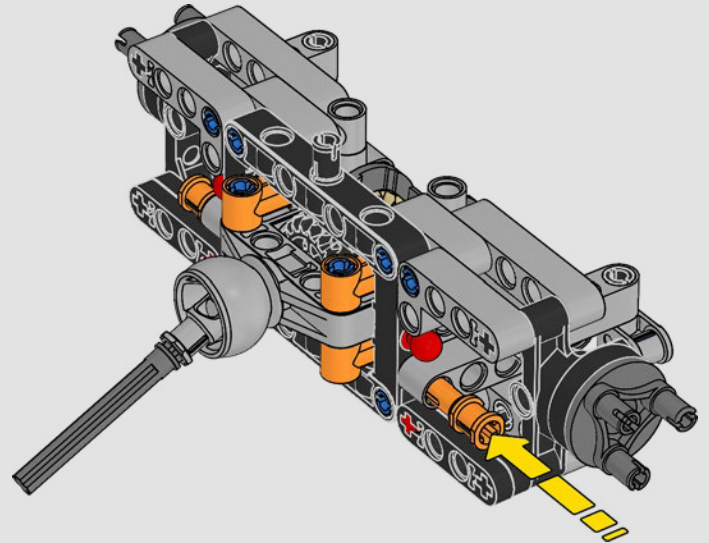
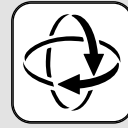

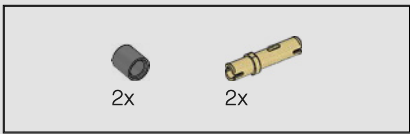

128

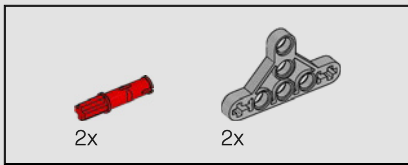
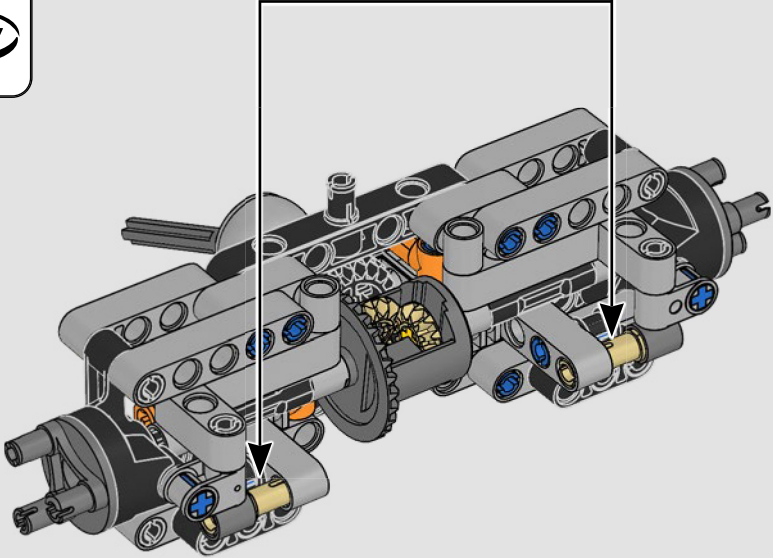
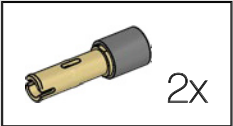

129

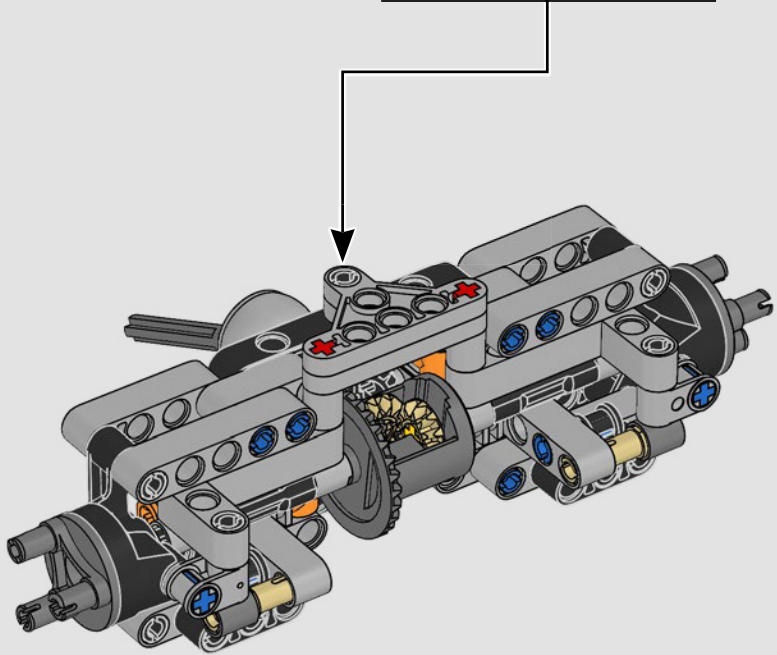
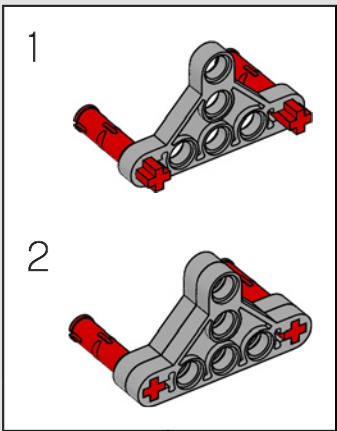

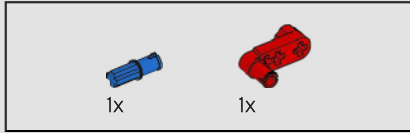
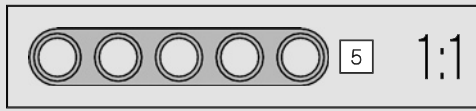
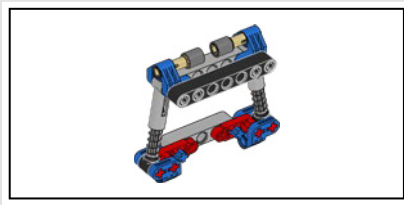

130

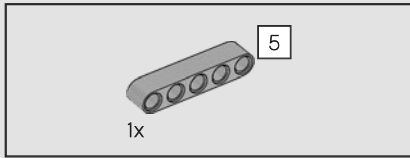
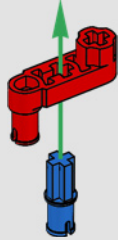

131

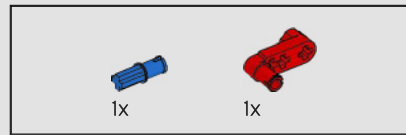
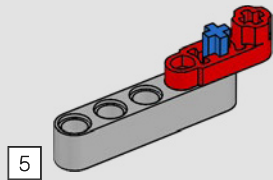

132

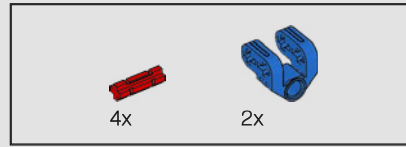
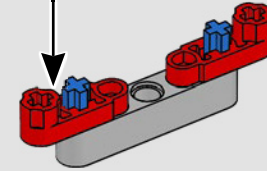
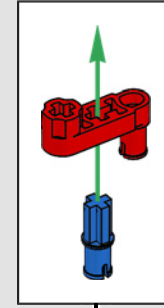

133

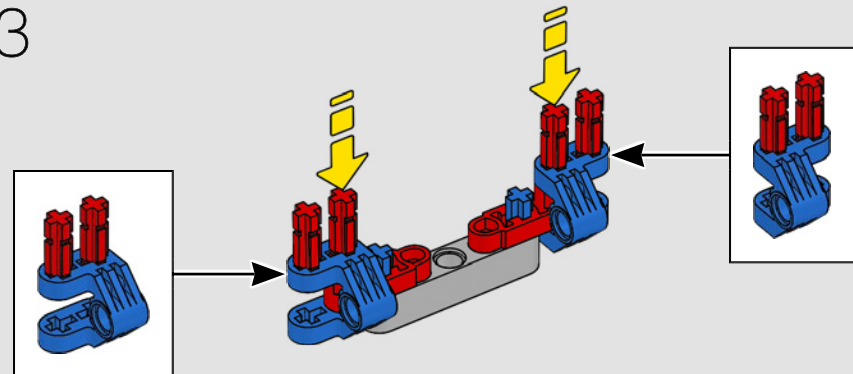

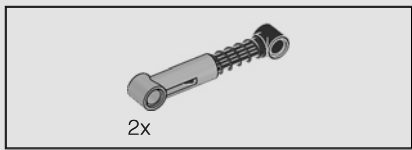

134

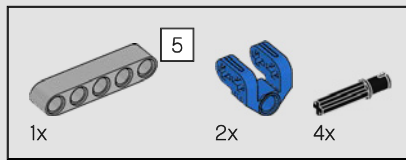
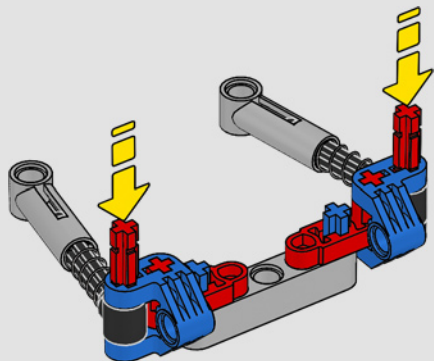

135

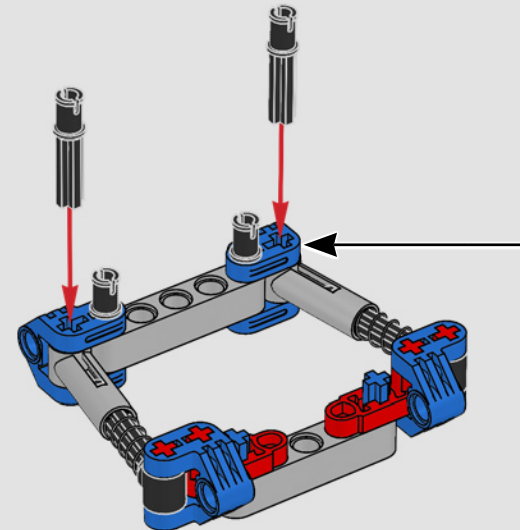
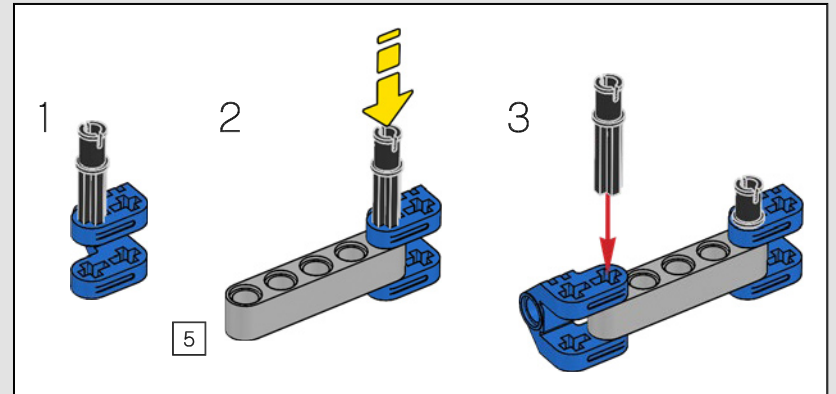
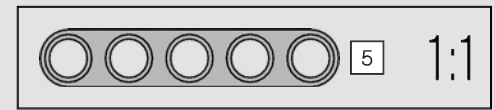

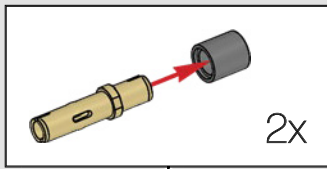
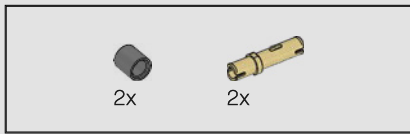

136

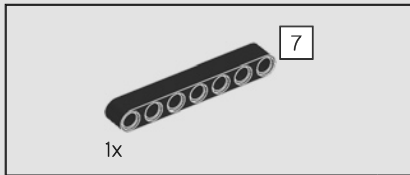
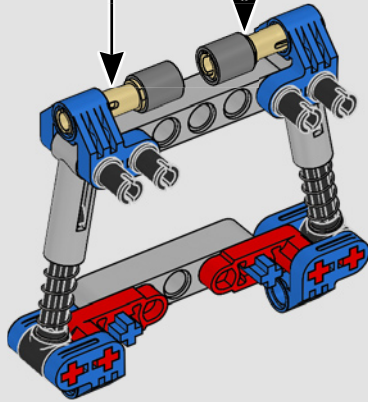

137

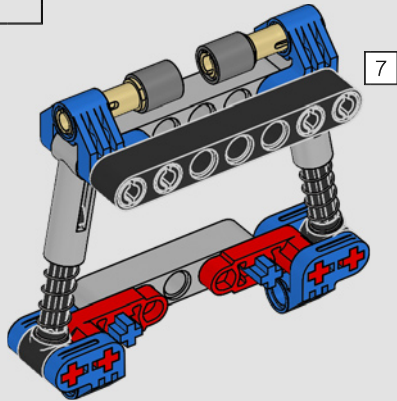

138

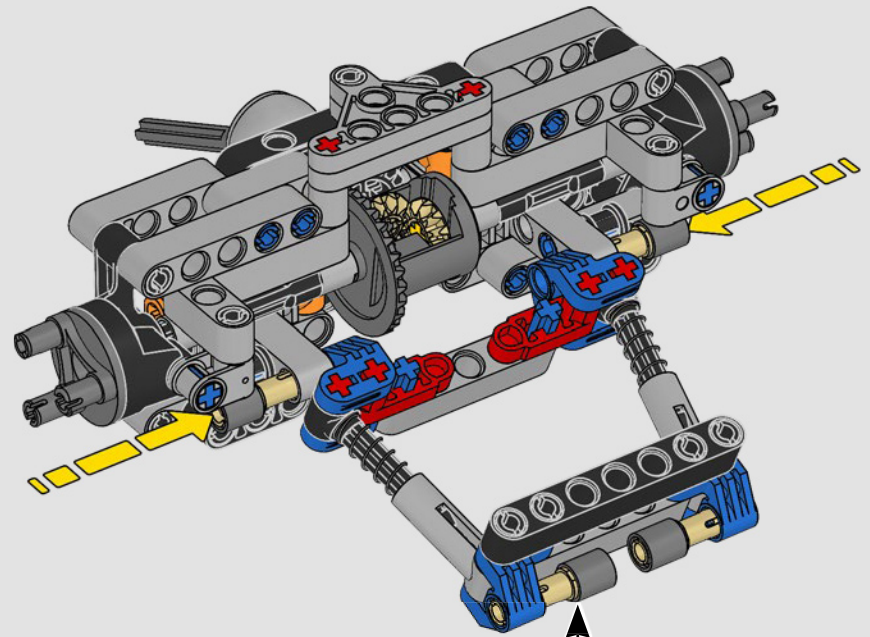

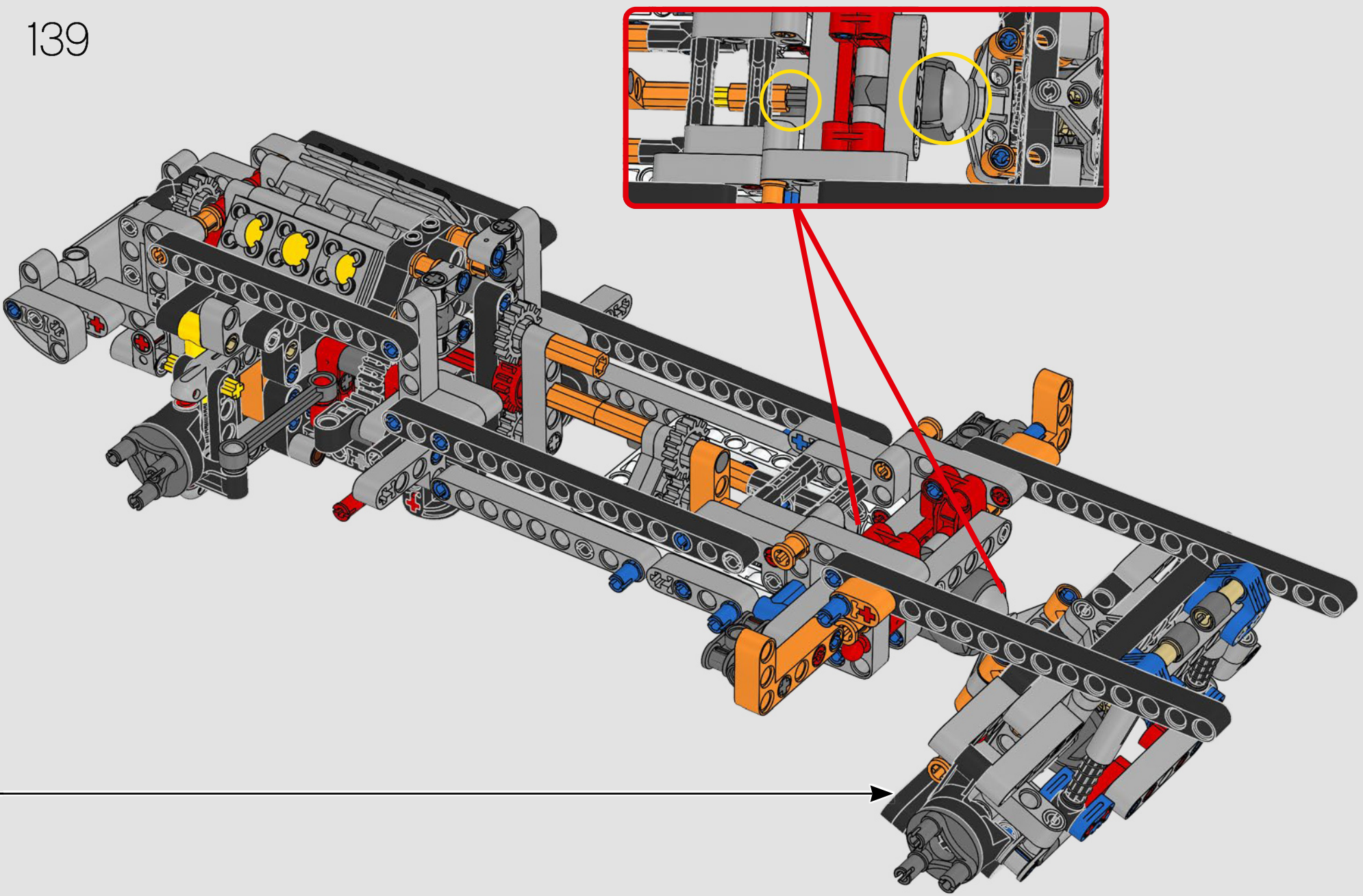

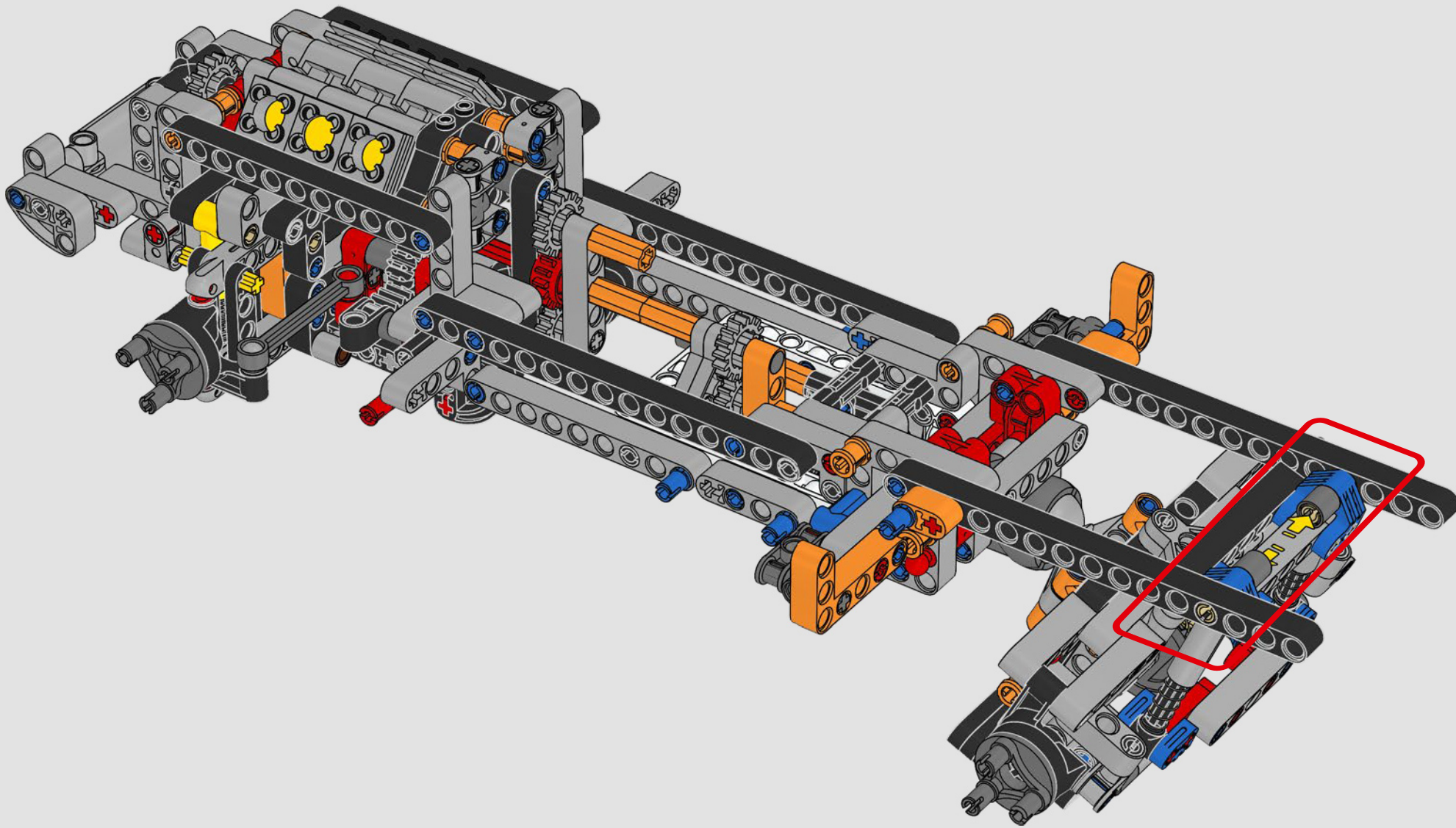

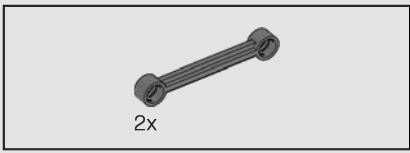

141

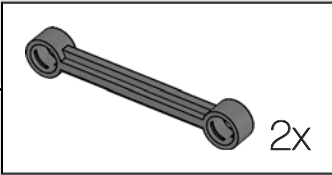
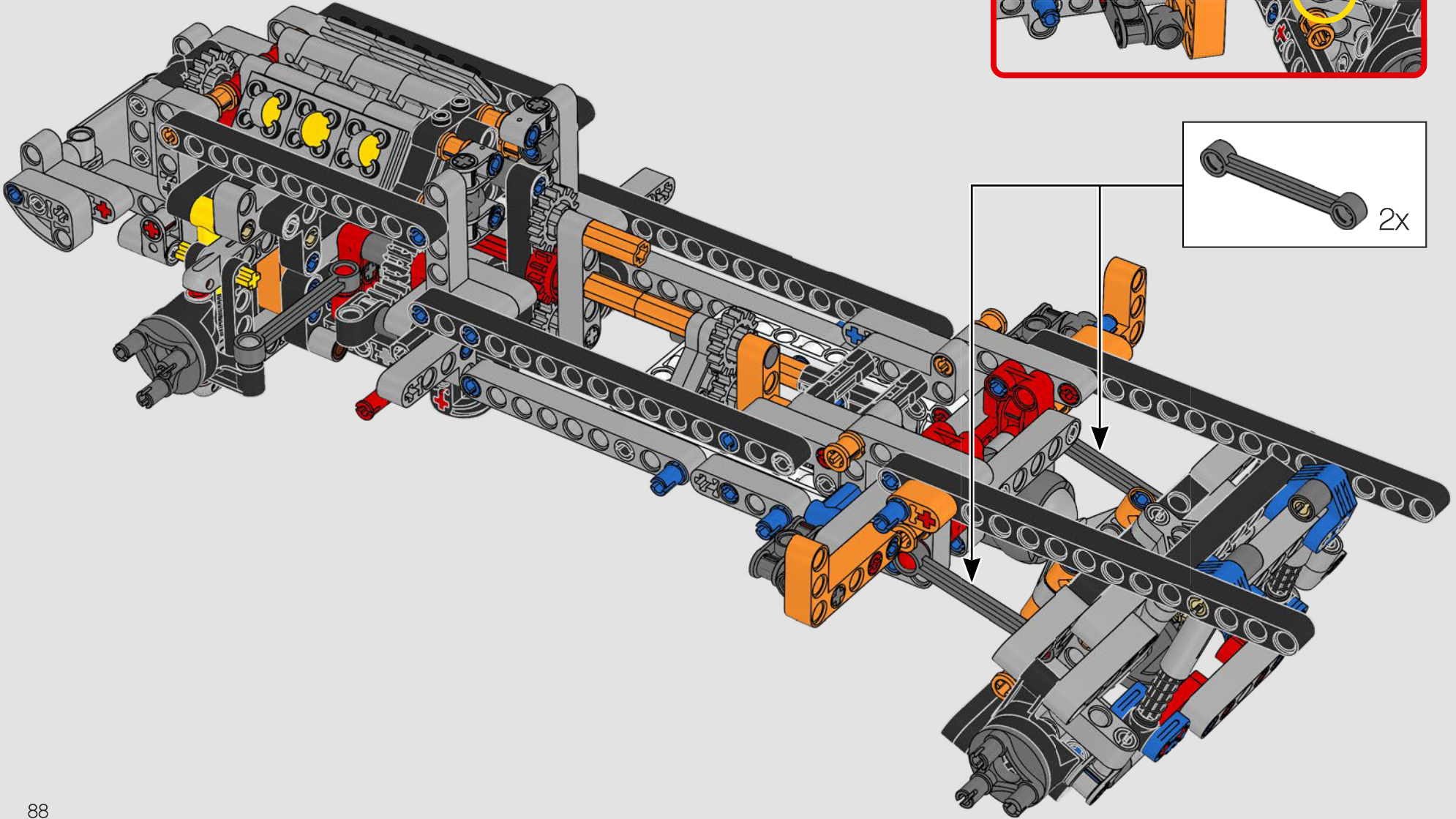
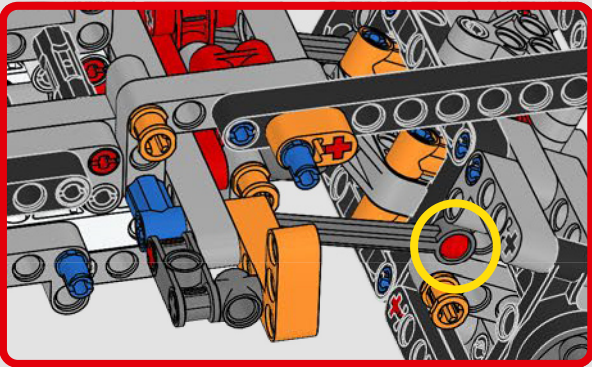



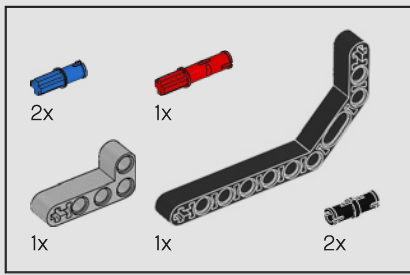

142

1

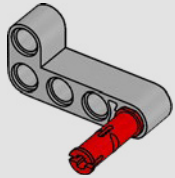

2

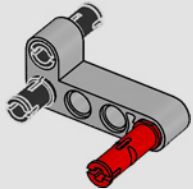

3

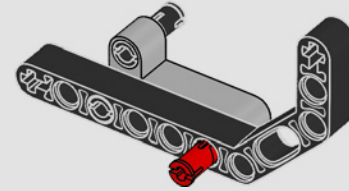

4

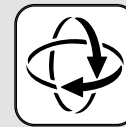
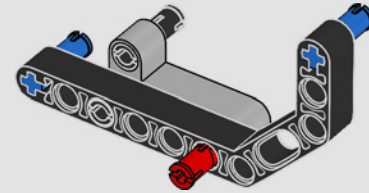

5

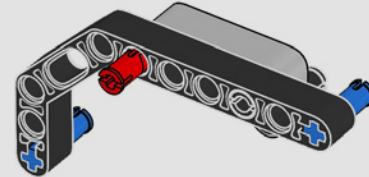

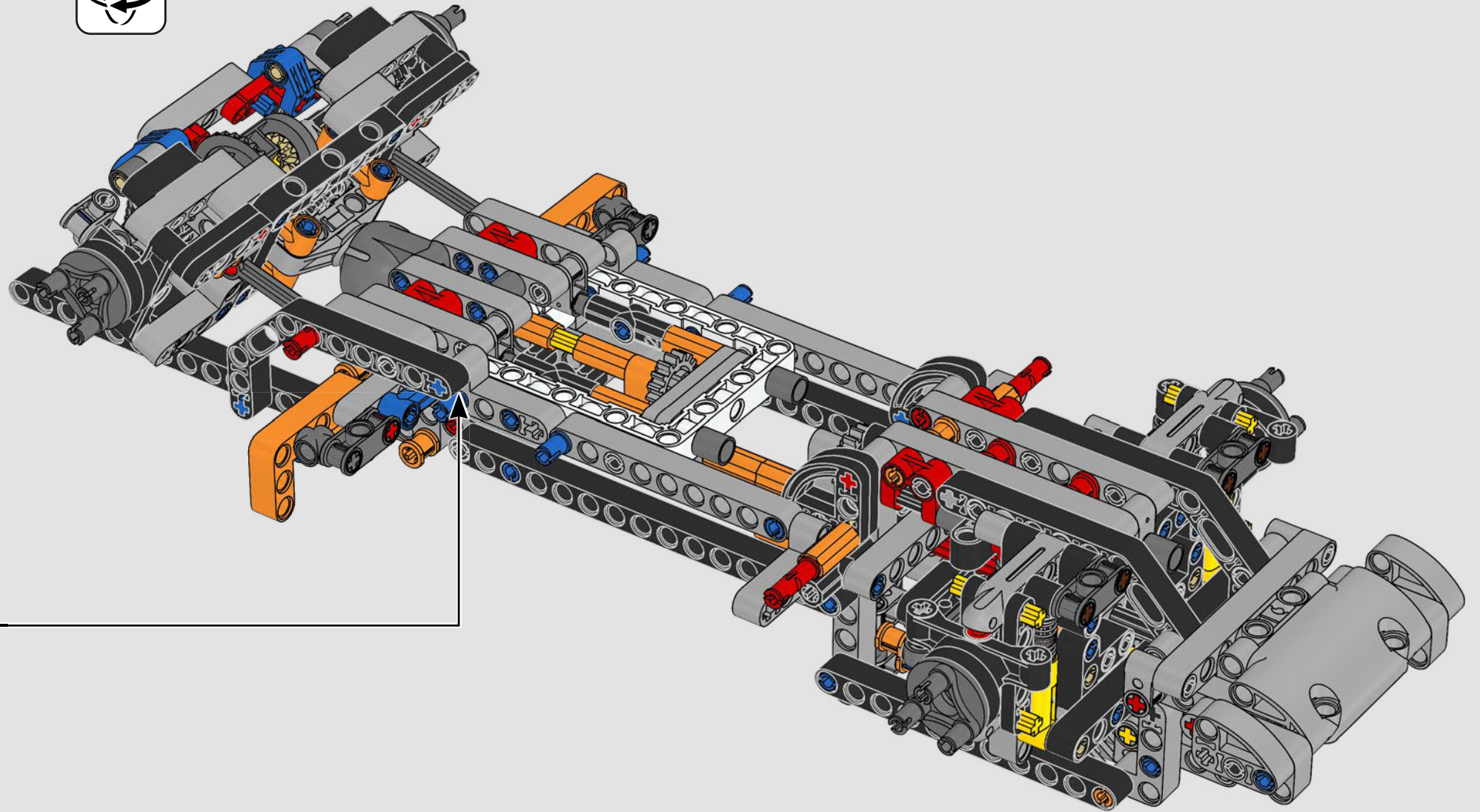

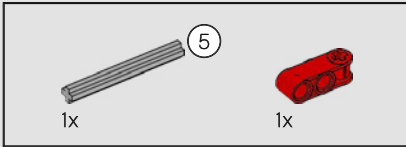
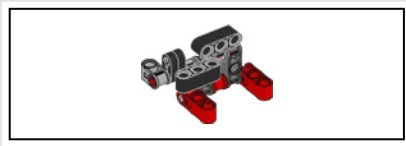

143

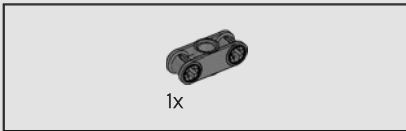
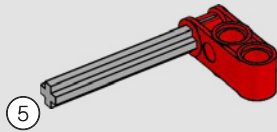

144

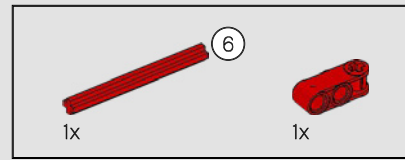
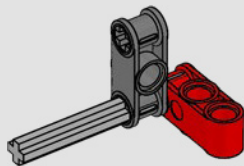

145

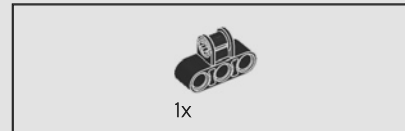
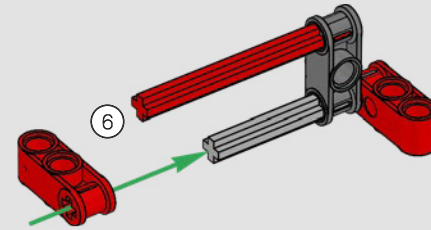

146

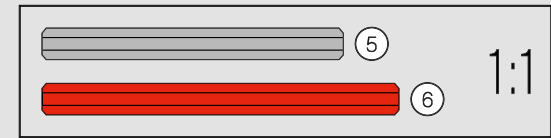
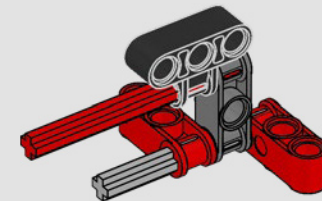

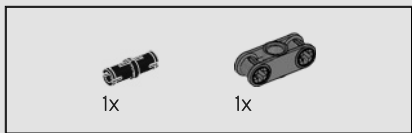

147

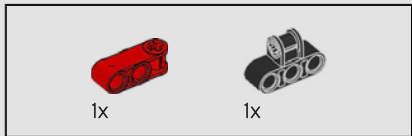
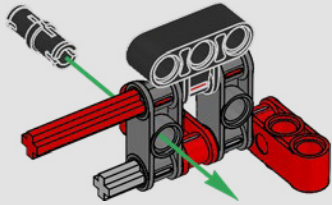

148

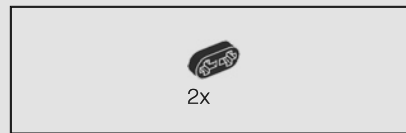
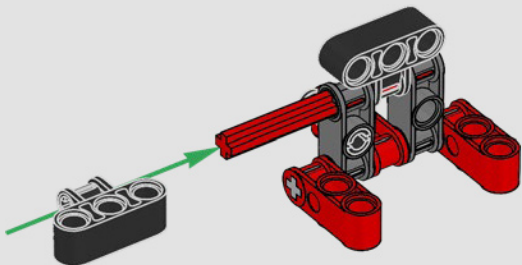

149

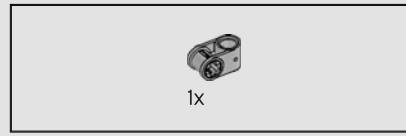
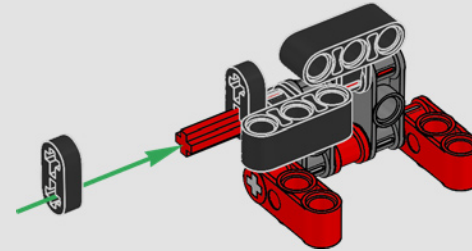

150

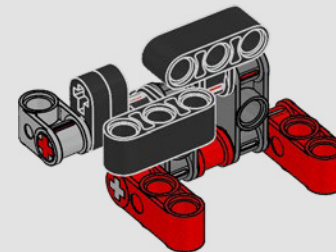

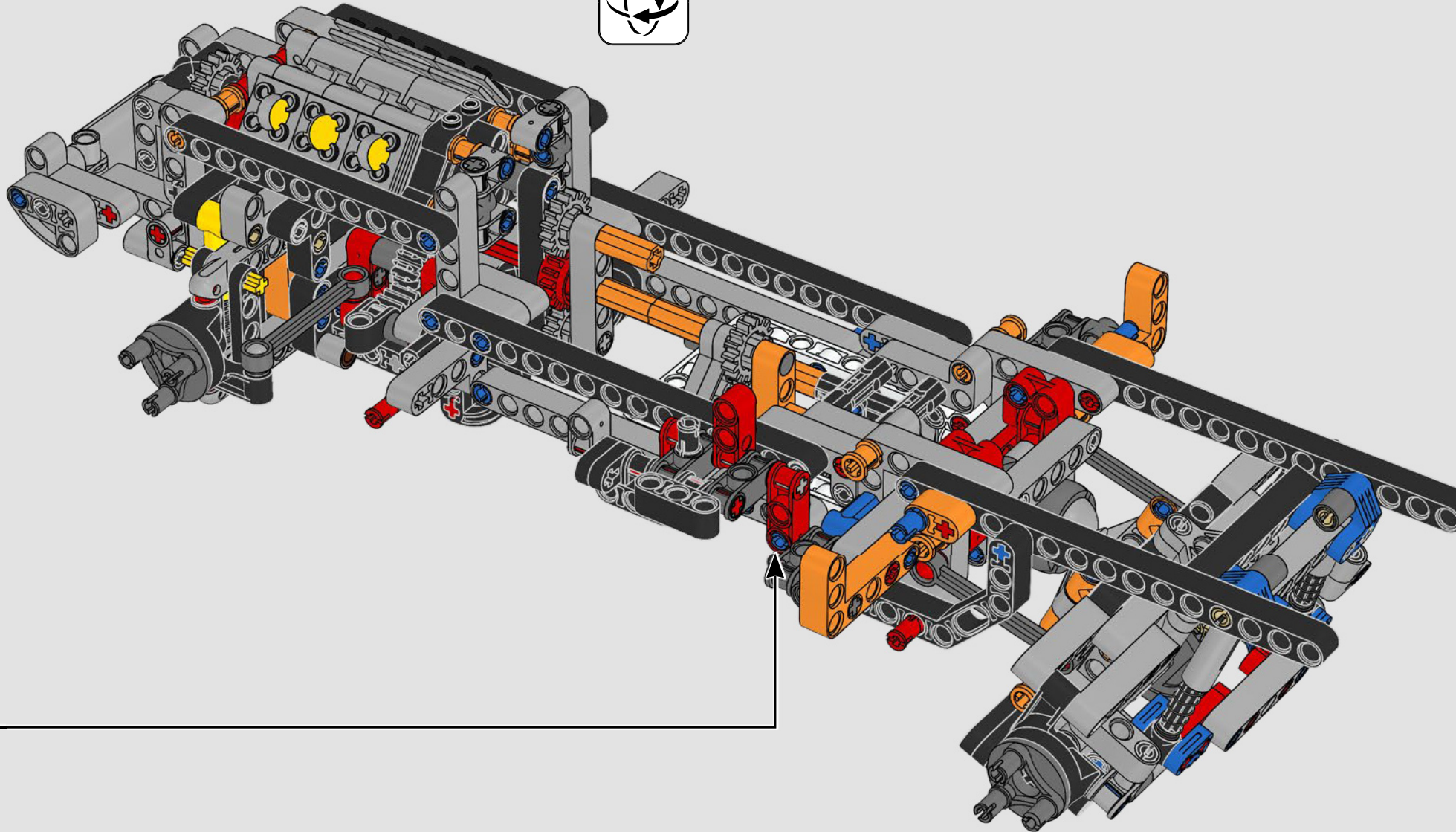

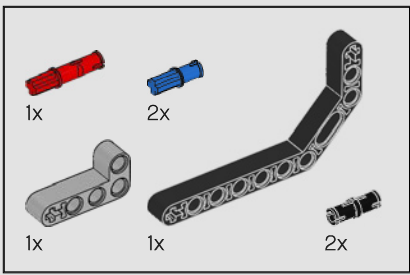

152

1

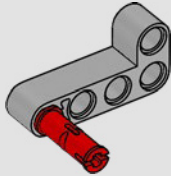

2

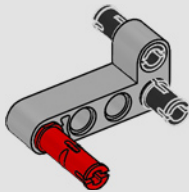

3

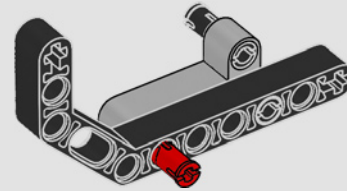

4

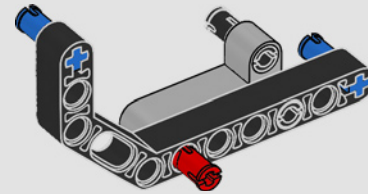

5

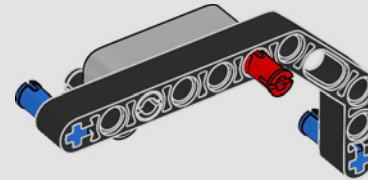
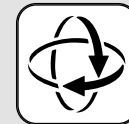

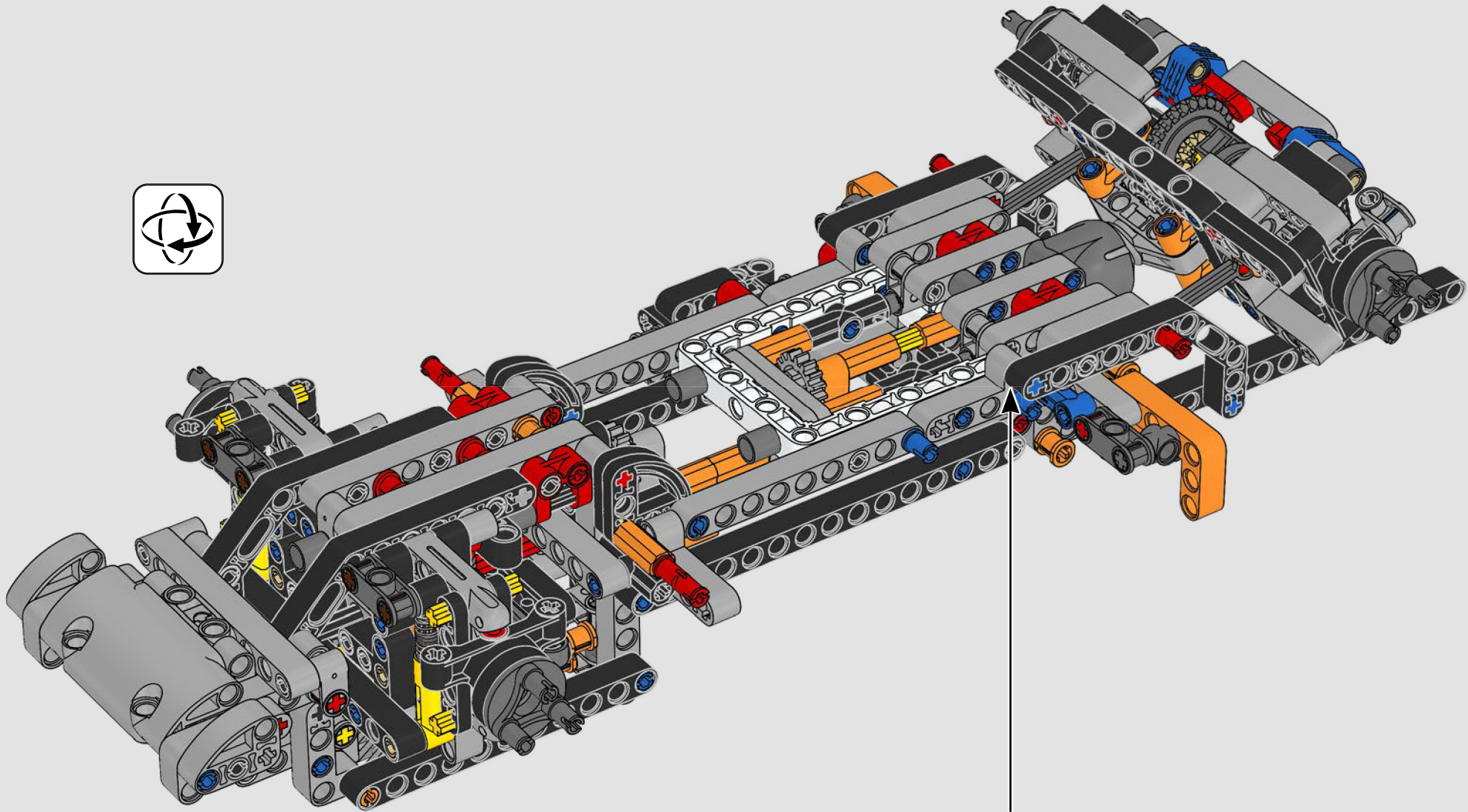

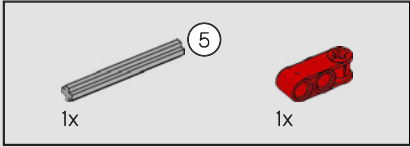

153

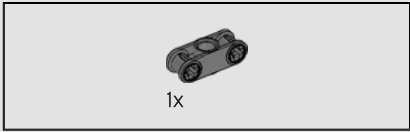
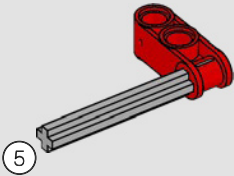

154

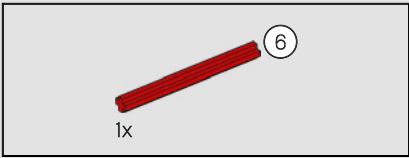
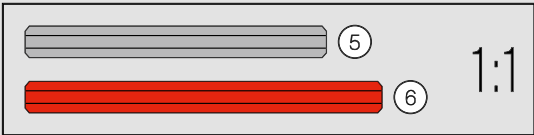
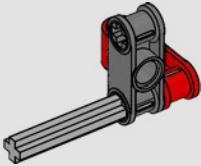

155

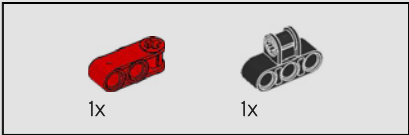
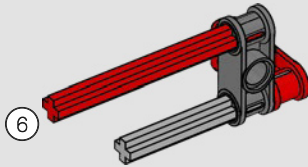

156

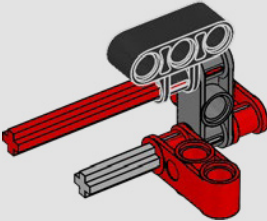



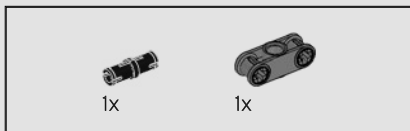

157

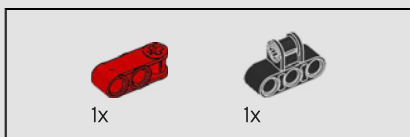
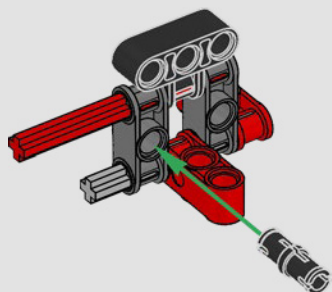

158

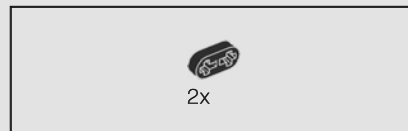
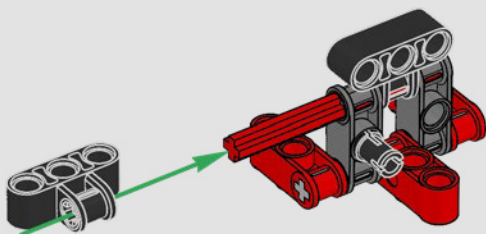

159

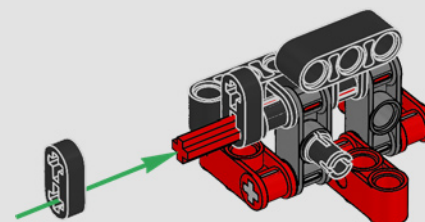

160

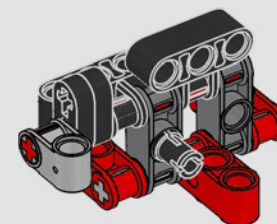

161

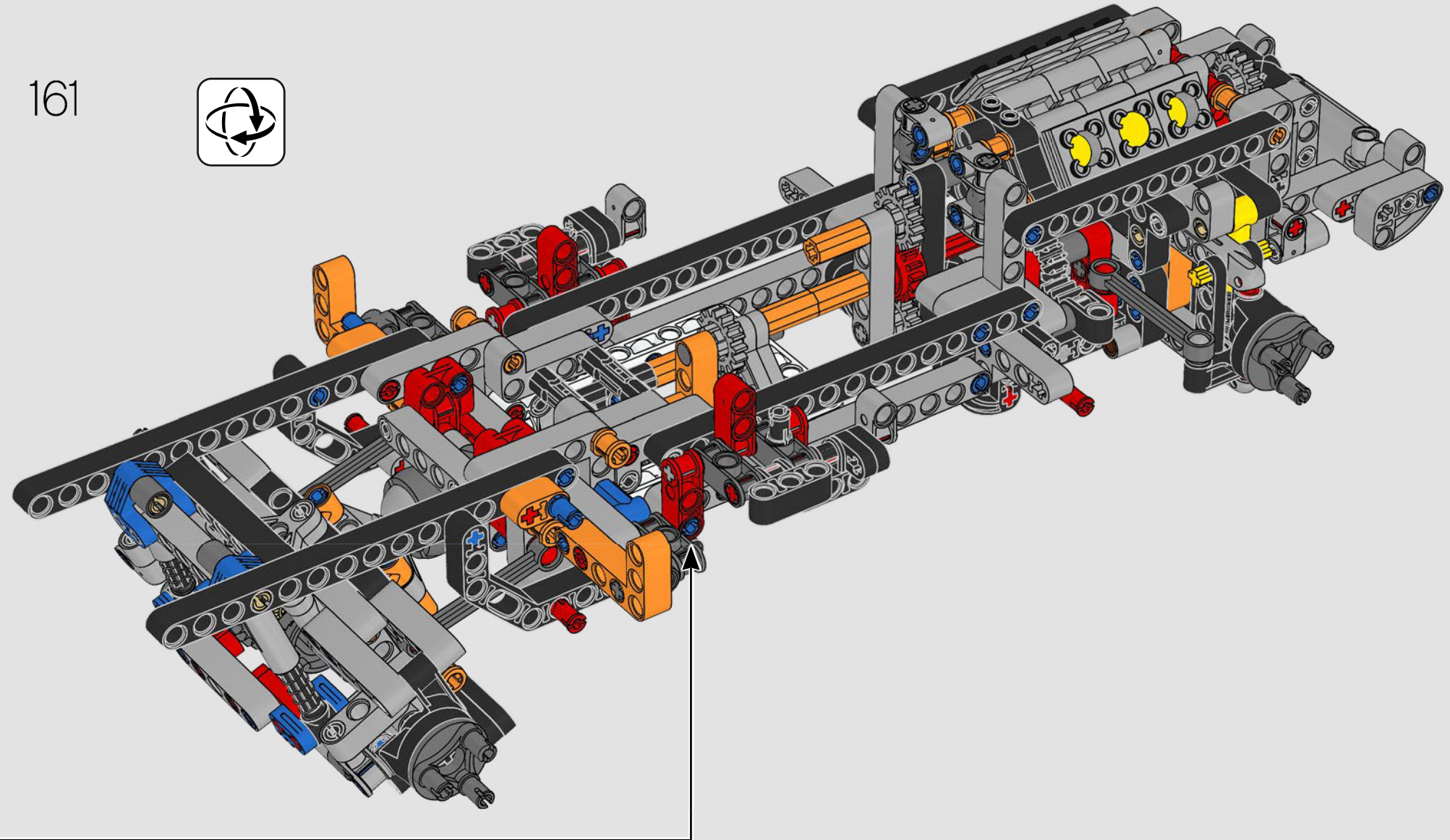

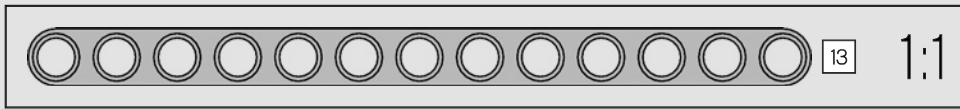
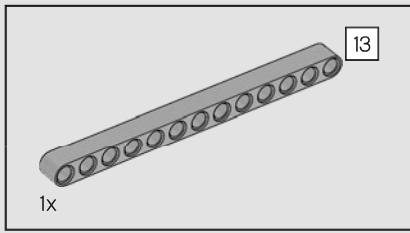

162

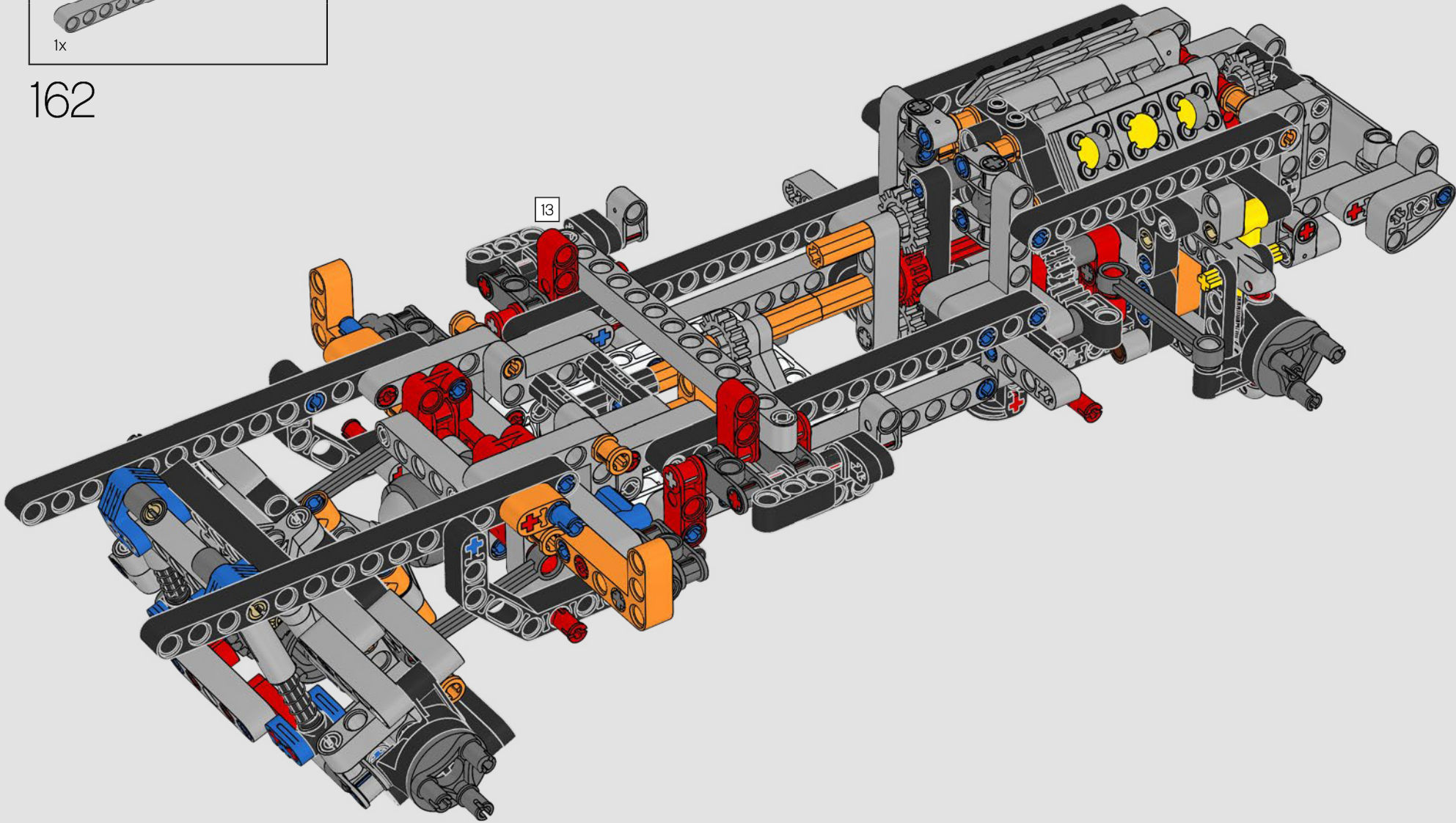

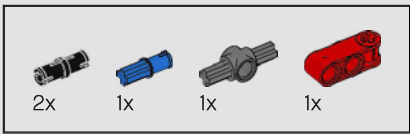

163

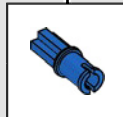
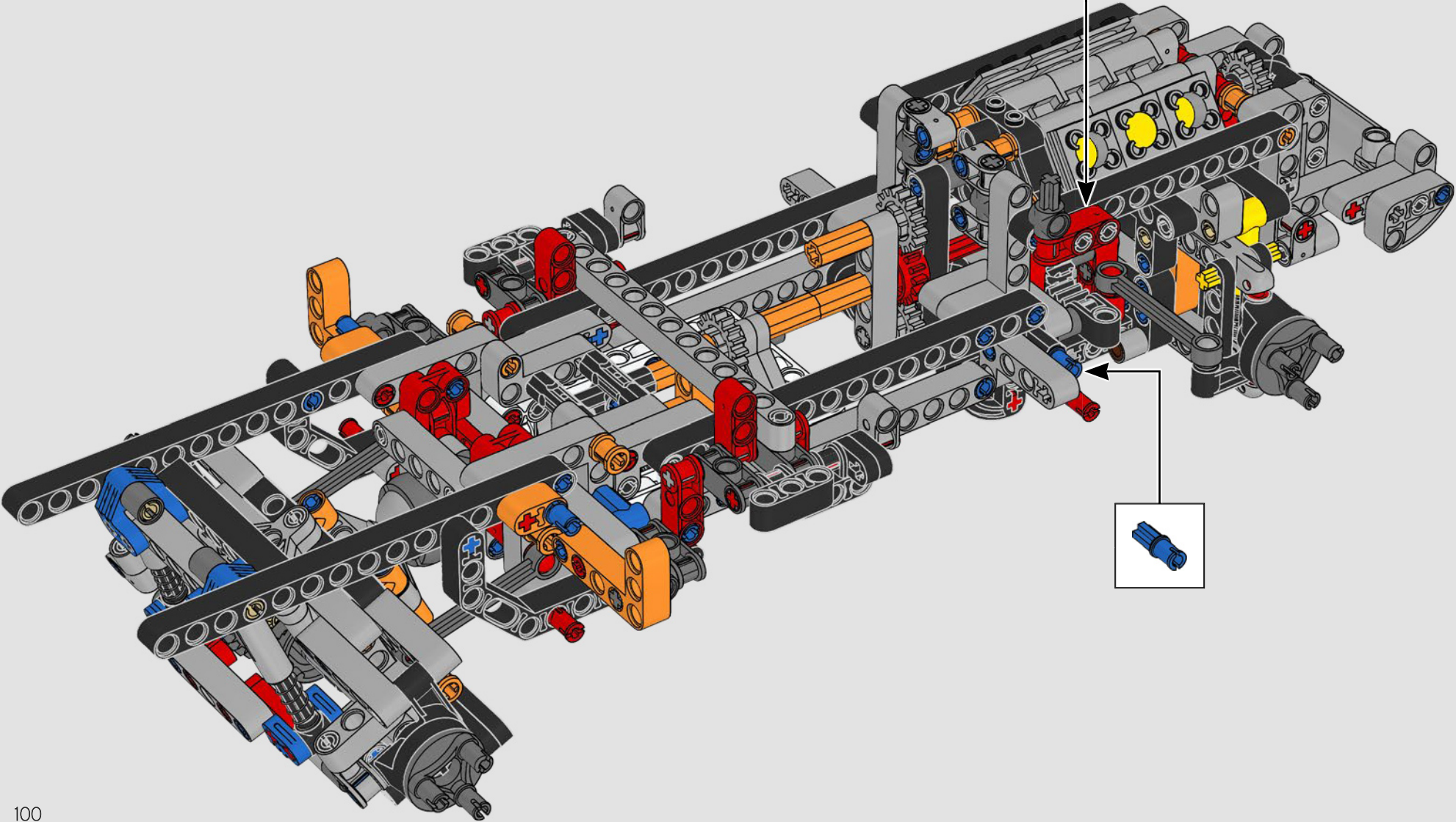
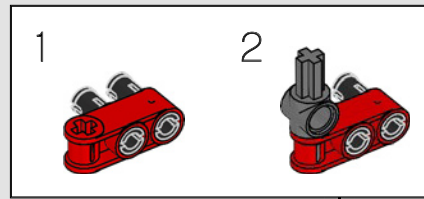

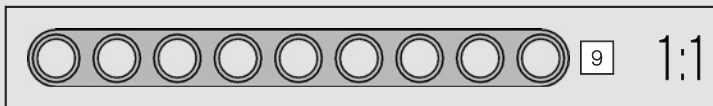
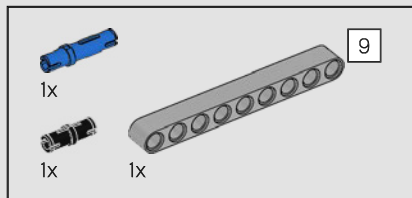

164

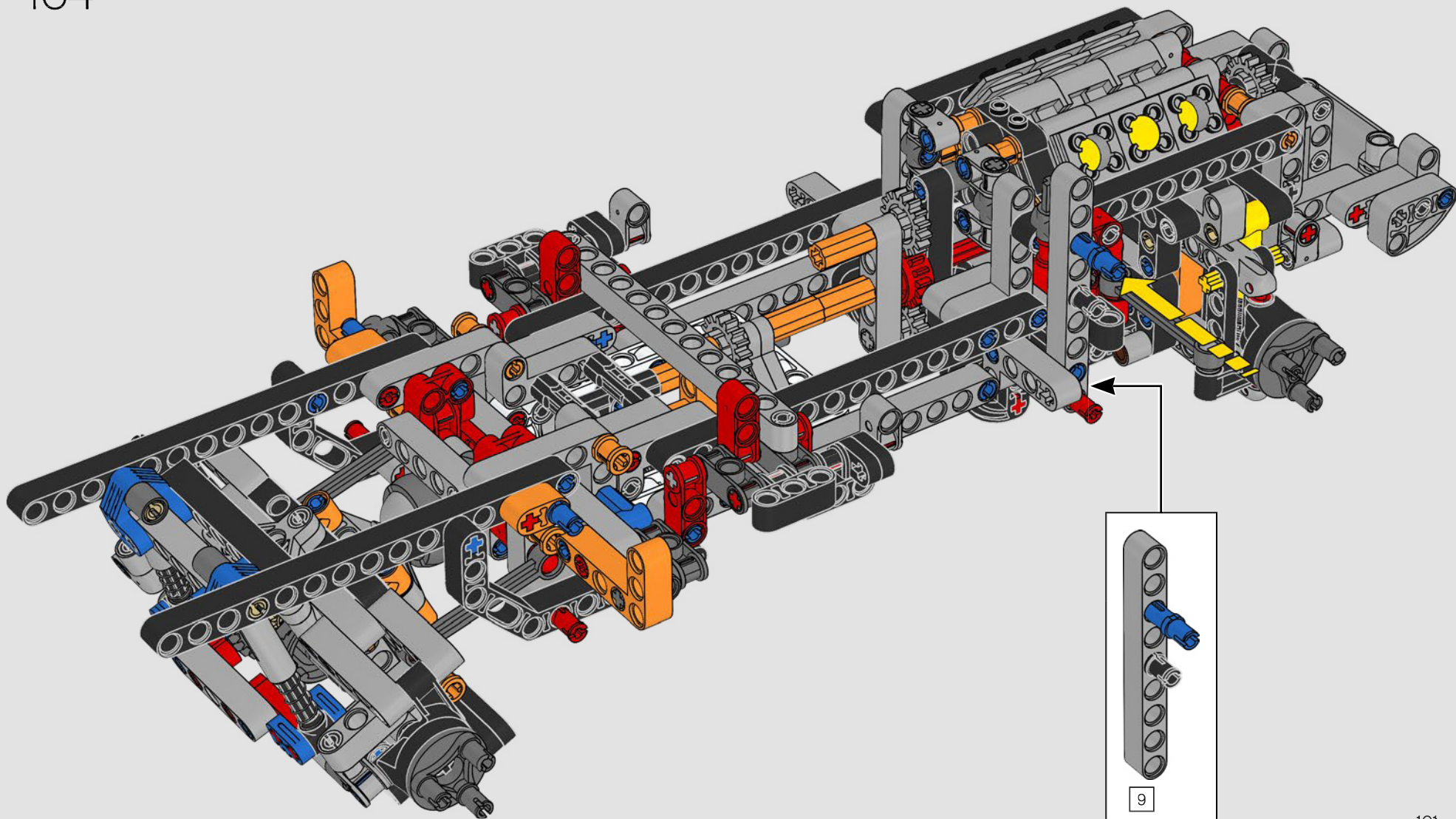

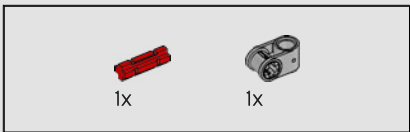

165

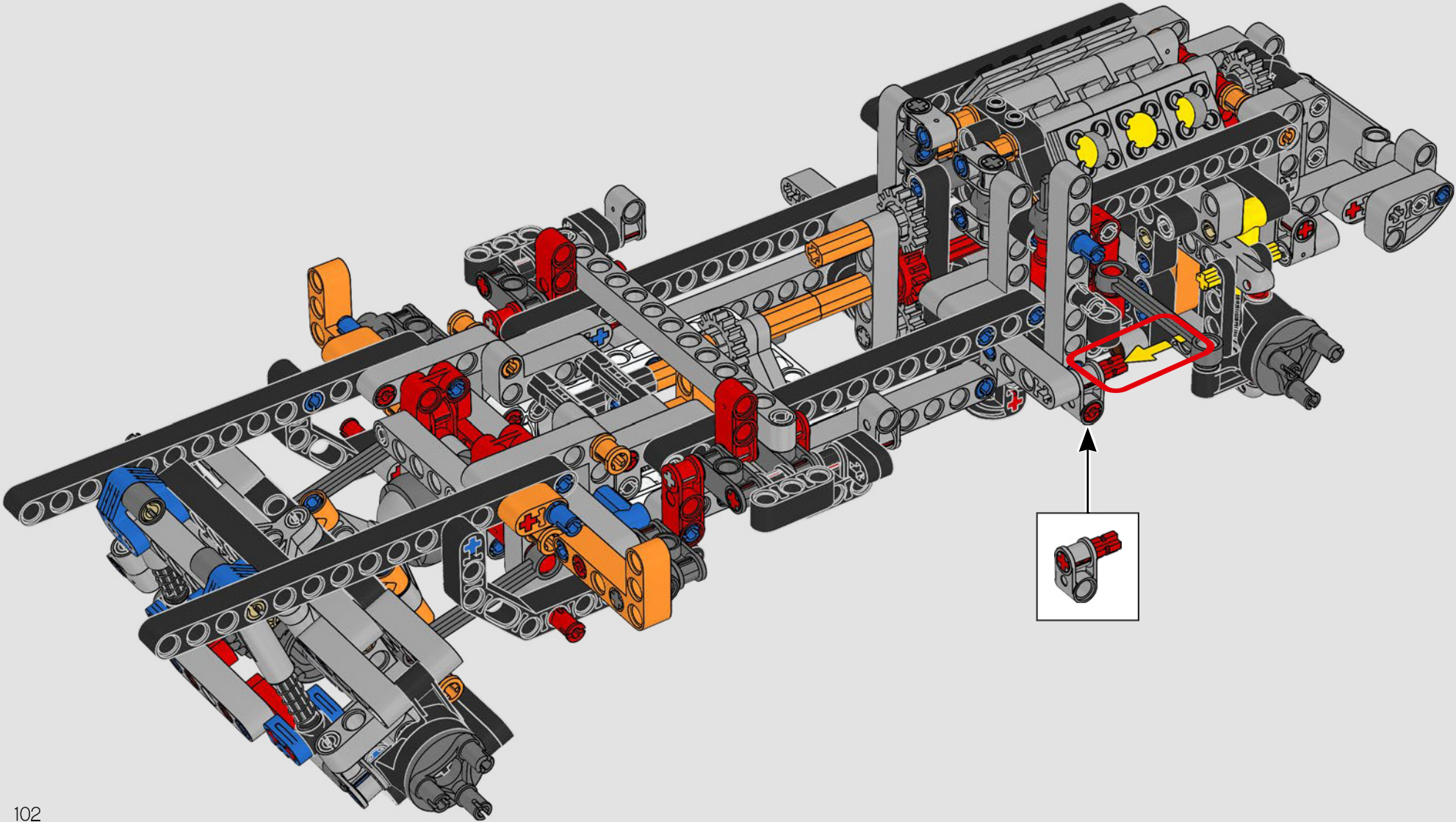

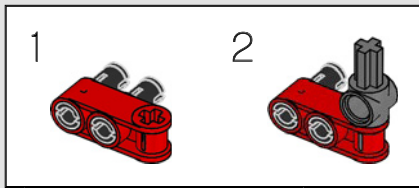
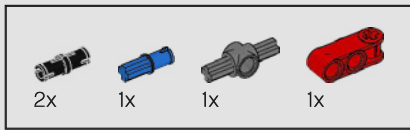

166

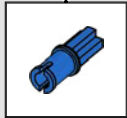
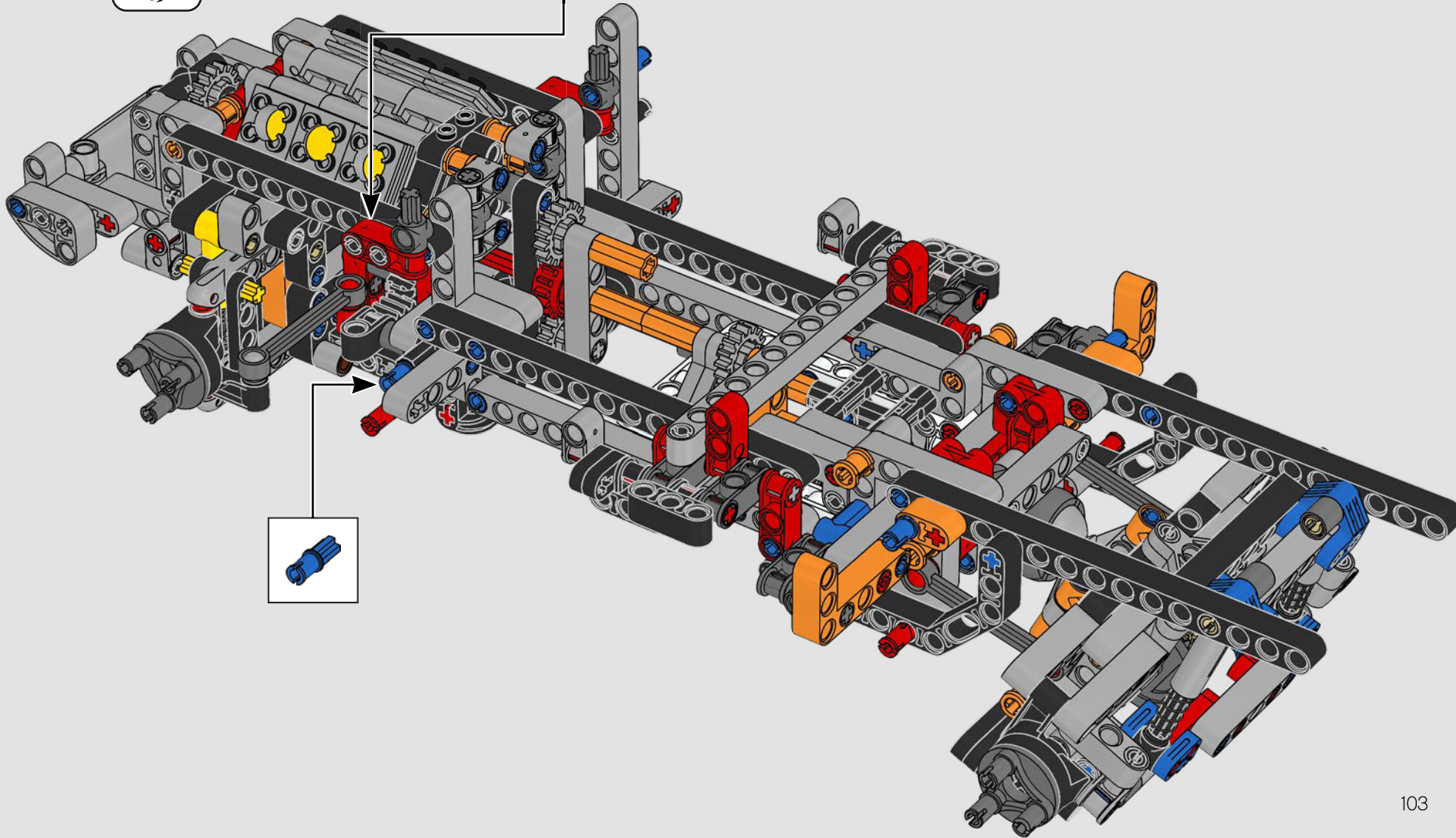

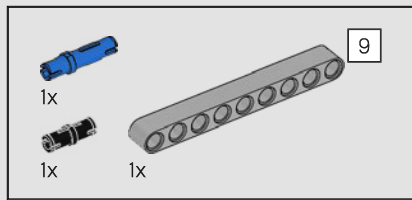

167

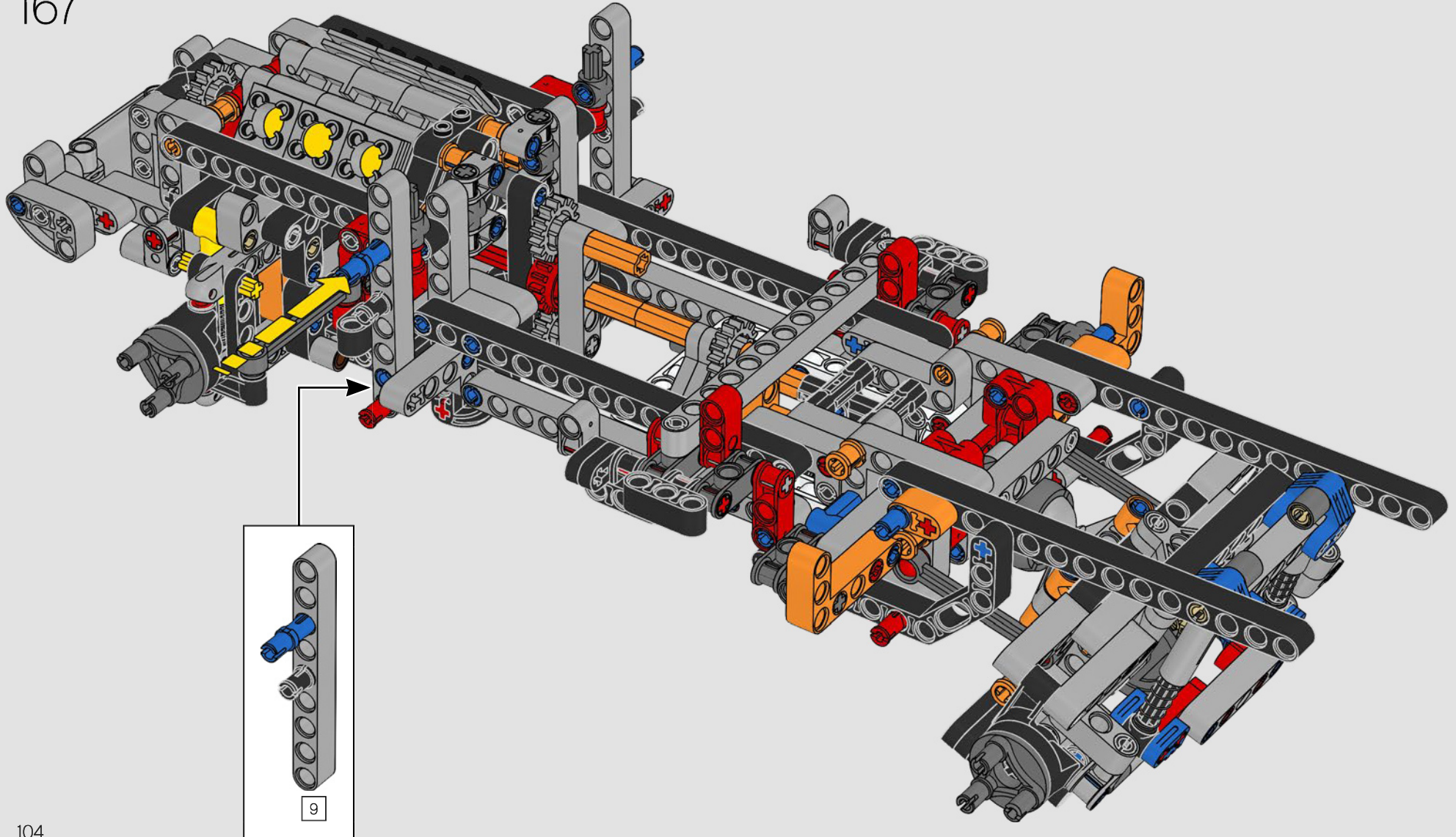



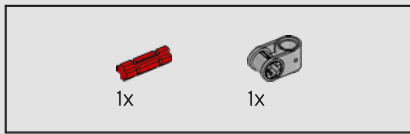

168

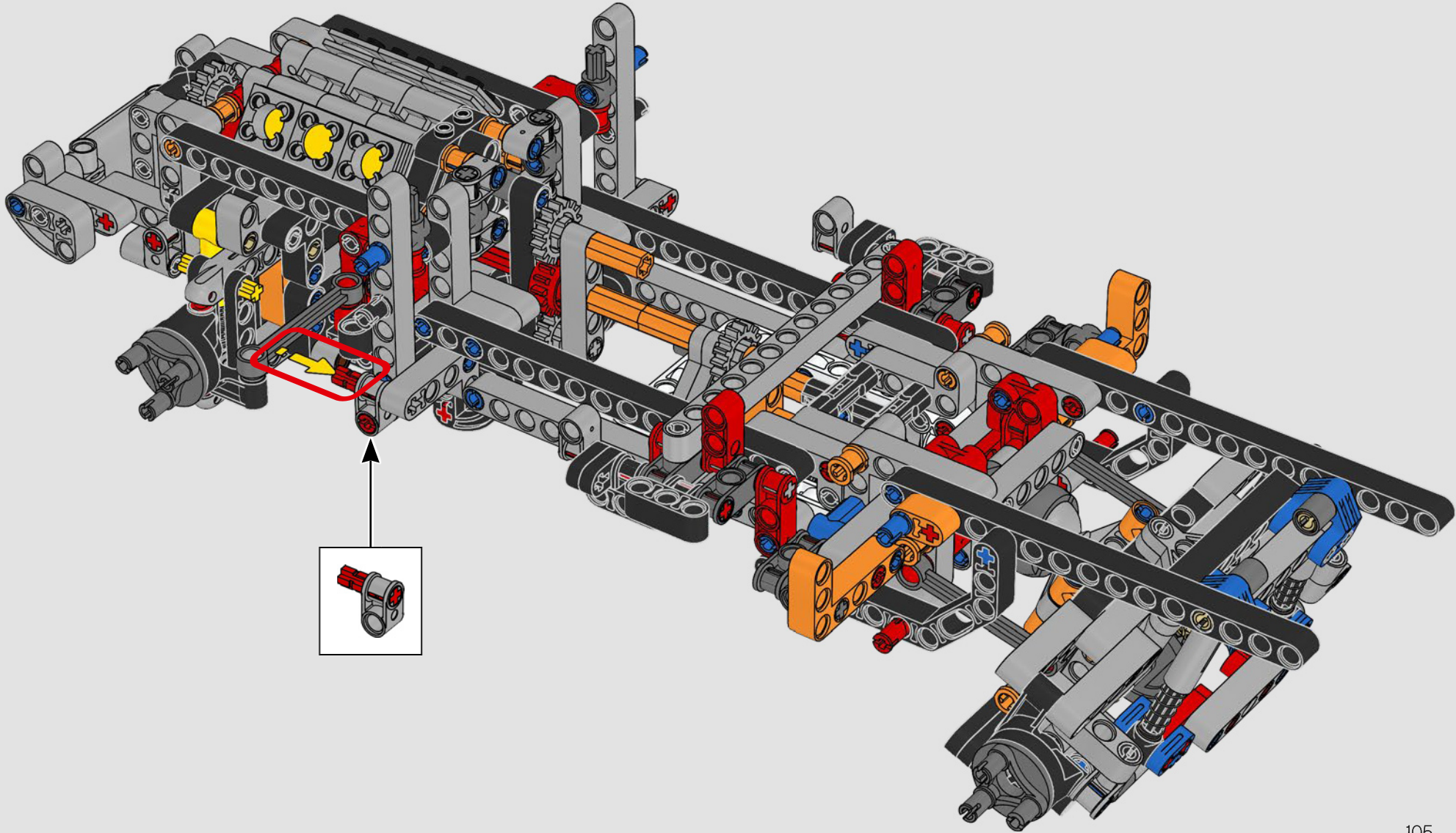

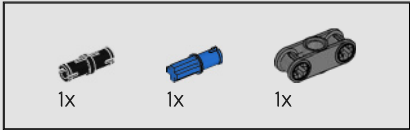
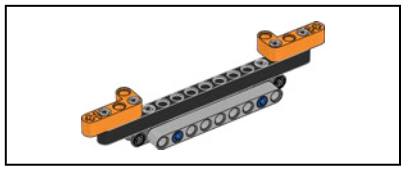

169

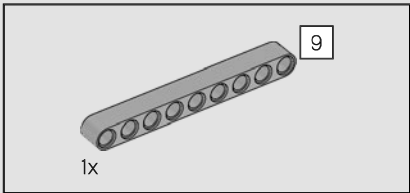
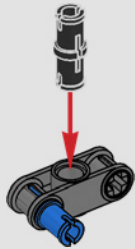

170

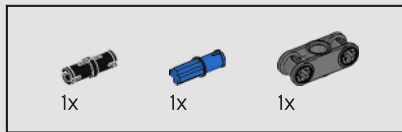
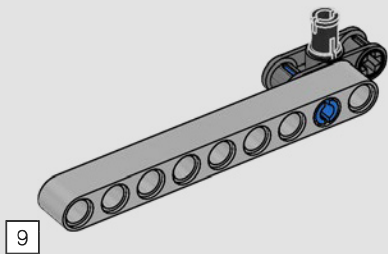

171

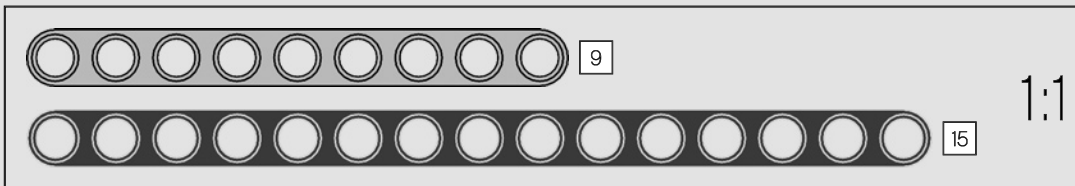
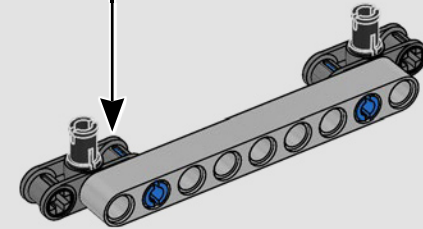
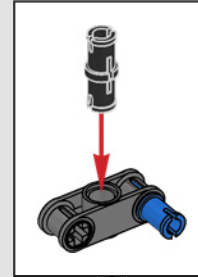

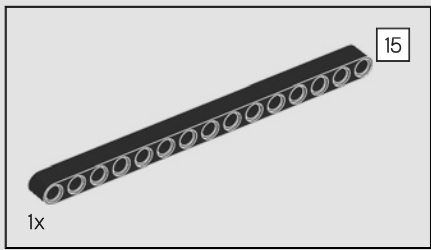

172

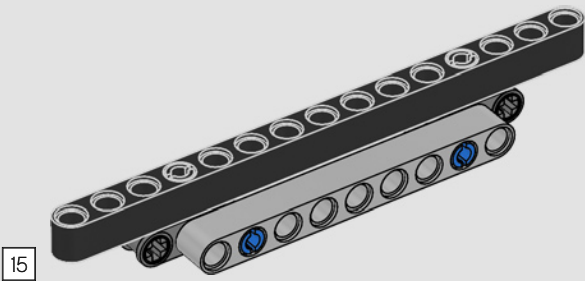

173

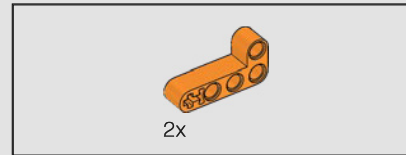
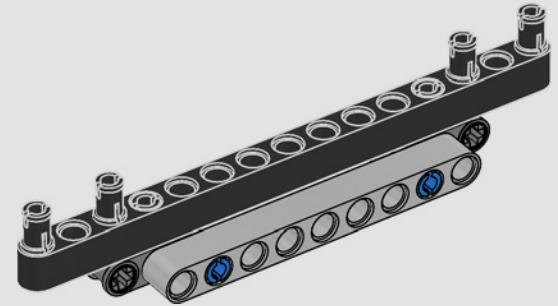

174

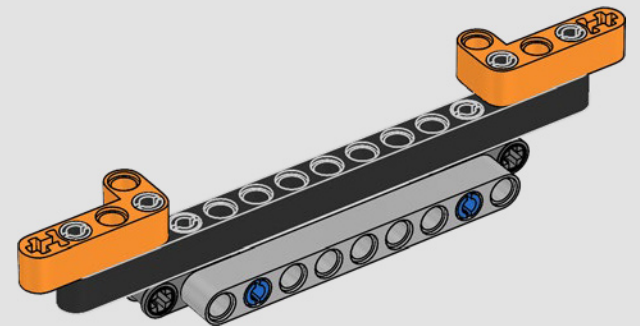

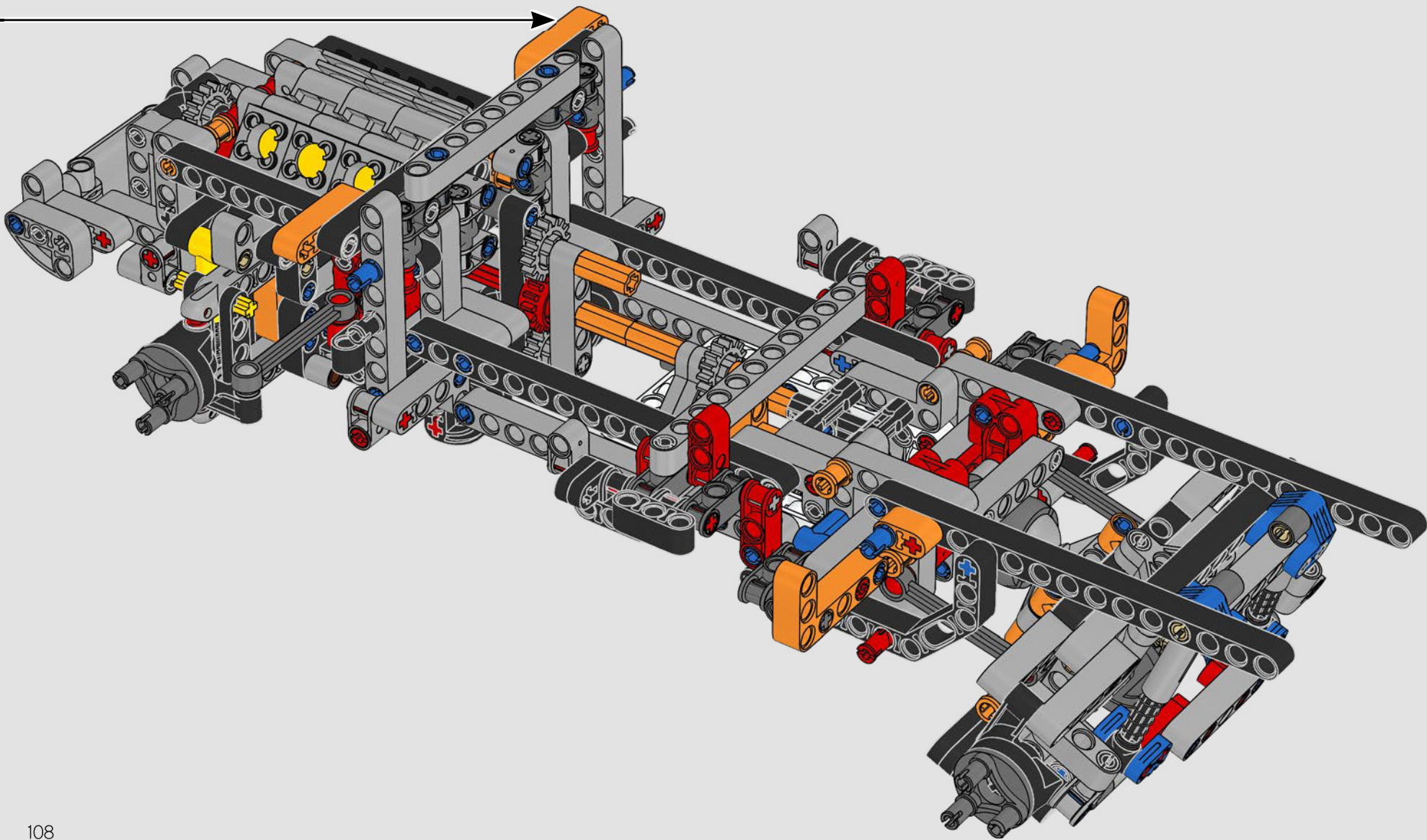



176

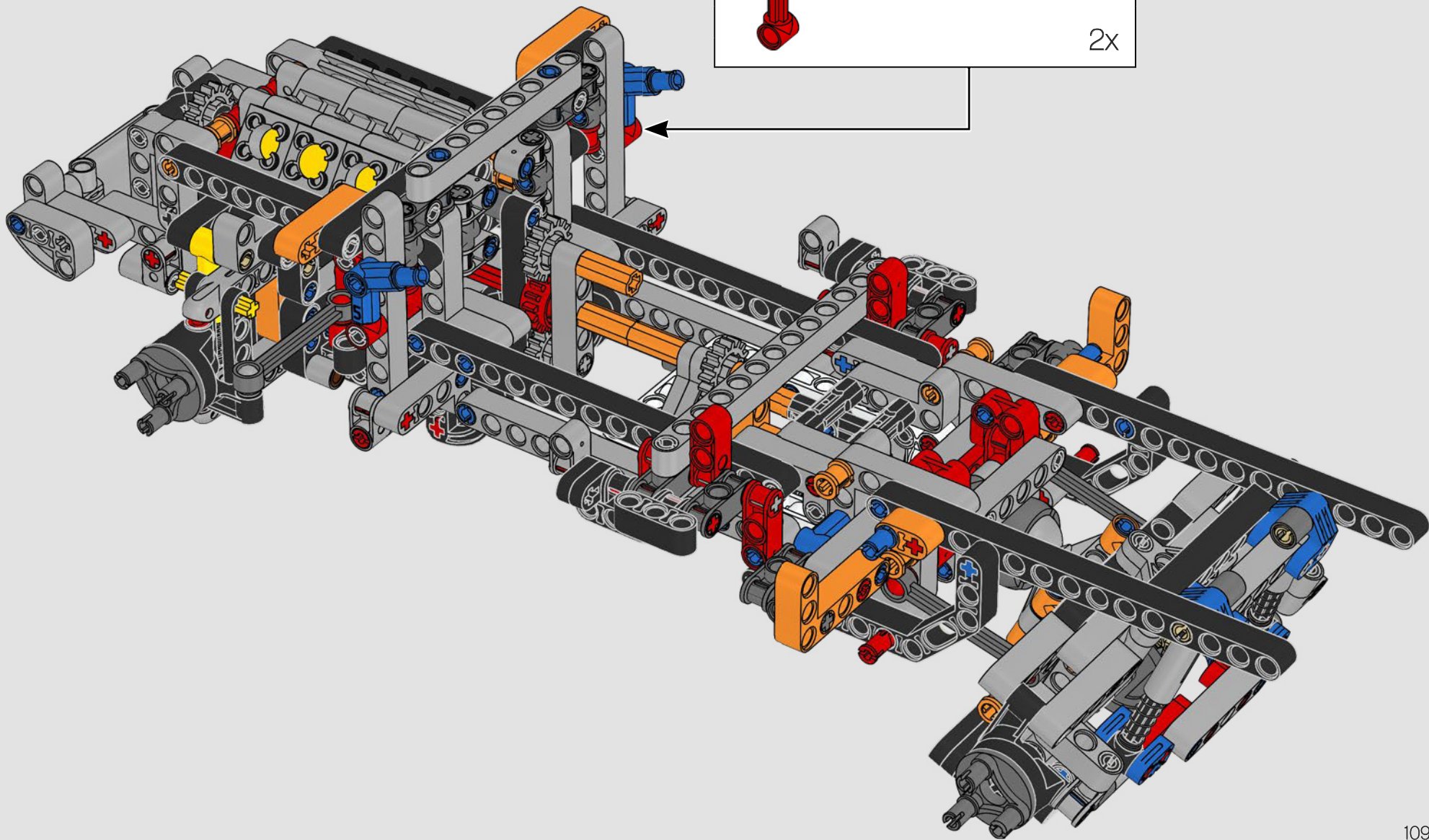
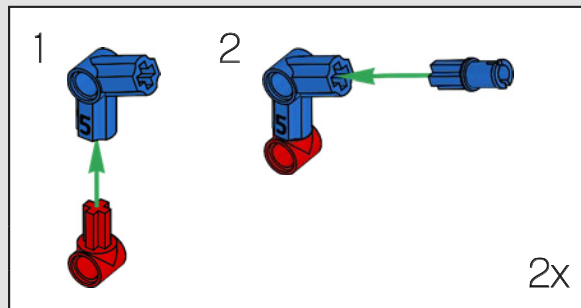

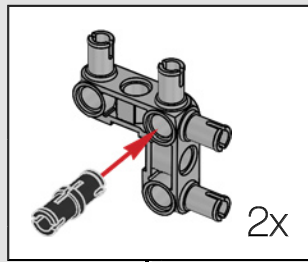
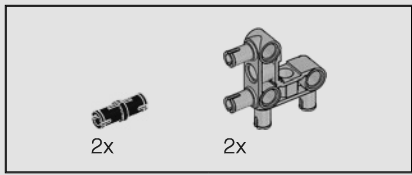

177

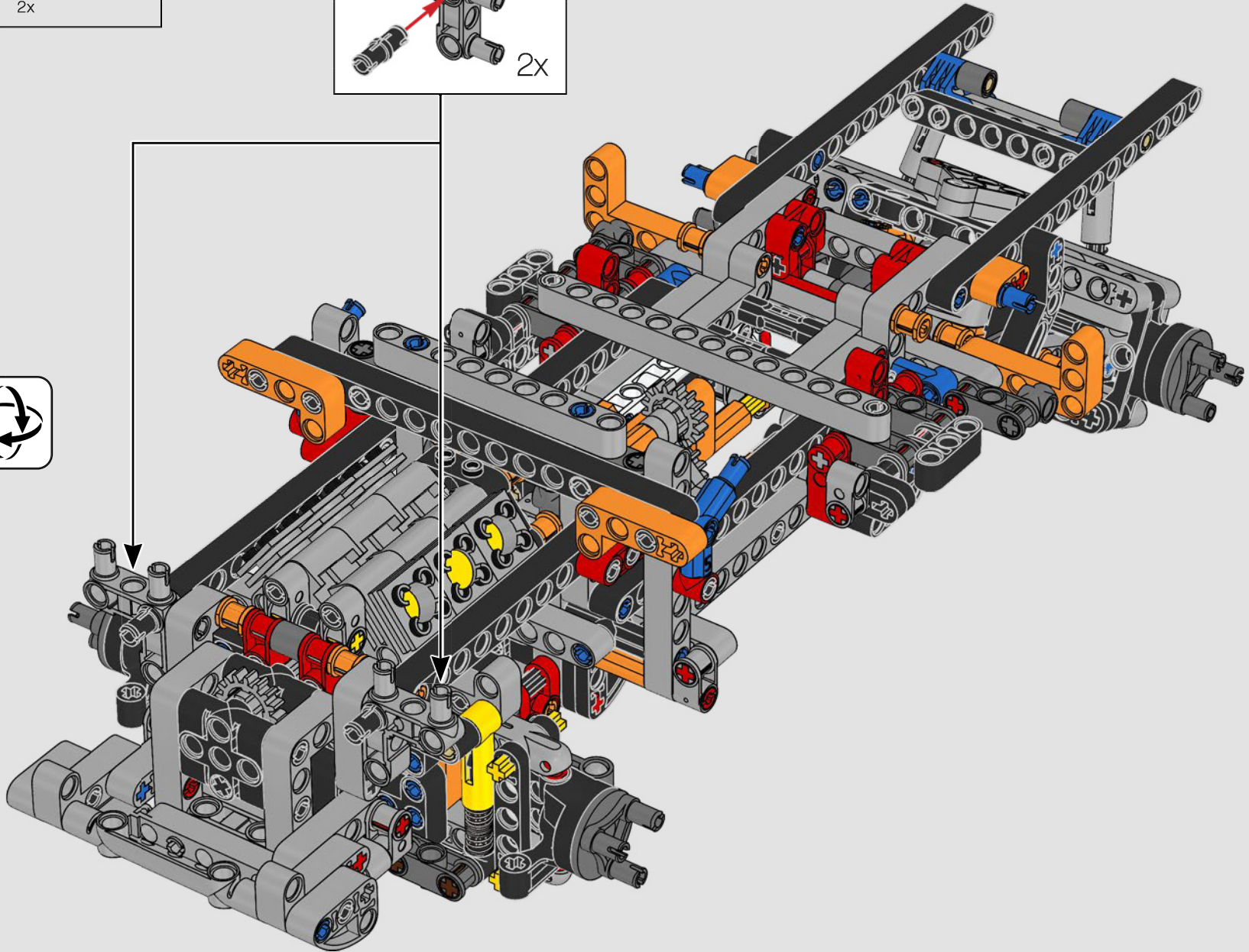

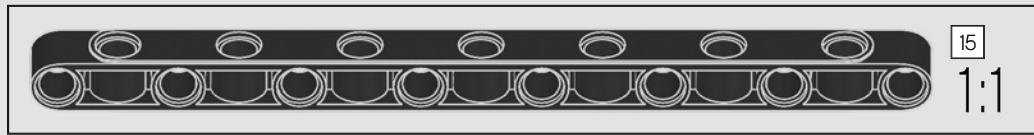
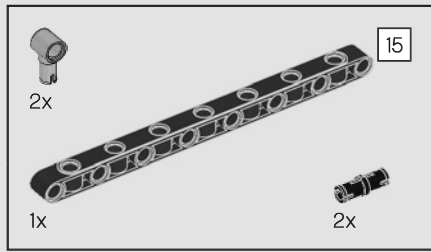

178

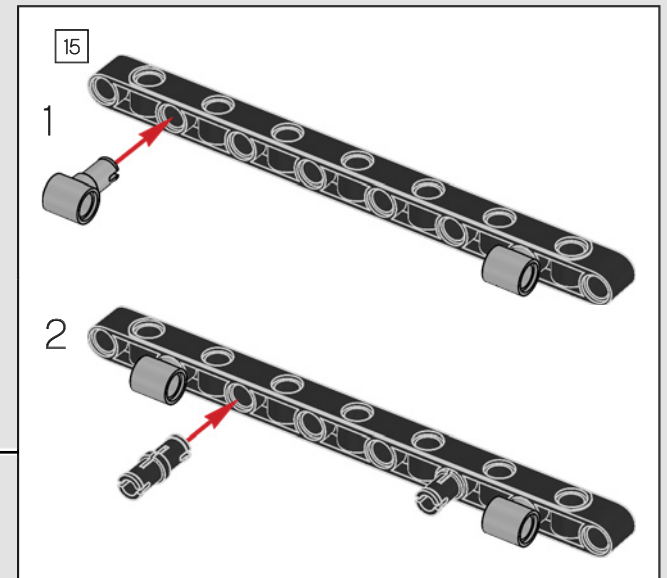
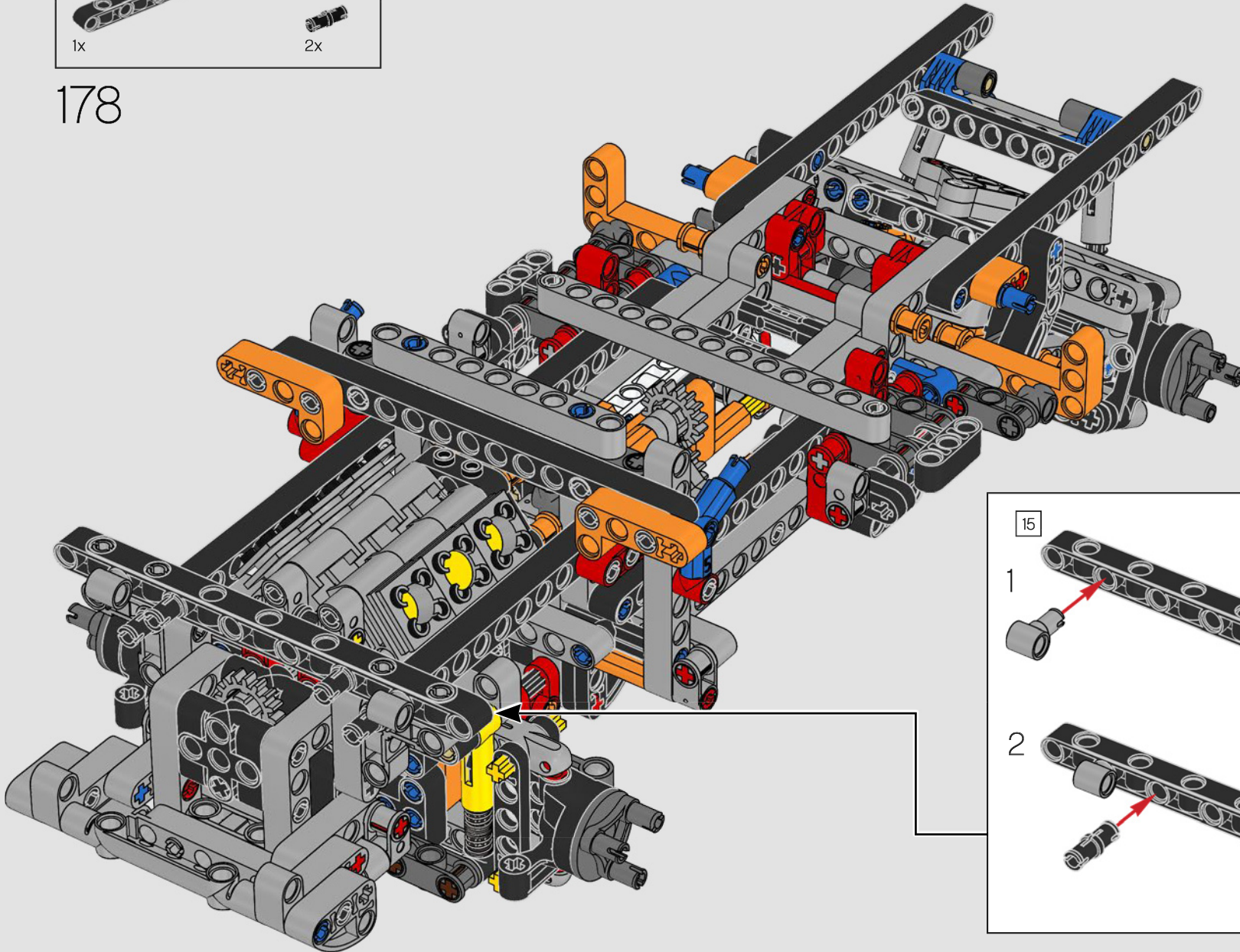

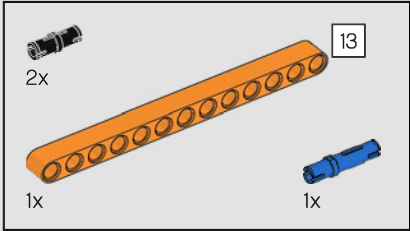
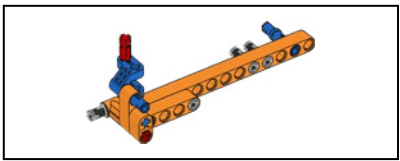

179

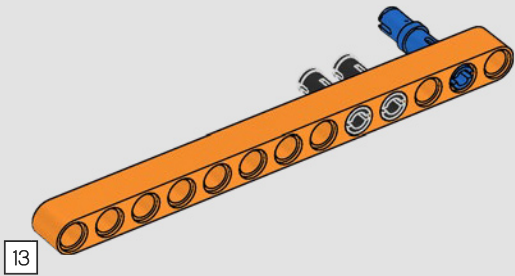

13

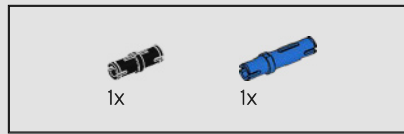

180

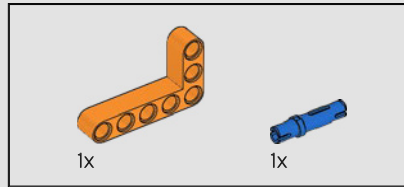
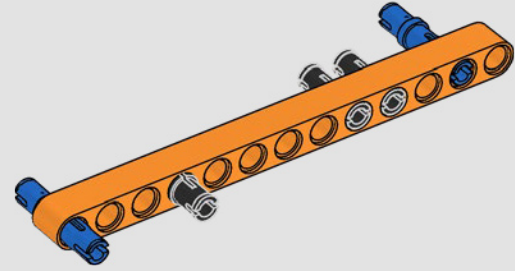

181

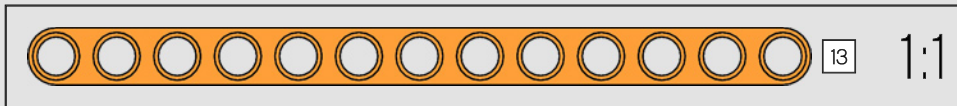
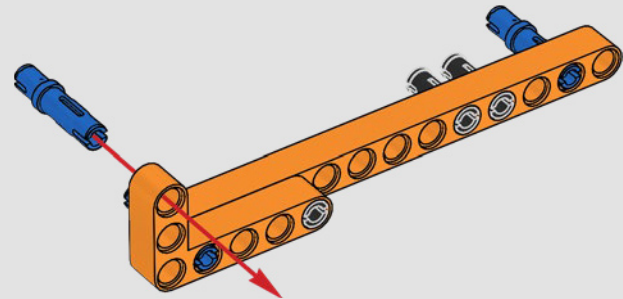



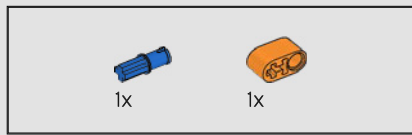

182

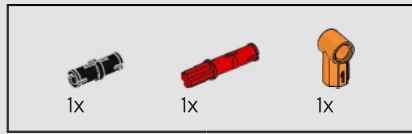
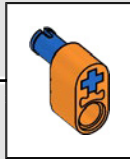
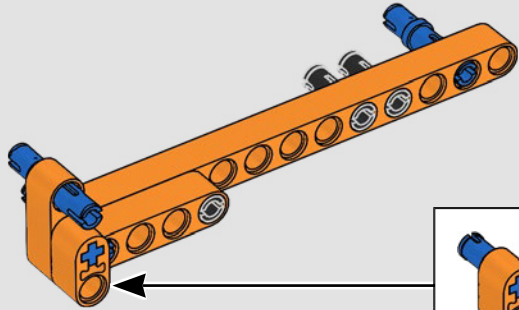

183

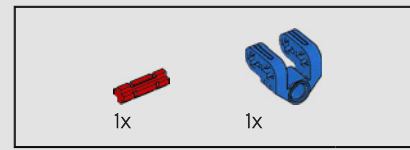
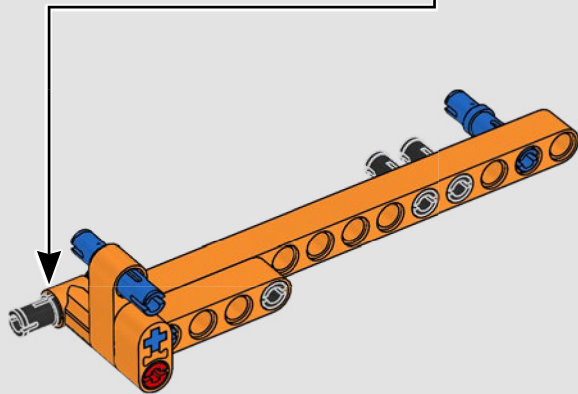
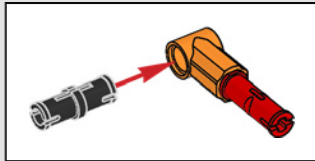

184

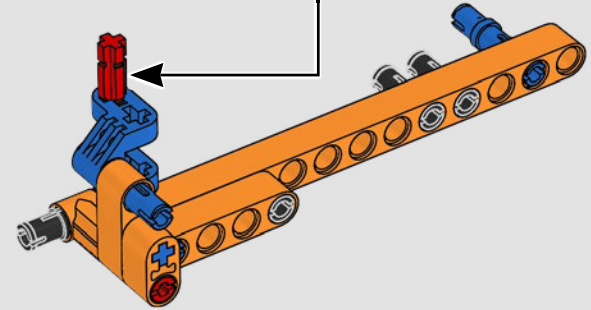
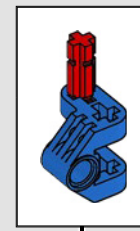

185

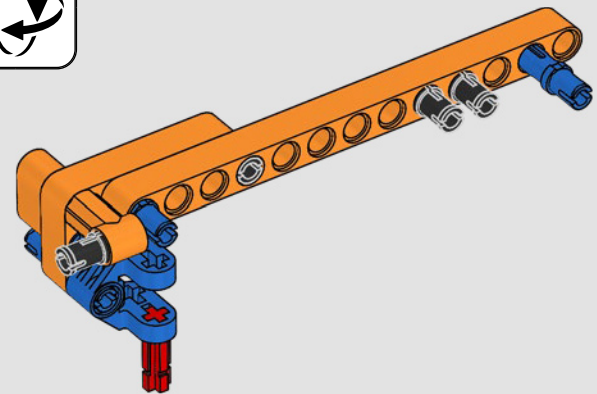

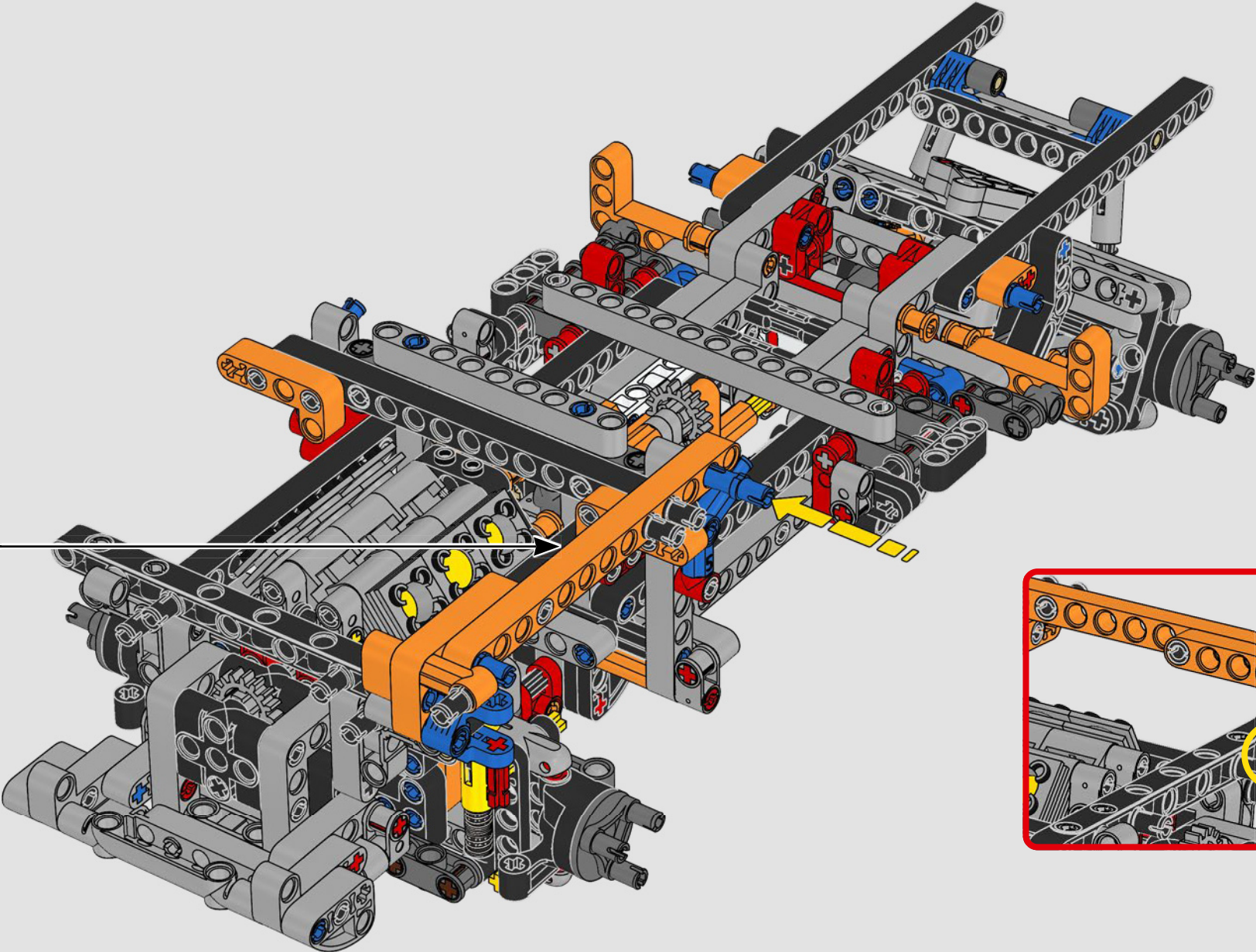

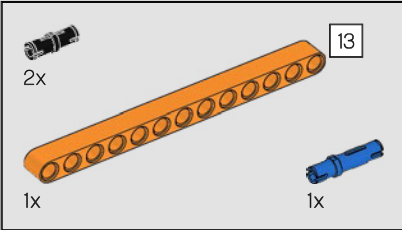
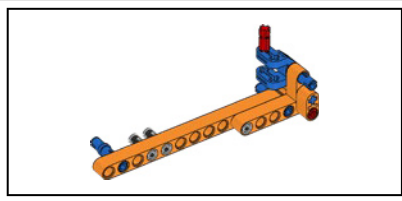

187

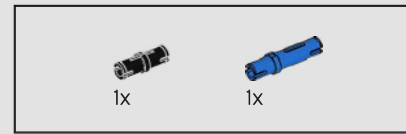
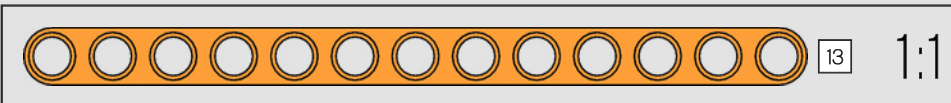
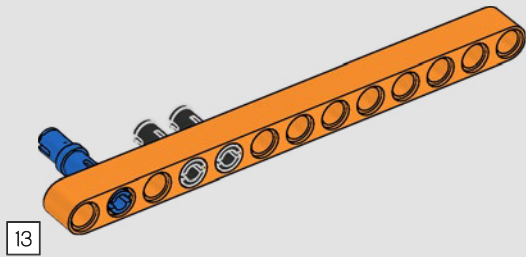

188

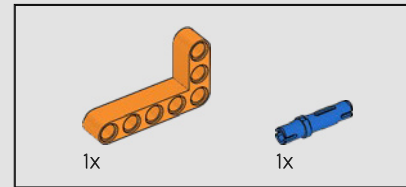
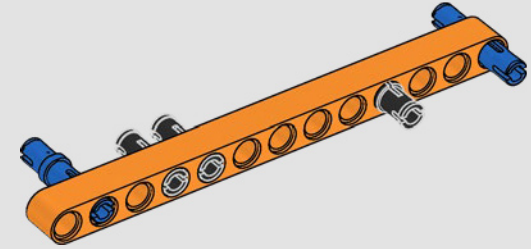

189

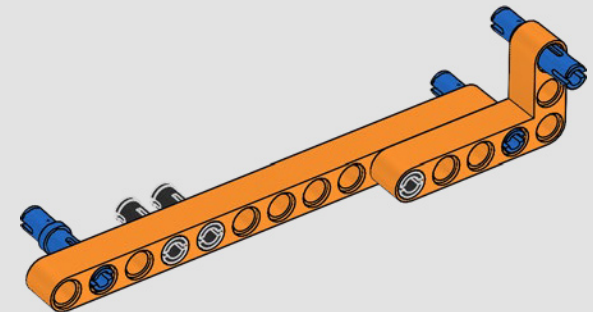

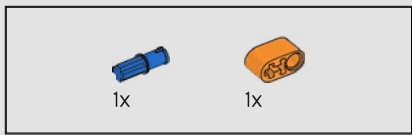

190

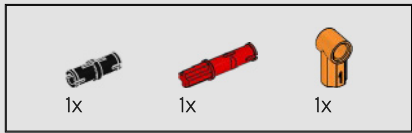
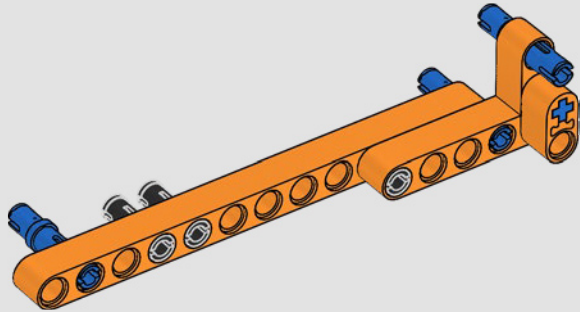

191

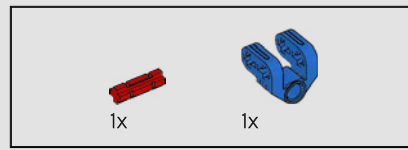
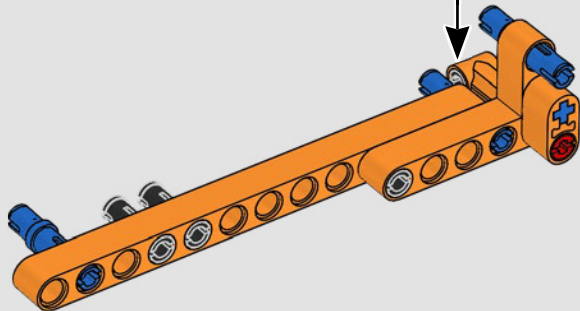
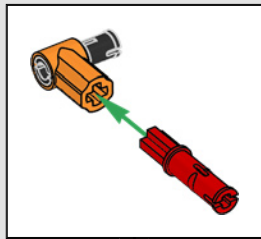

192

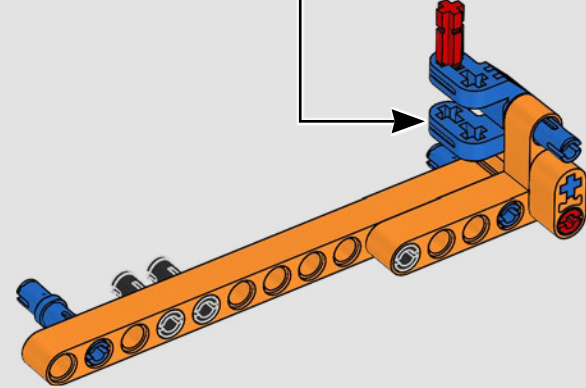
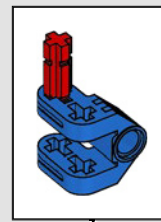

193

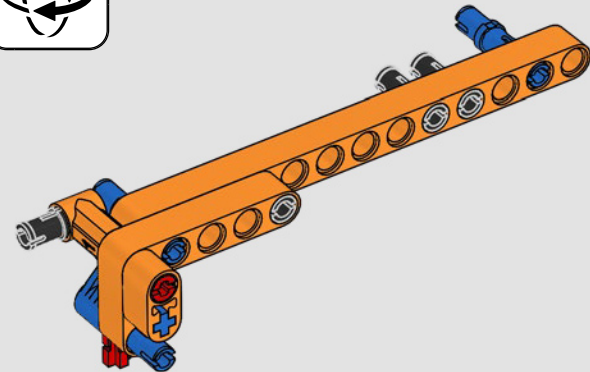
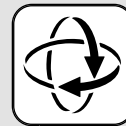

194

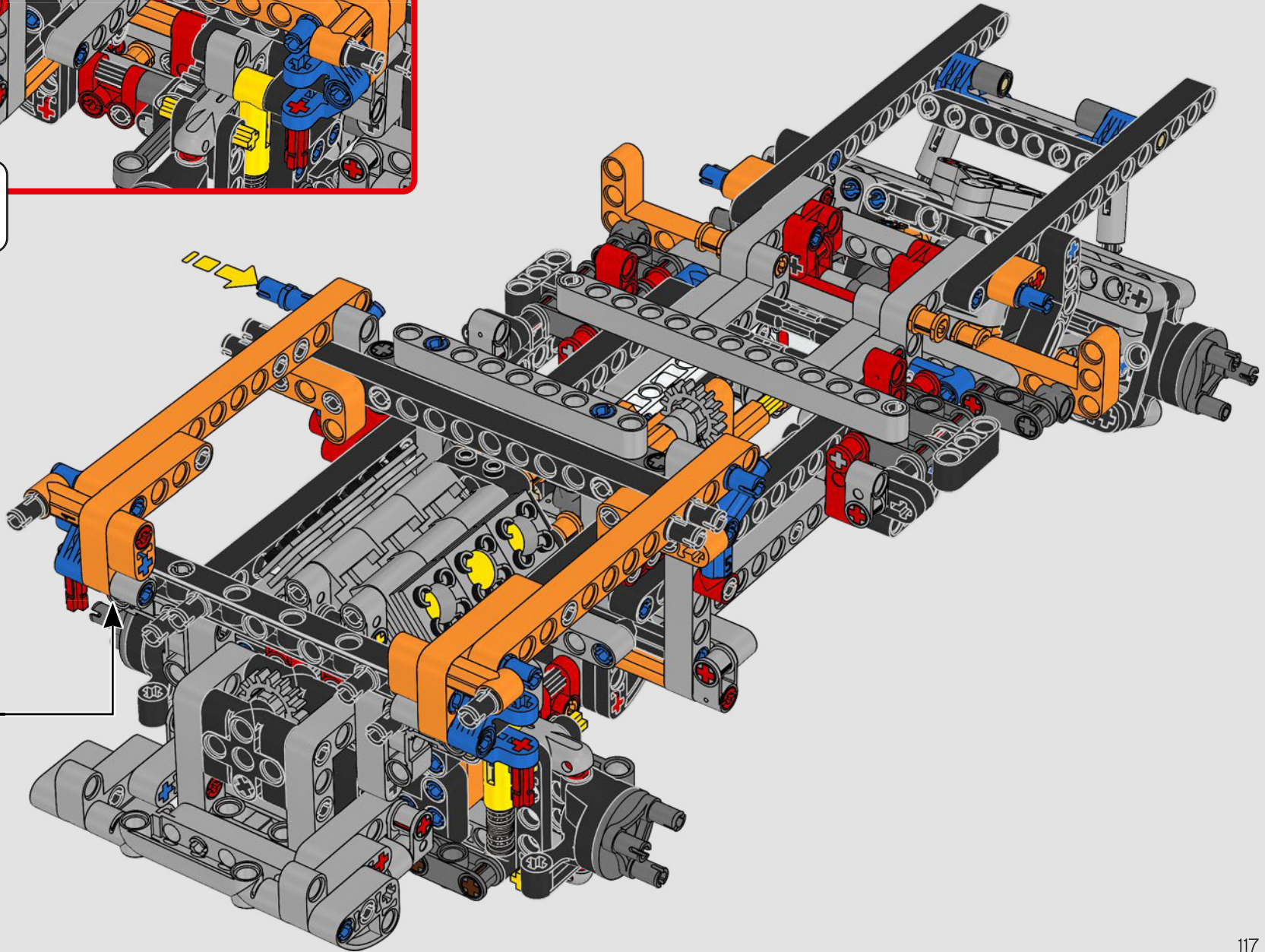
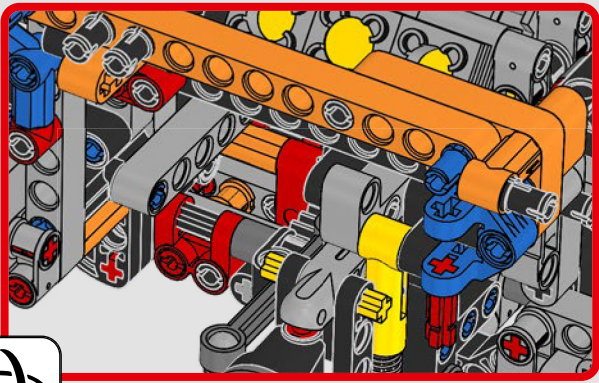

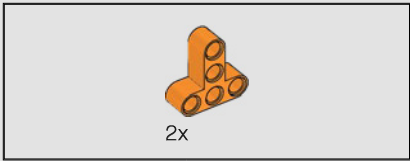

195

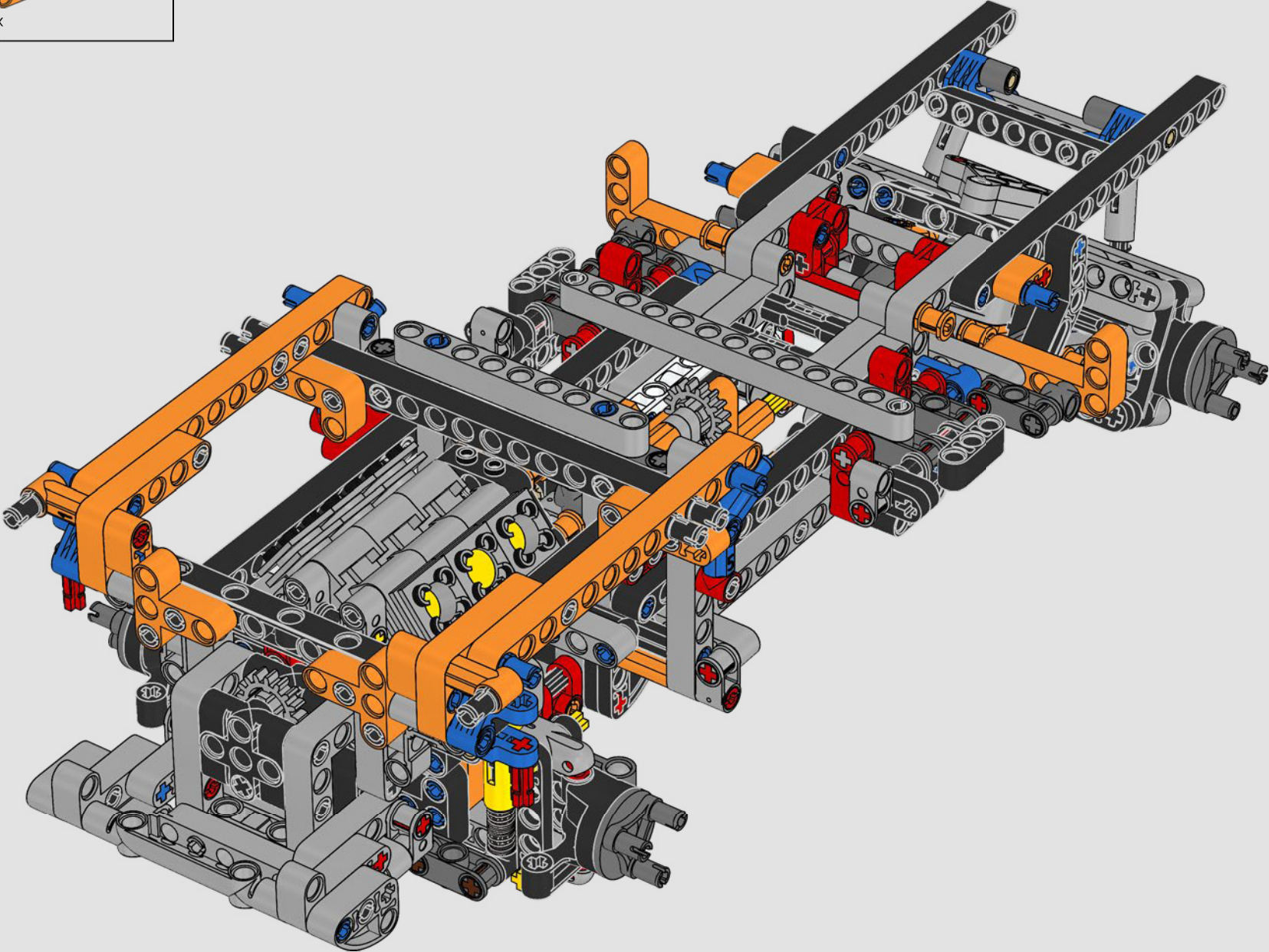



196

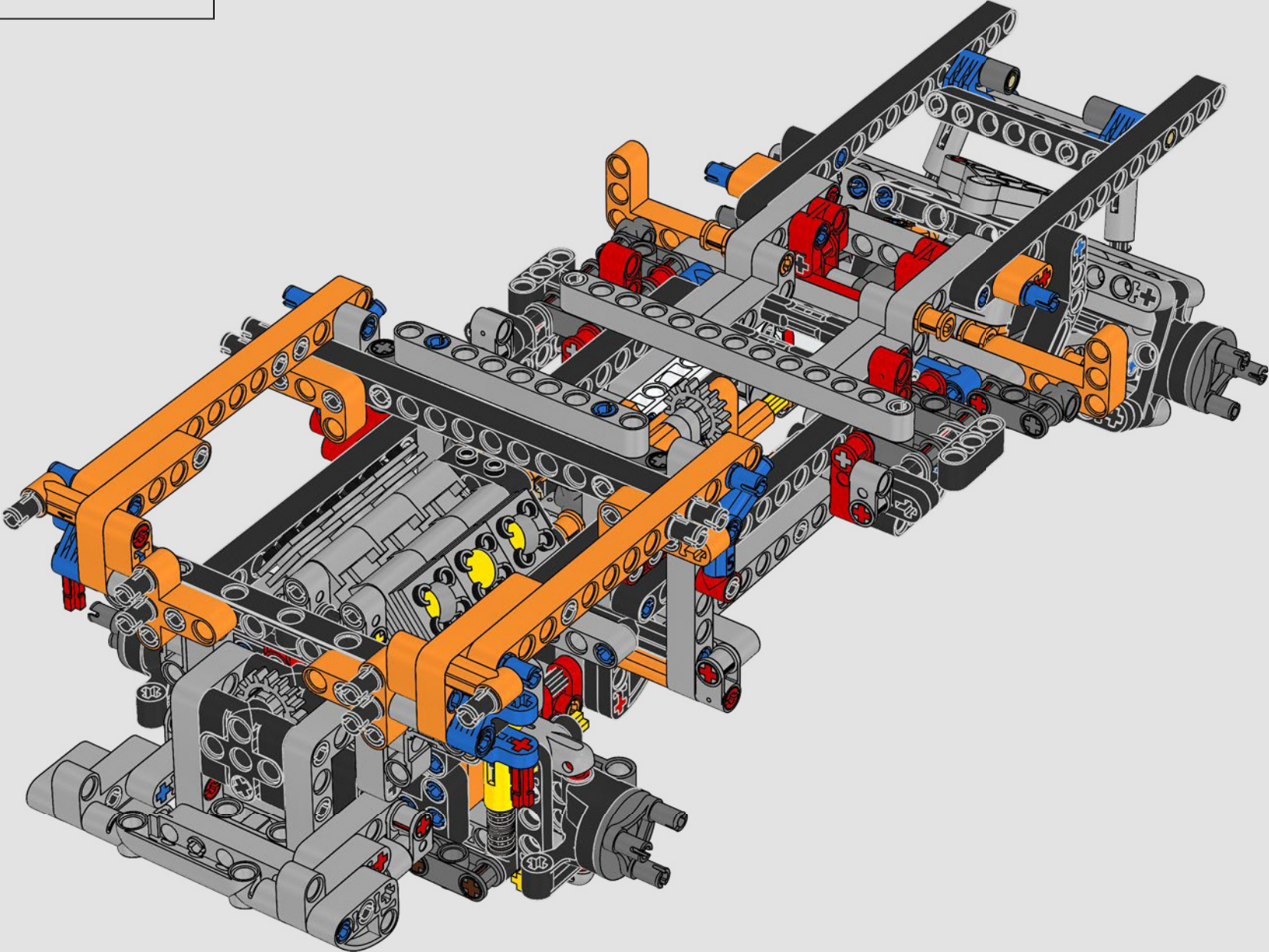

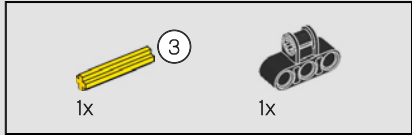
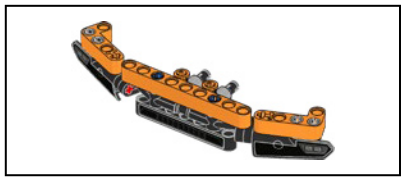

197

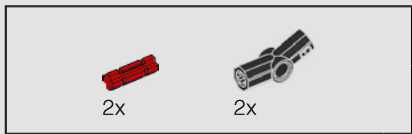

198

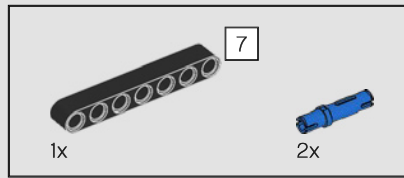
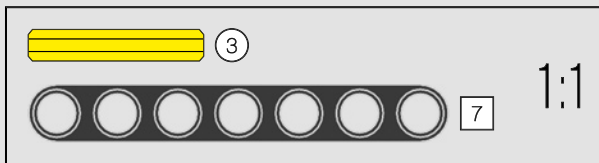
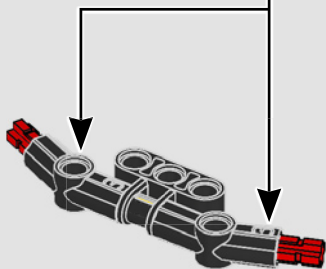
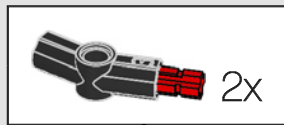

199

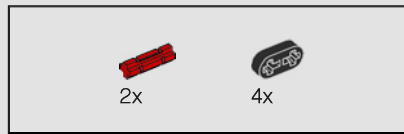
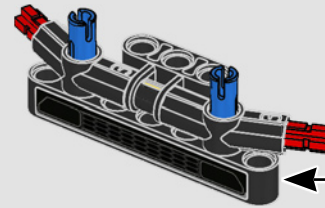
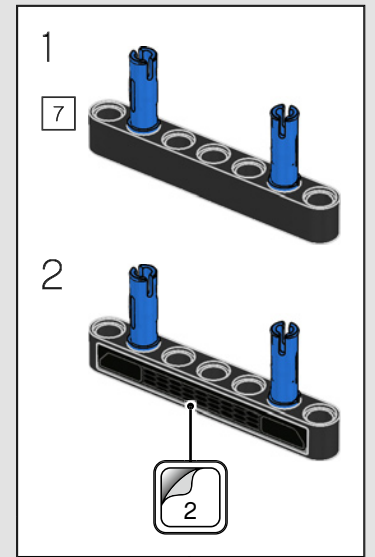

200

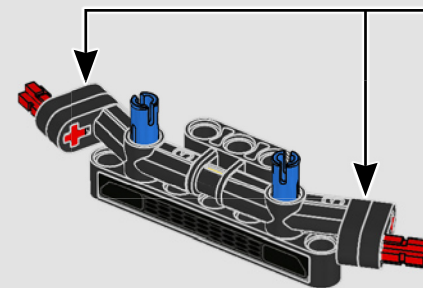
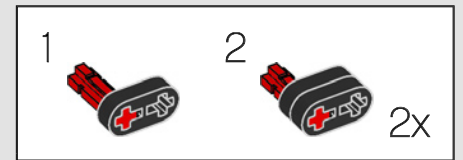



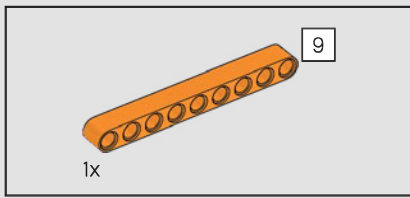

201

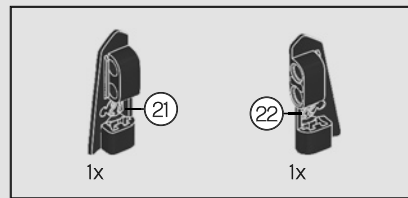
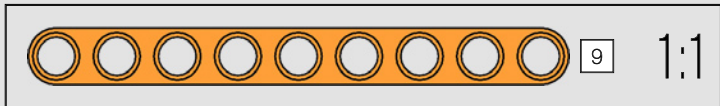
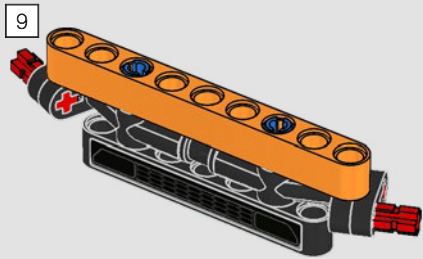

202

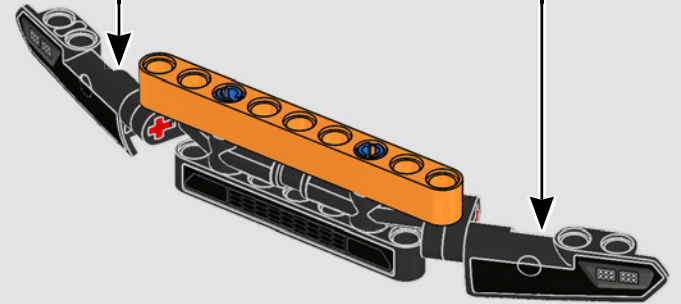
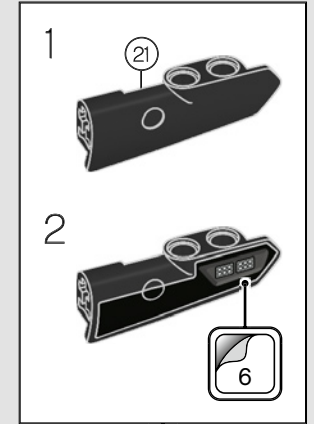
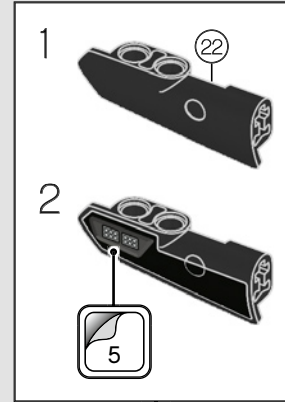



203

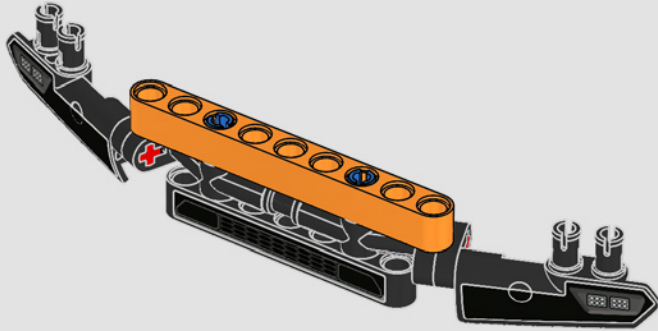

204

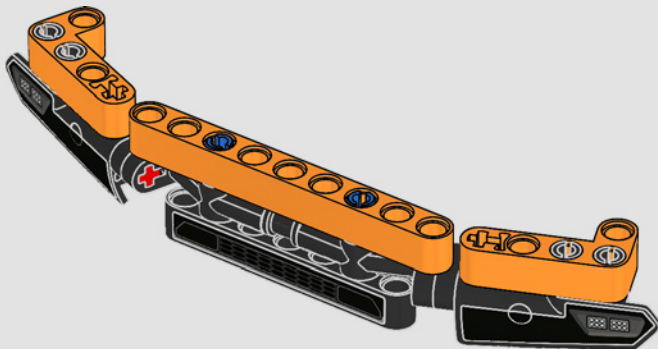

205

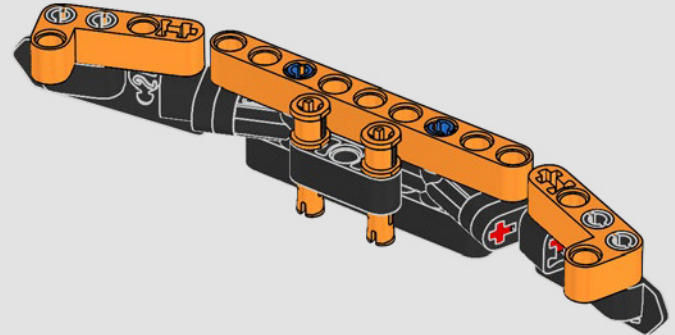
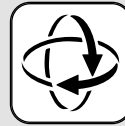

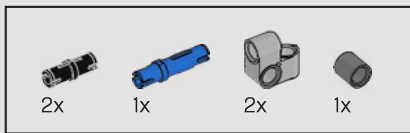

206

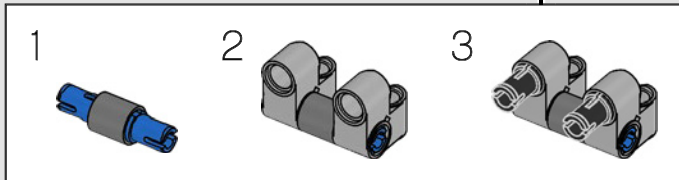
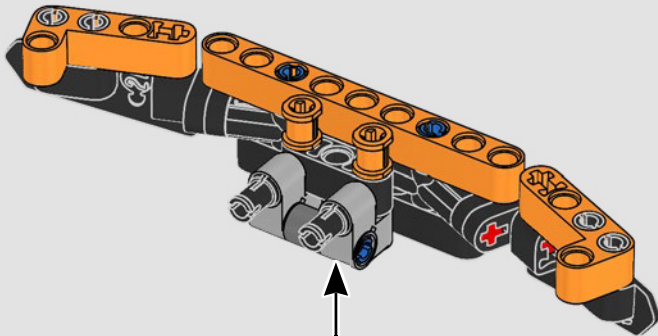

207

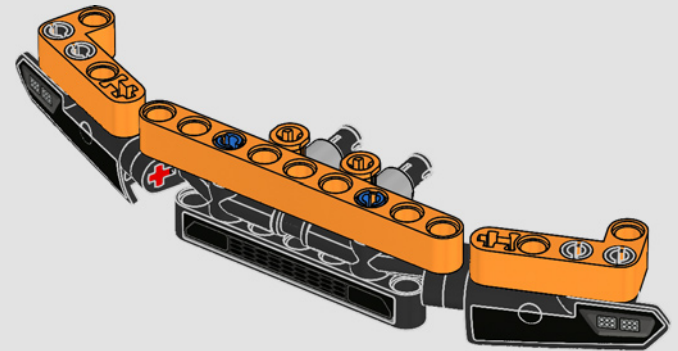

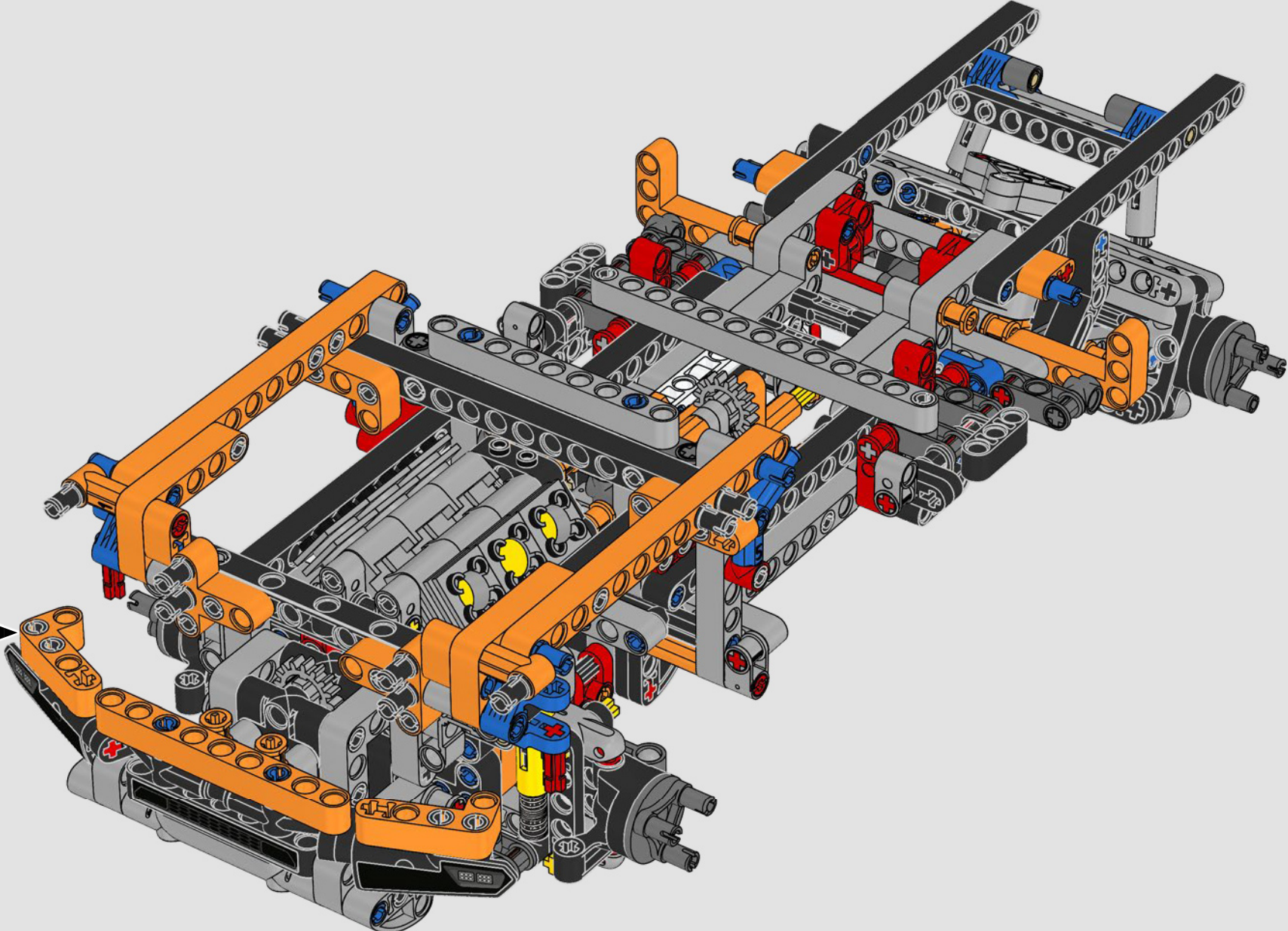

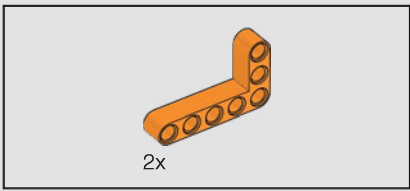

209

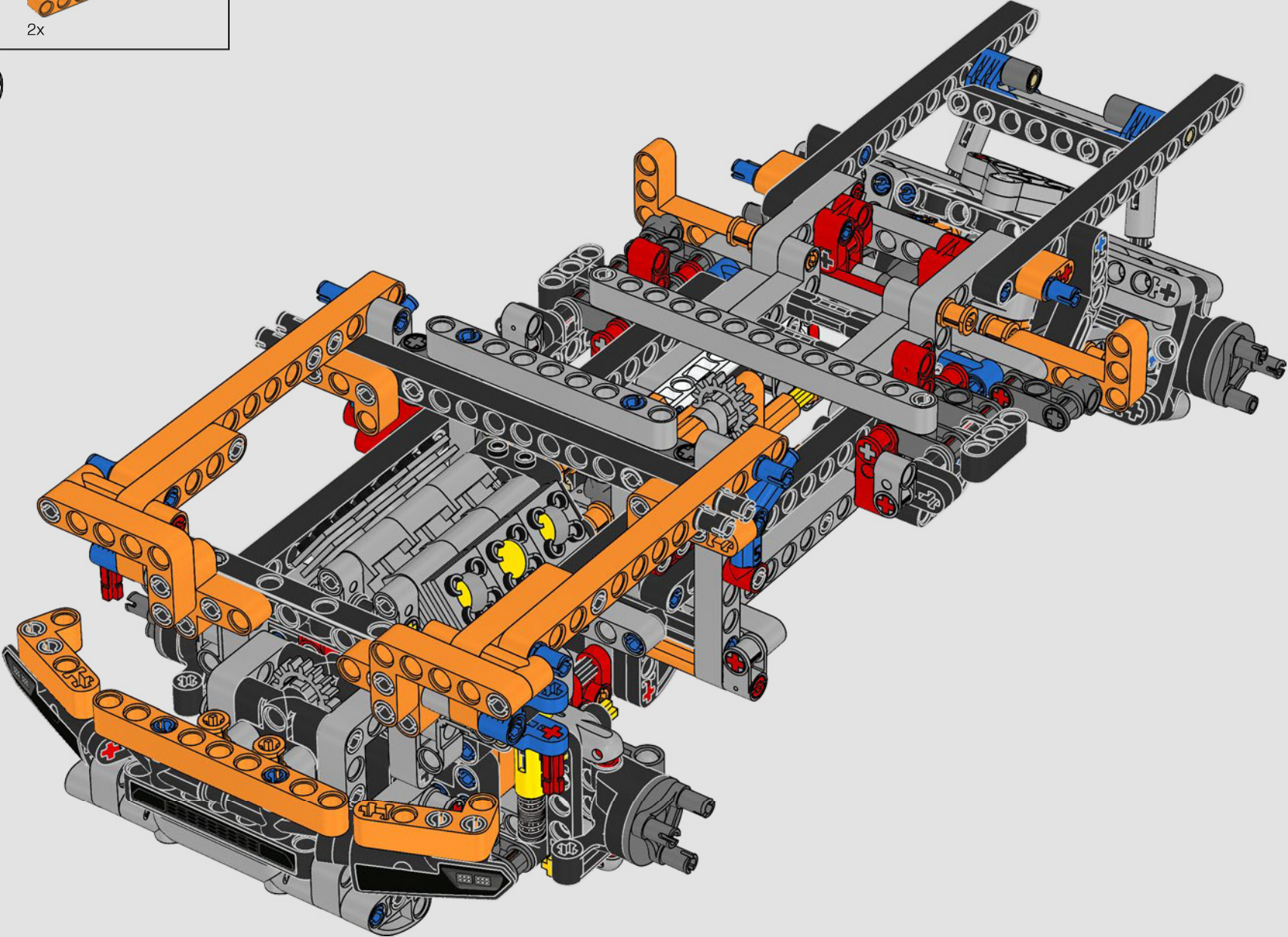

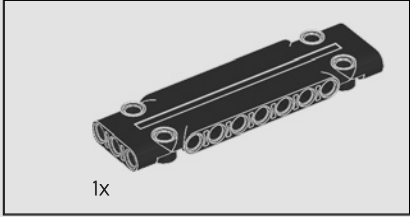
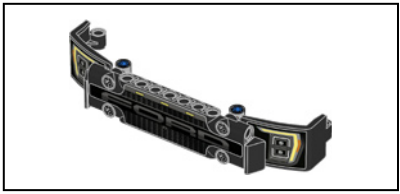

210

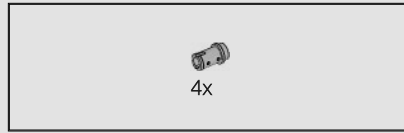
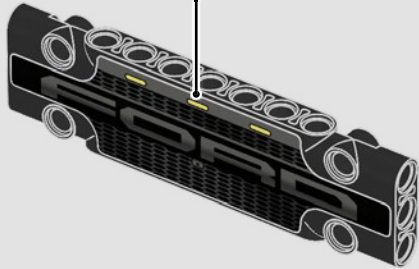

211

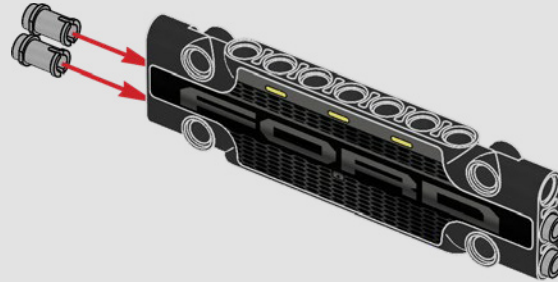

*Le Raptor est doté de sa propre calandre, qui remplace l'emblématique ovale bleu de Ford par une large inscription « FORD ».*

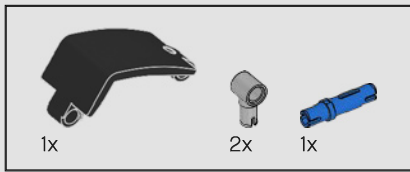

212

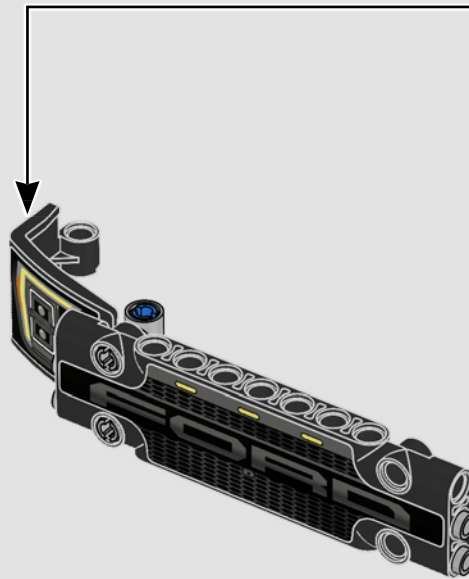
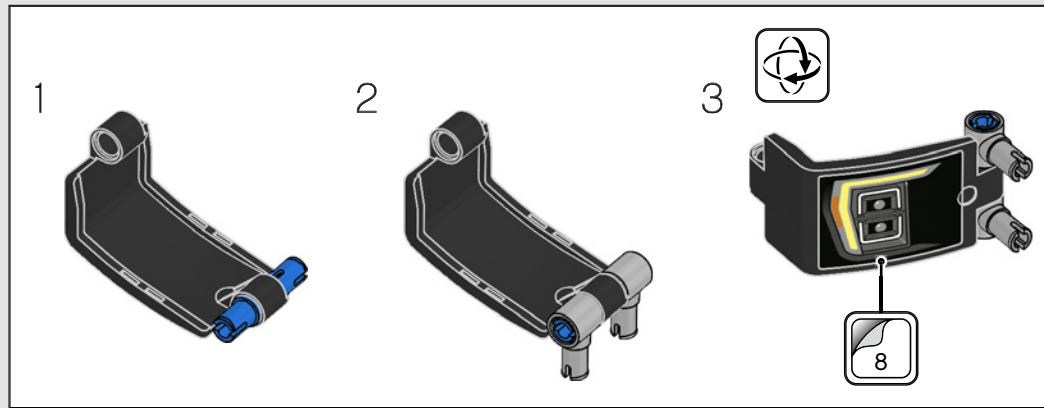

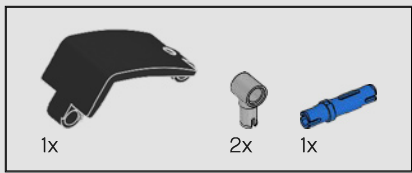

213

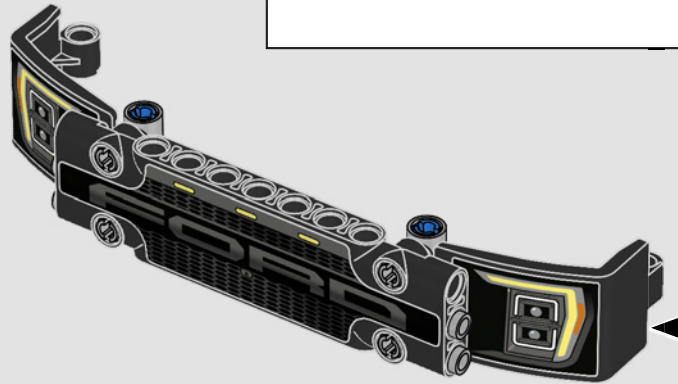
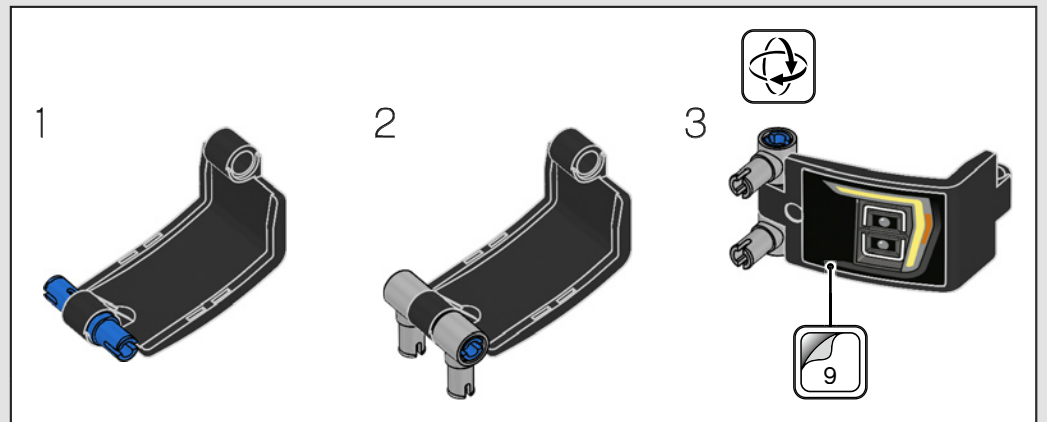

214

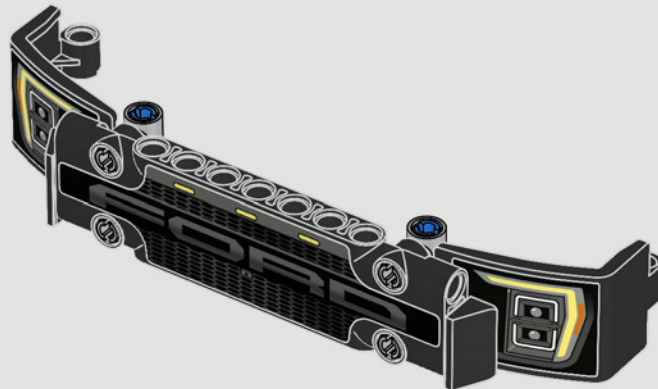



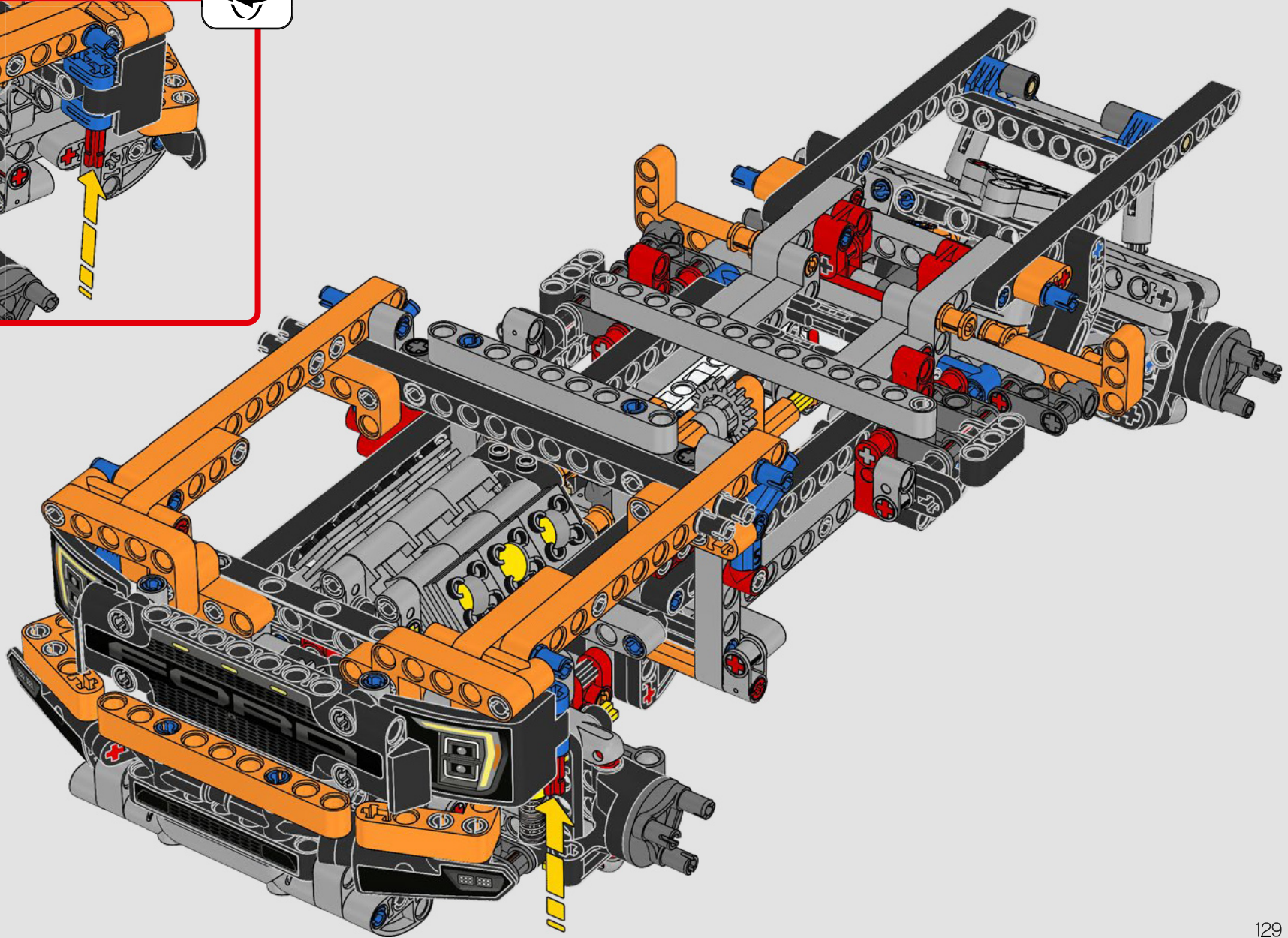
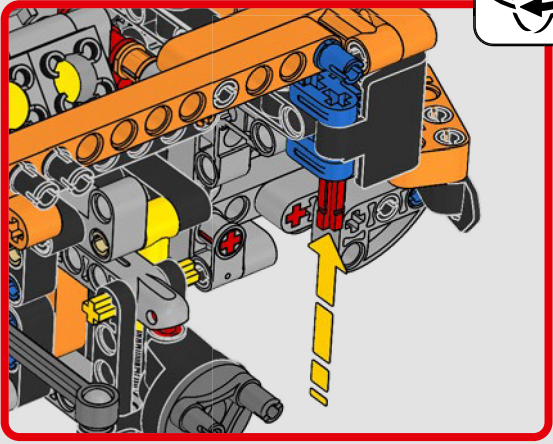

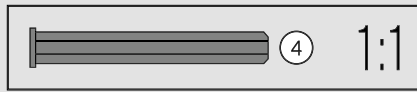
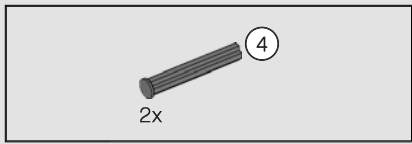

216

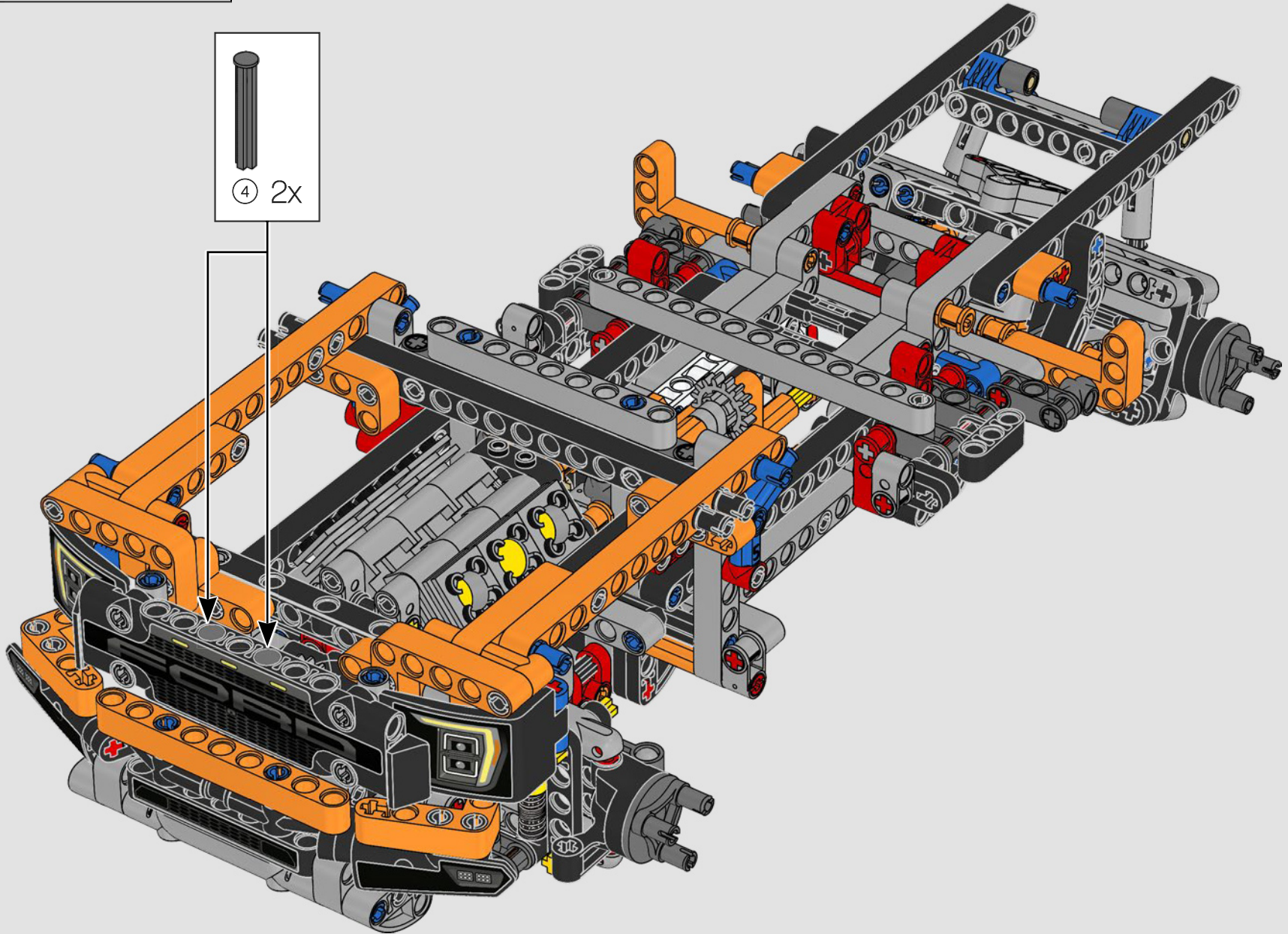
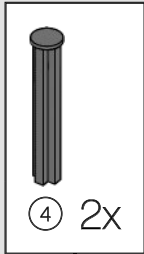

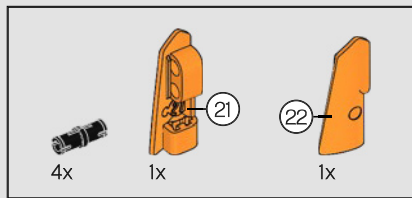

217

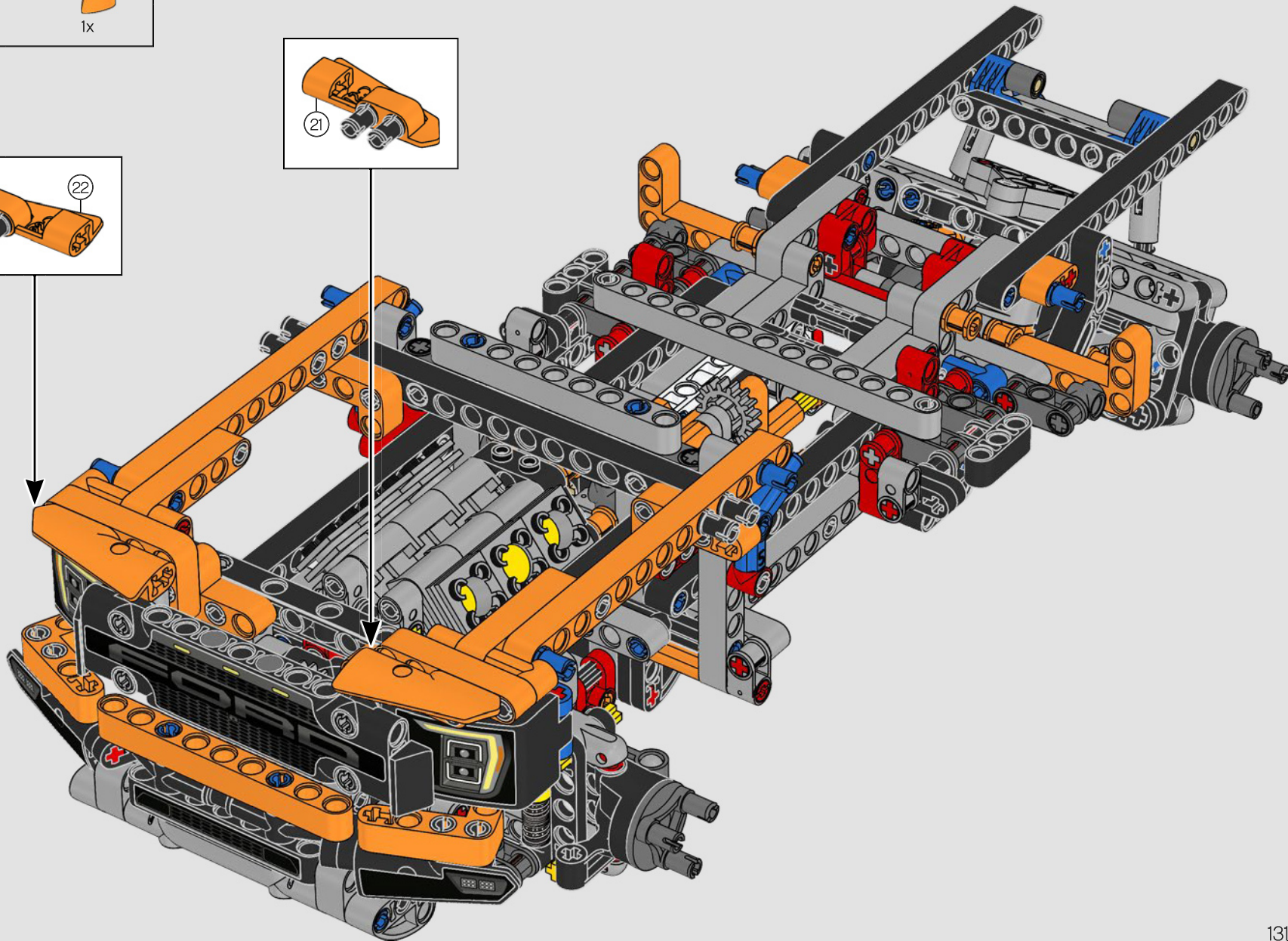
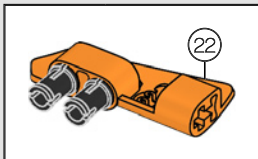
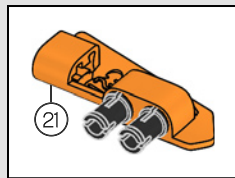

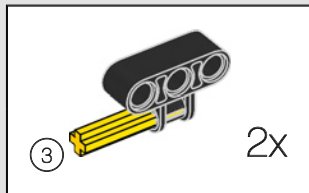
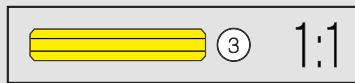
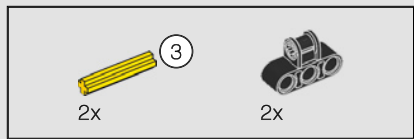

218

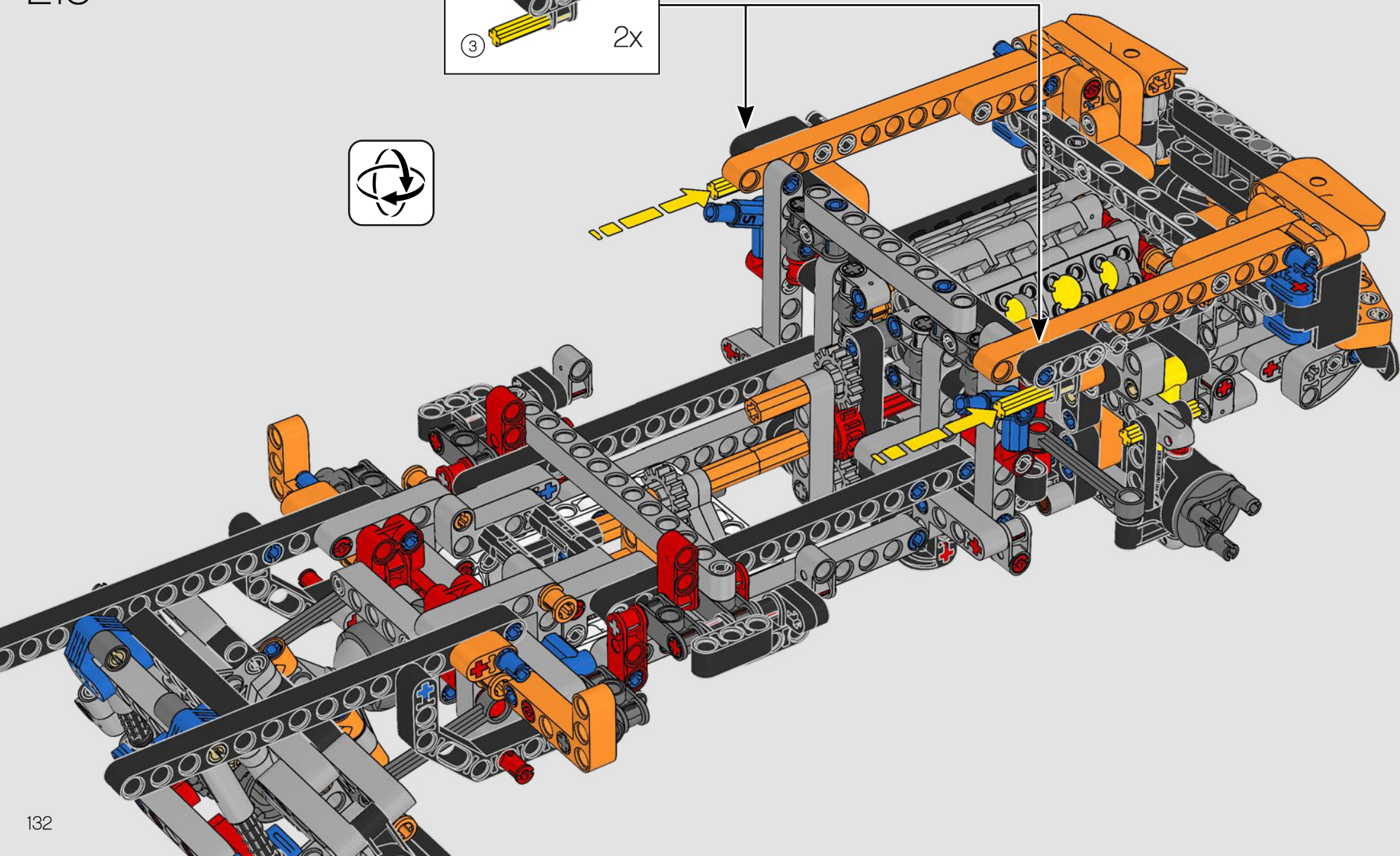
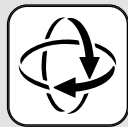

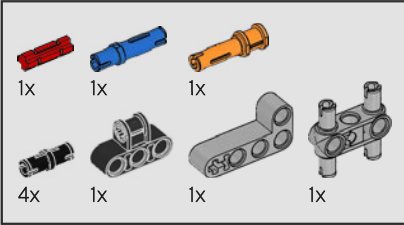
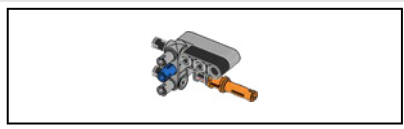

219

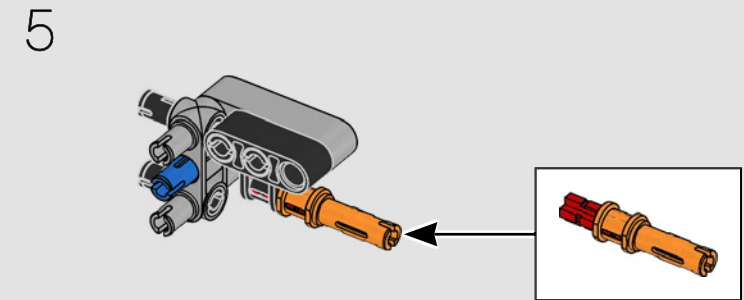
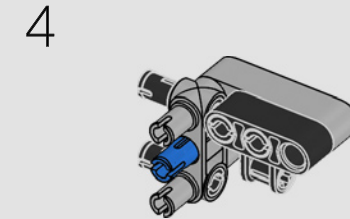
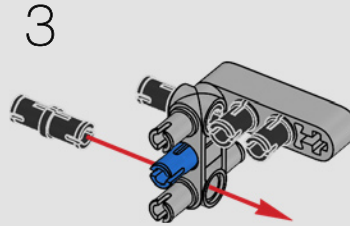
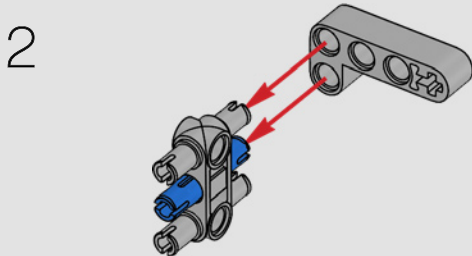
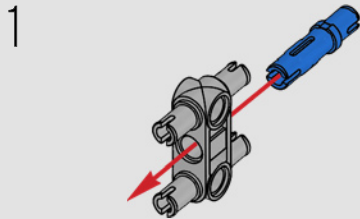

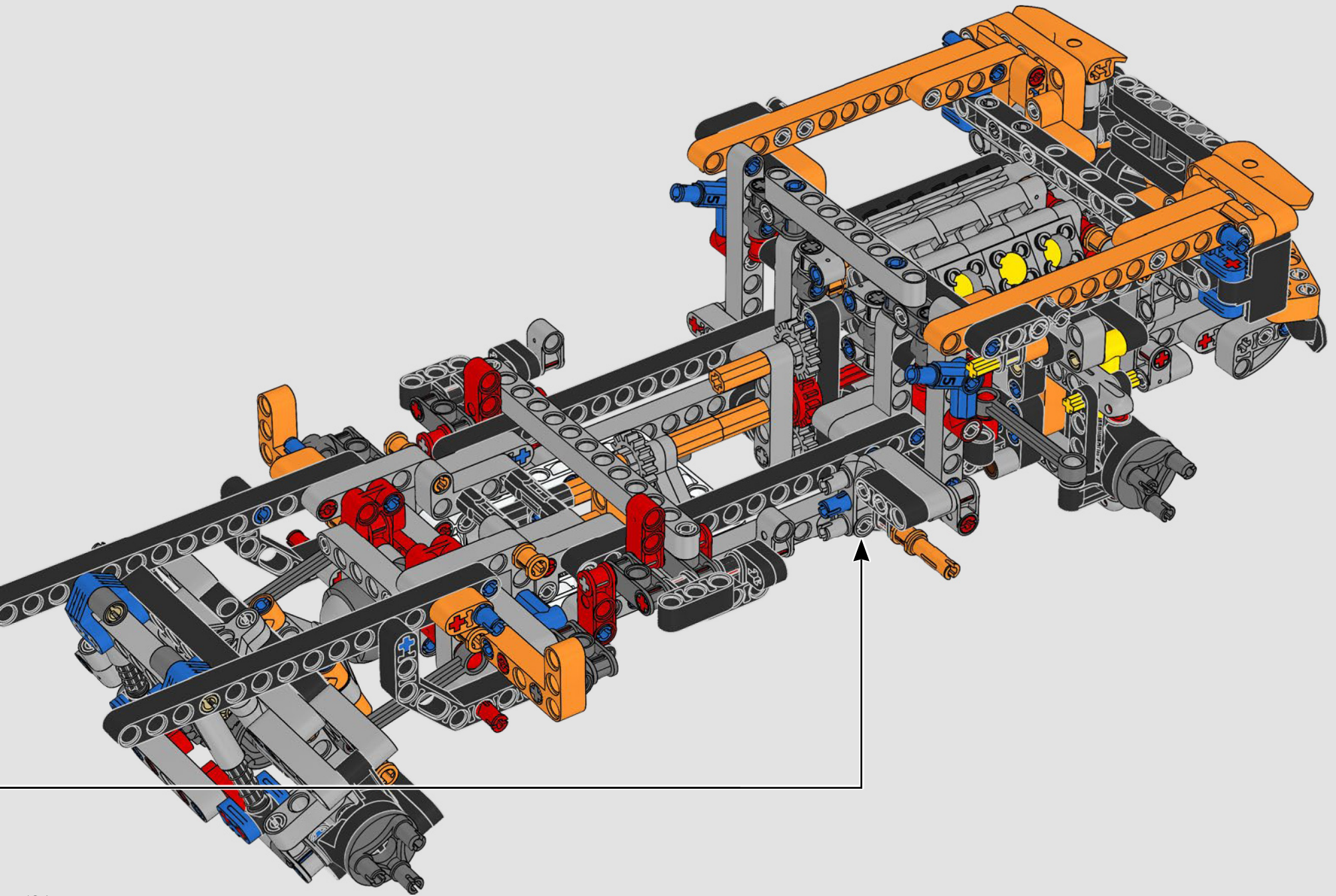

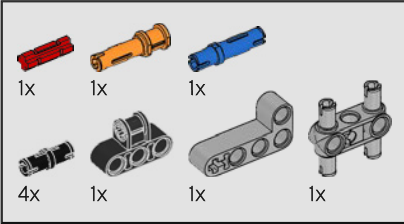
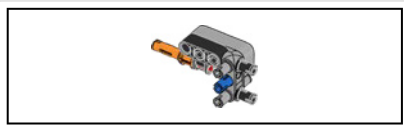

220

1

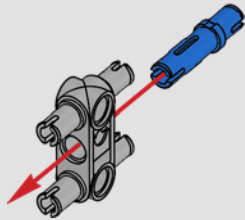

2

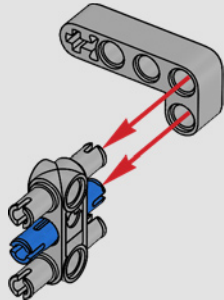

3

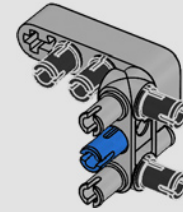

4

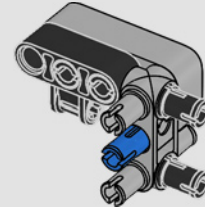

5

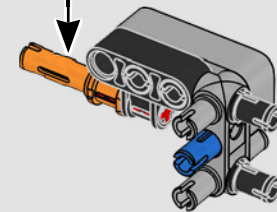
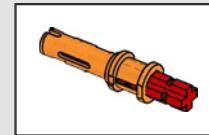

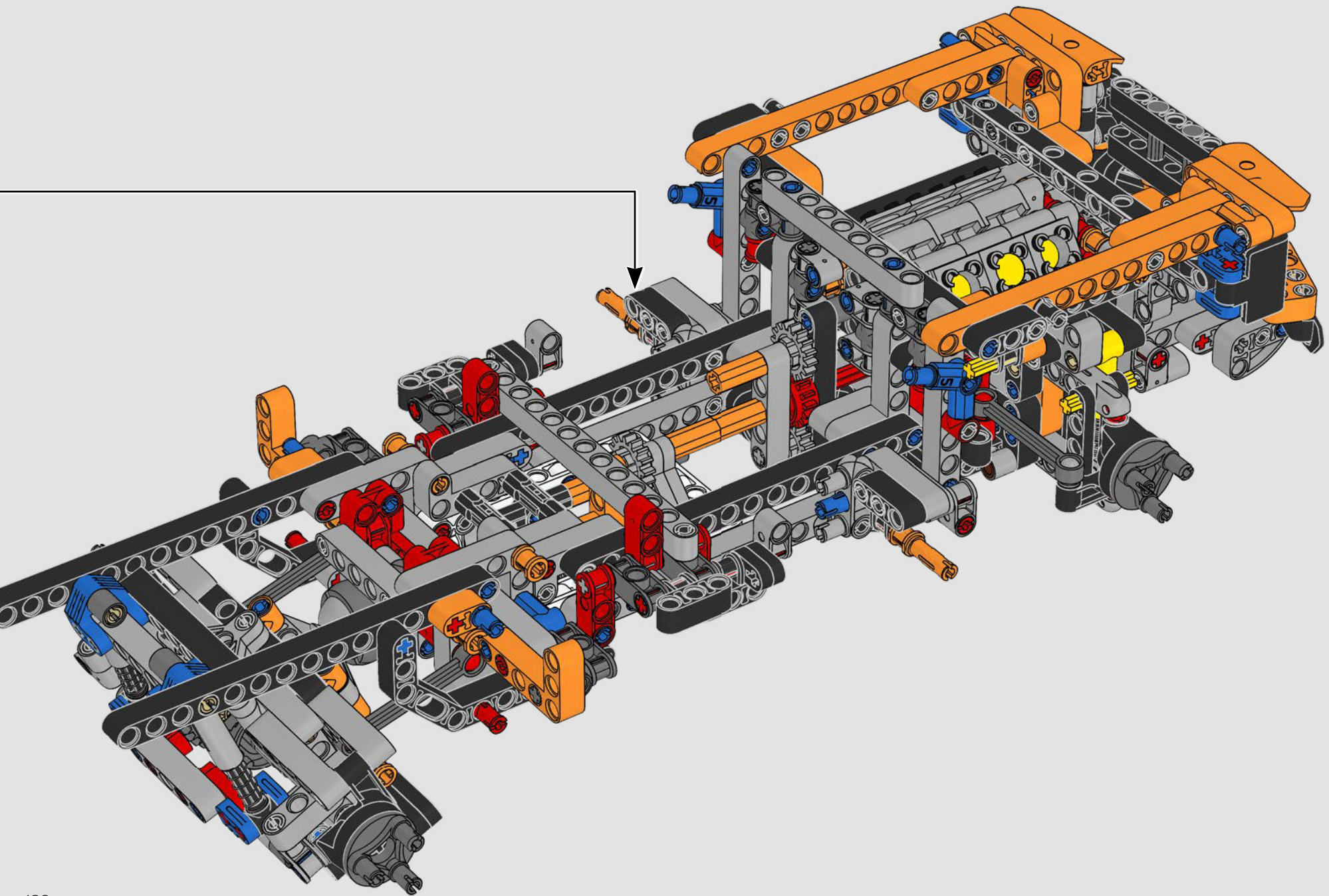



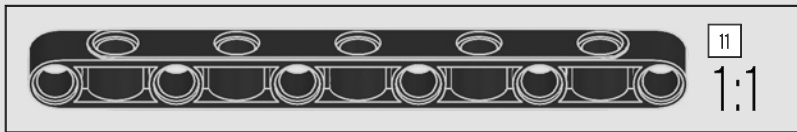
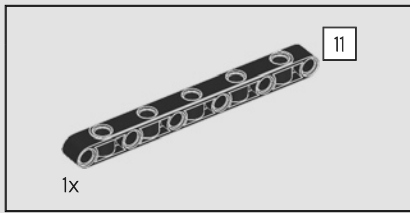

221

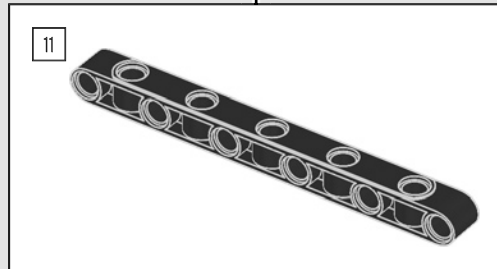
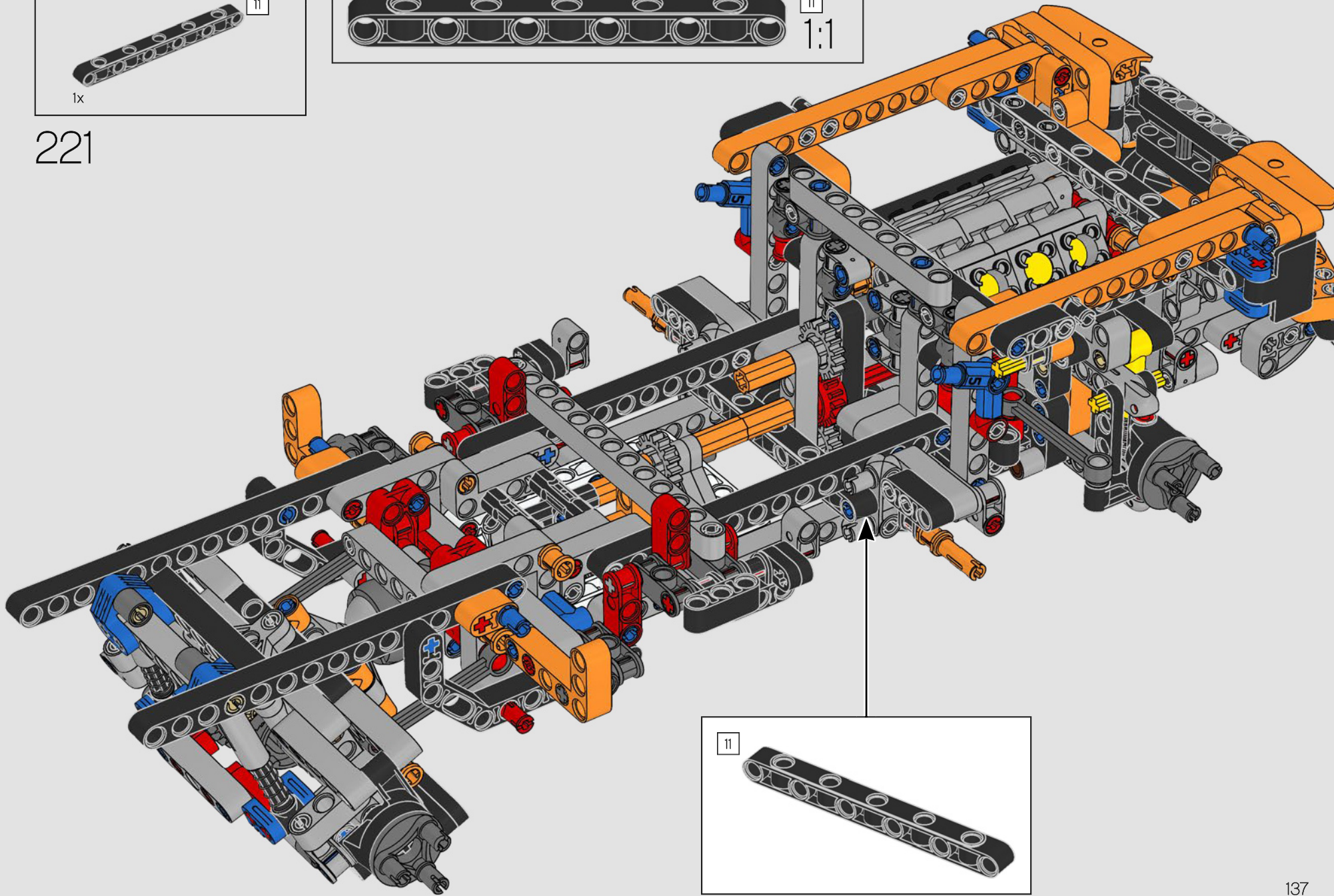

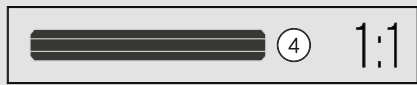
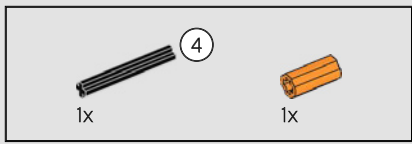

222

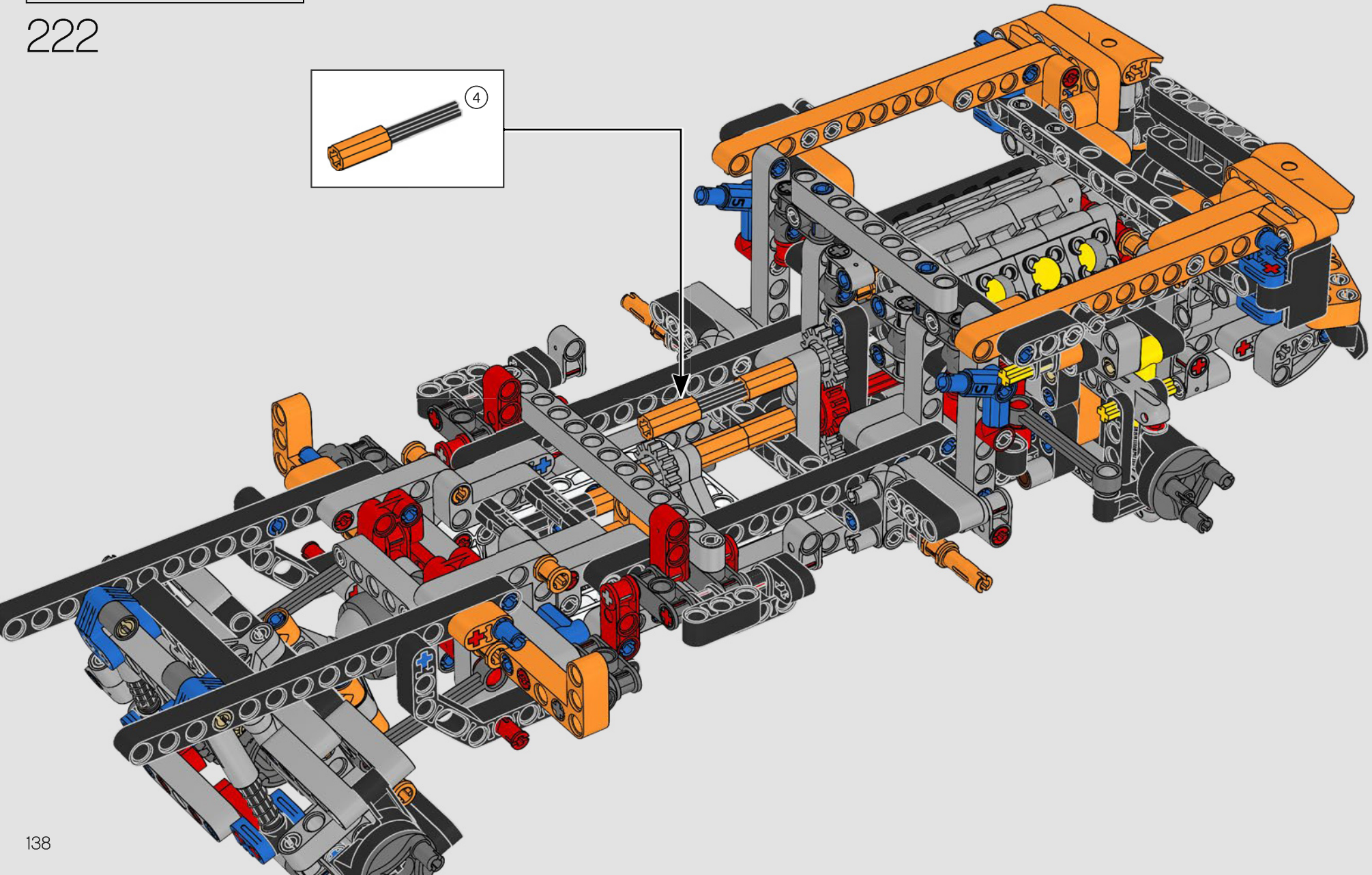
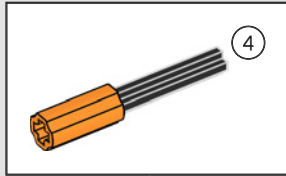

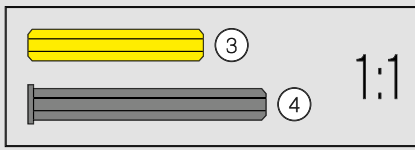
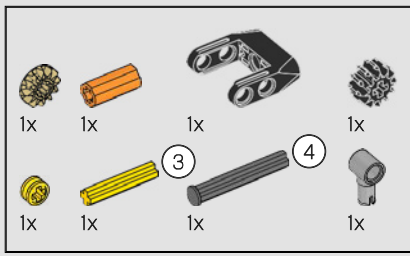

223

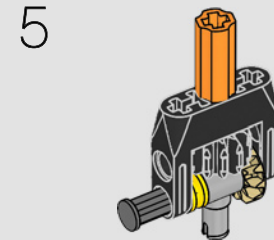
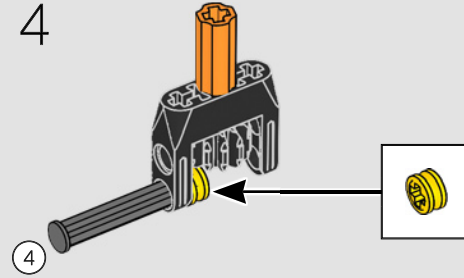
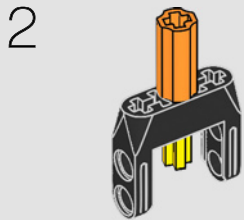
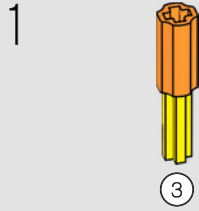

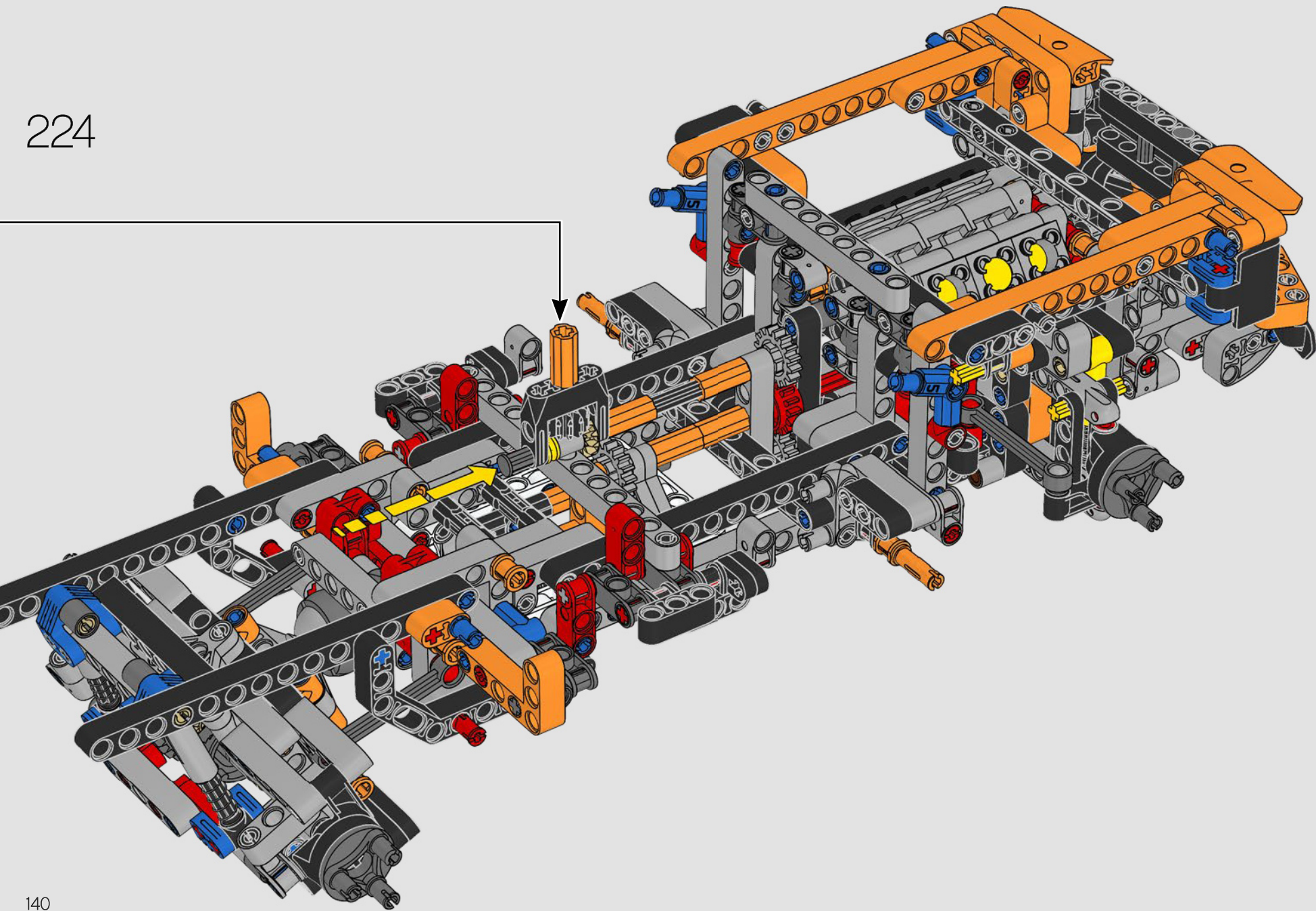

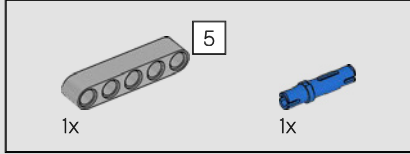
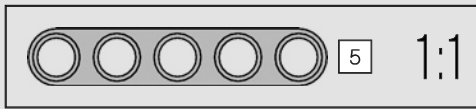
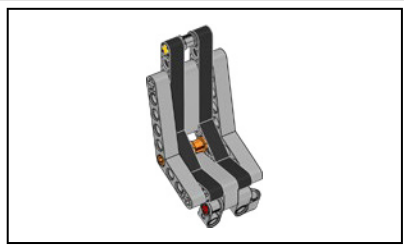

225

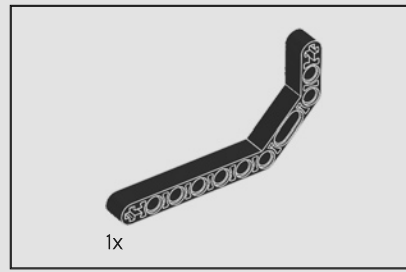
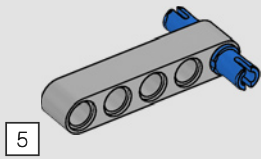

226

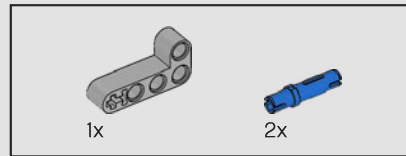
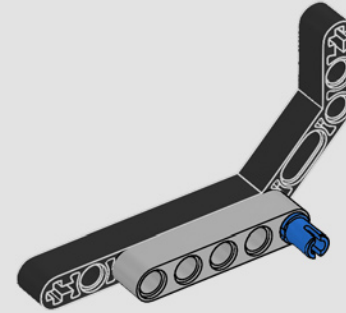

227

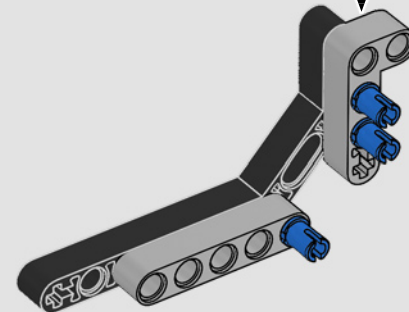
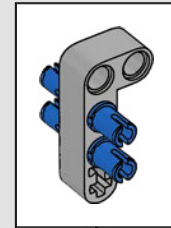

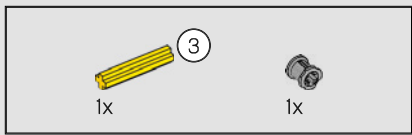

228

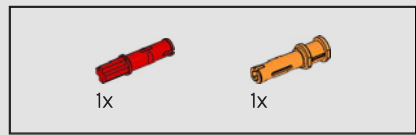
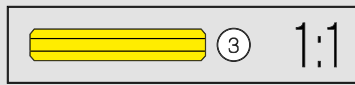
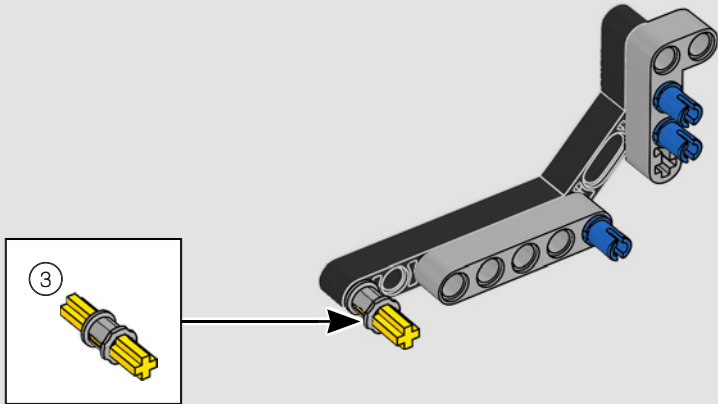

229

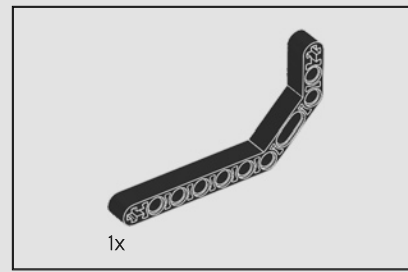
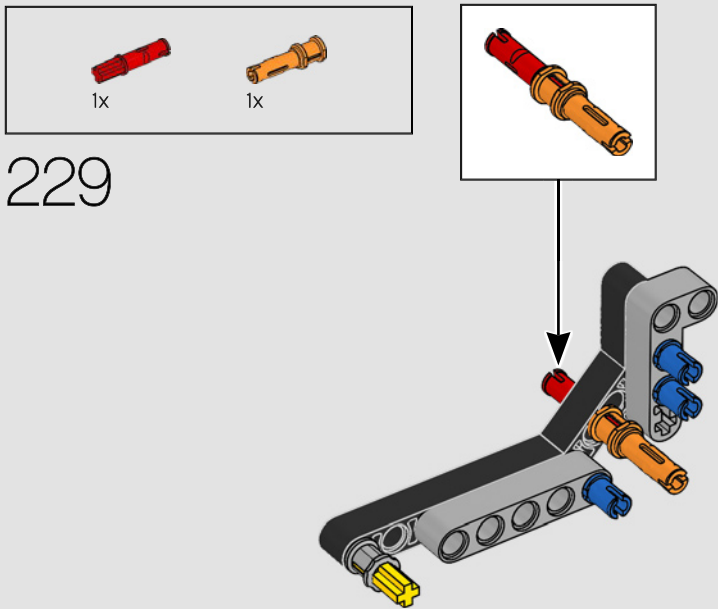

230

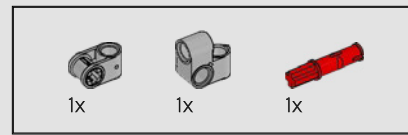
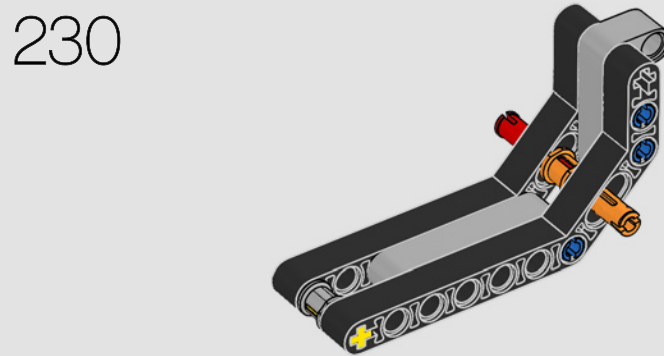

231

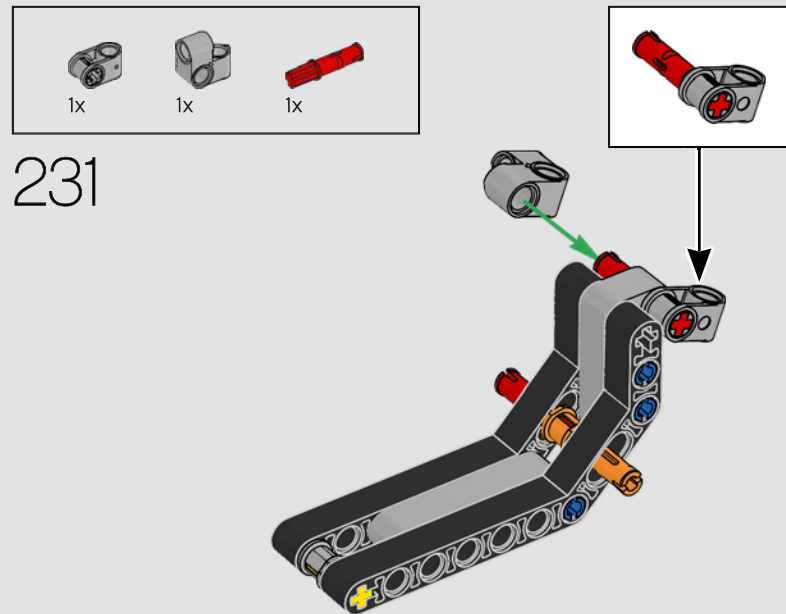

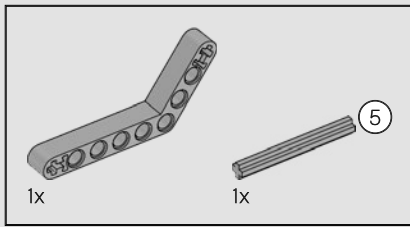

232

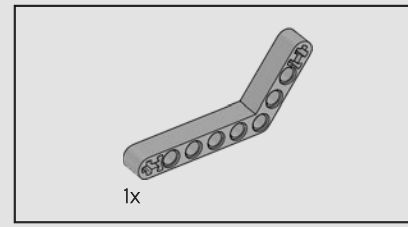
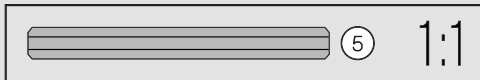
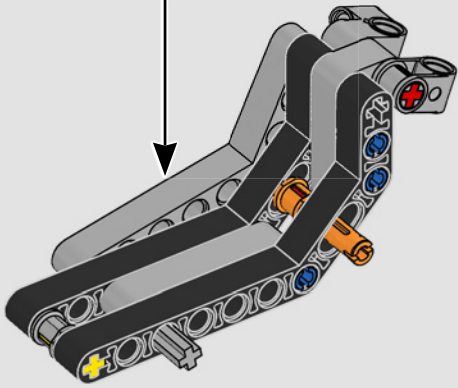
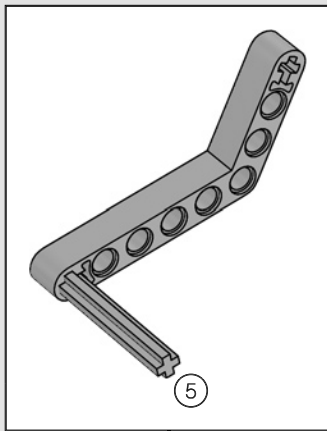

233

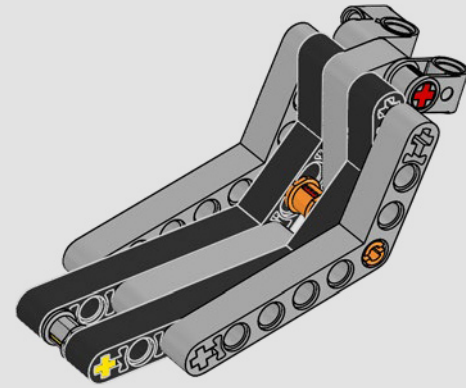

234

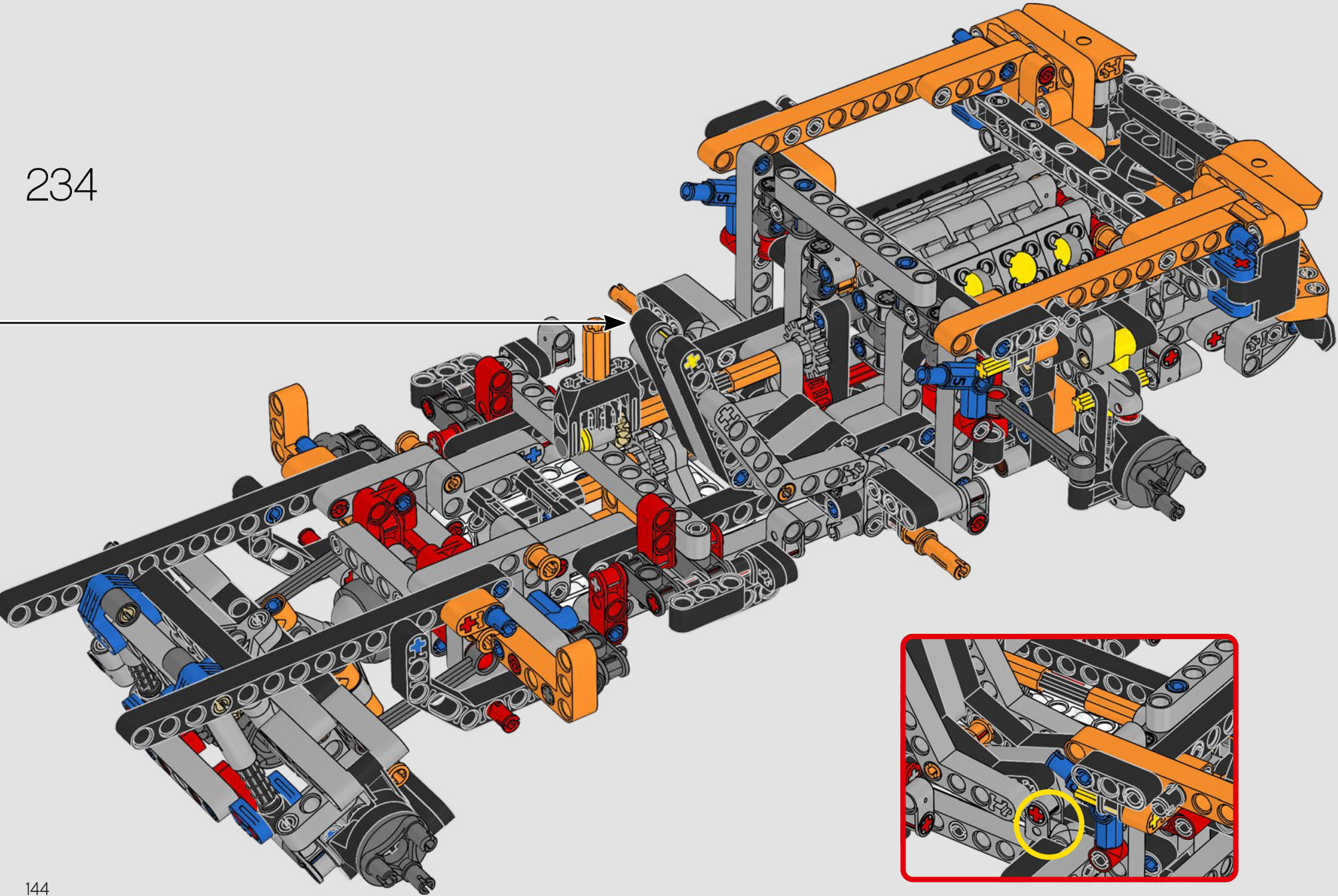



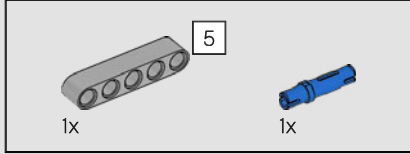
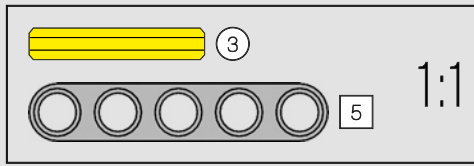
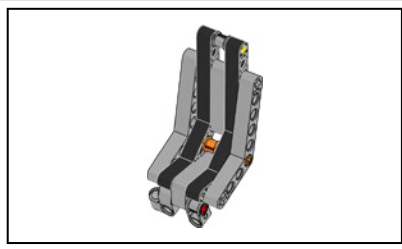

235

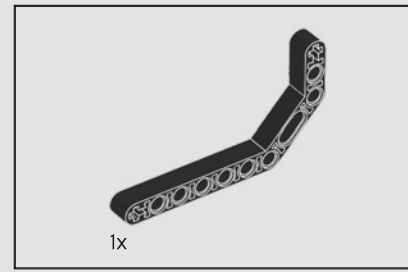
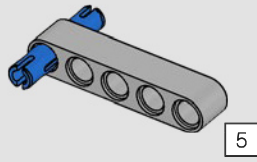

236

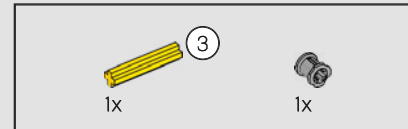
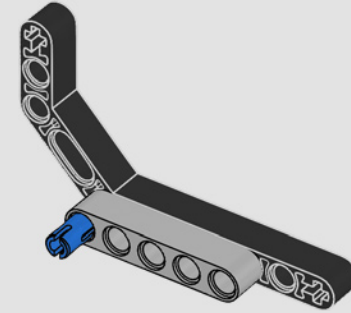

237

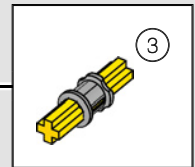
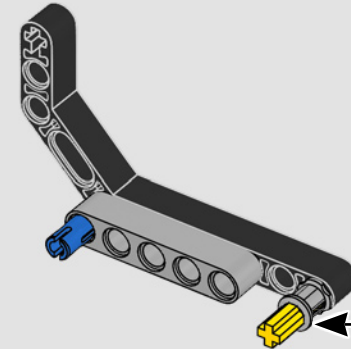

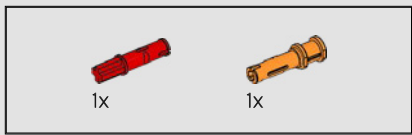

238

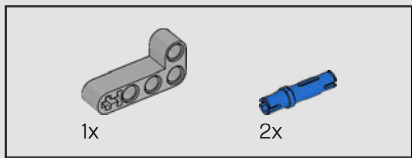
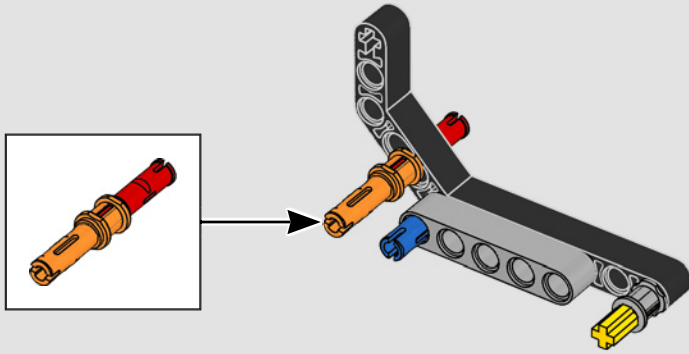

239

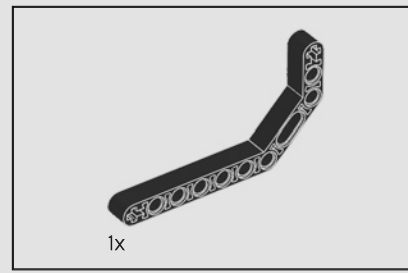
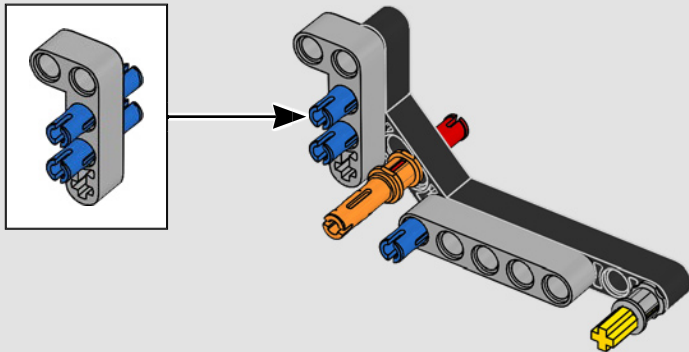

240

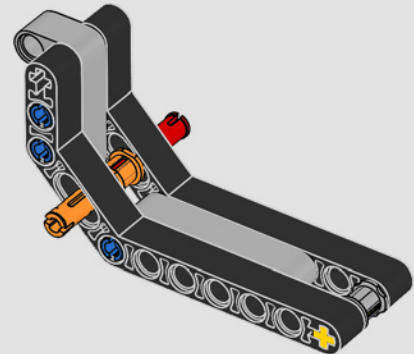

241

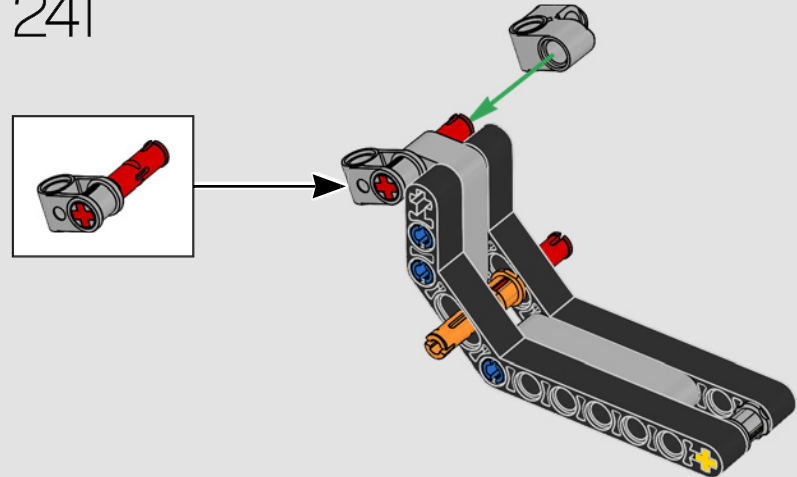

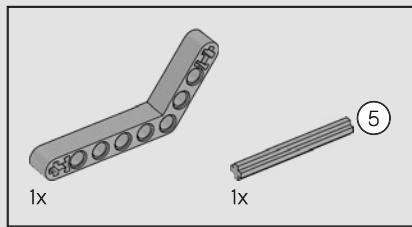

242

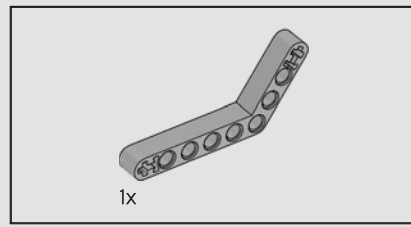
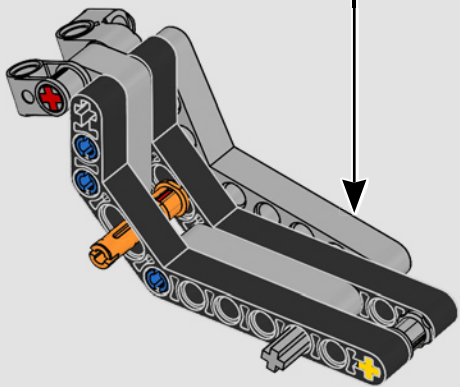
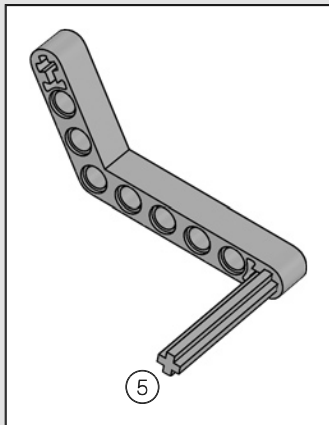
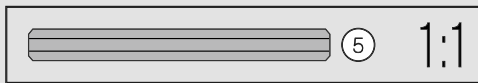

243

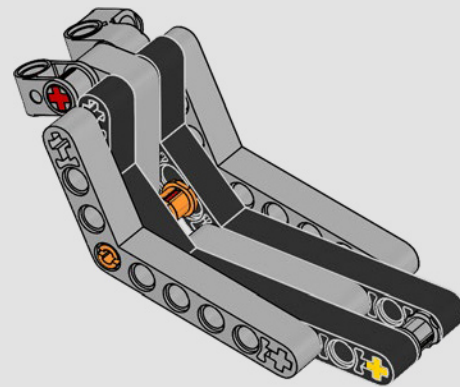

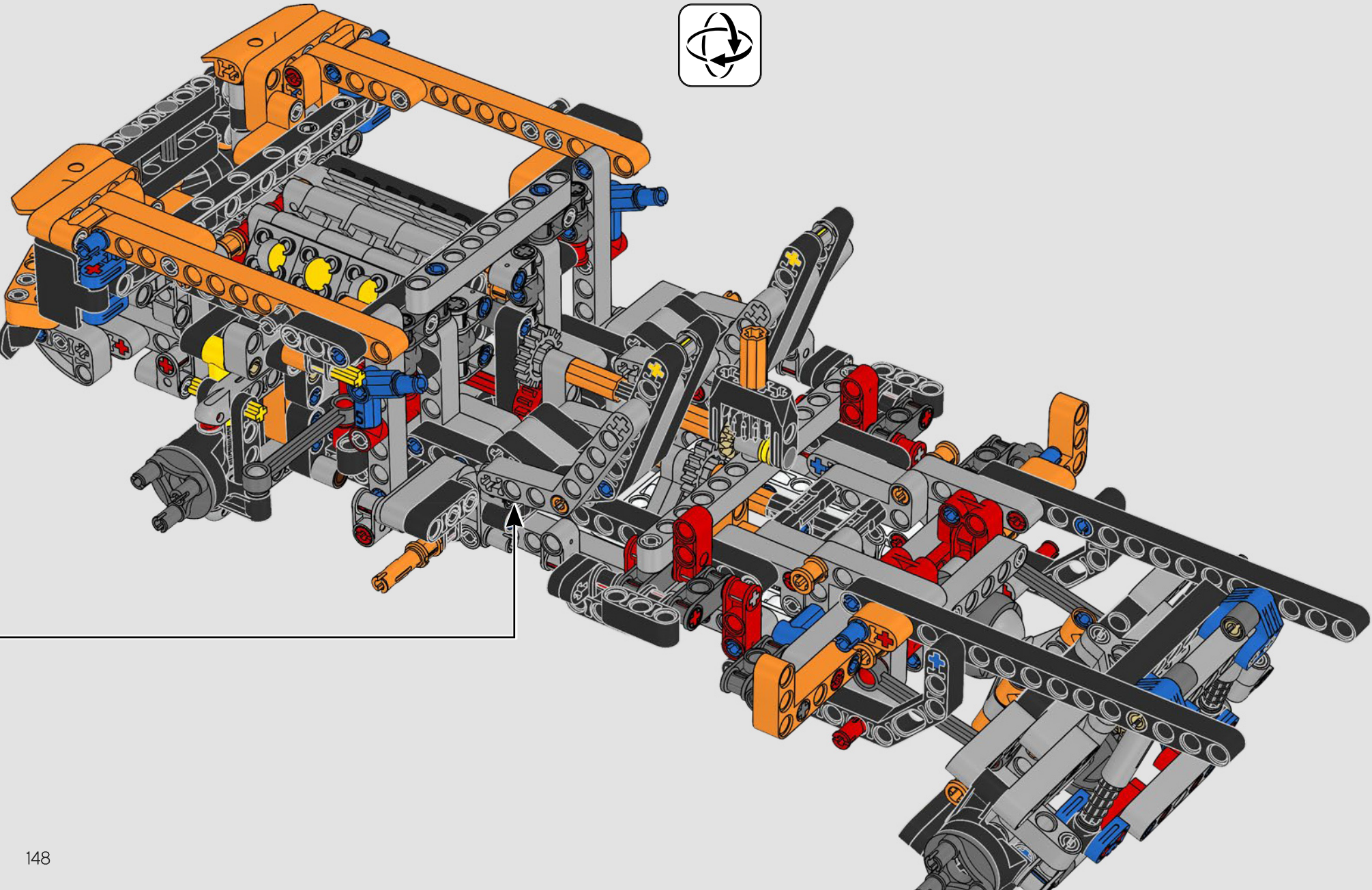
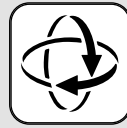

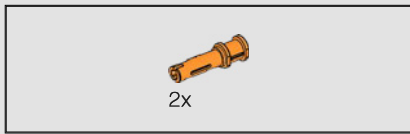

*Entièrement repensé, le Raptor 2021 F-150 présente des capacités renforcées avec une toute nouvelle suspension arrière à cinq bras assurant une meilleure position de l'essieu sur les terrains accidentés.*

245

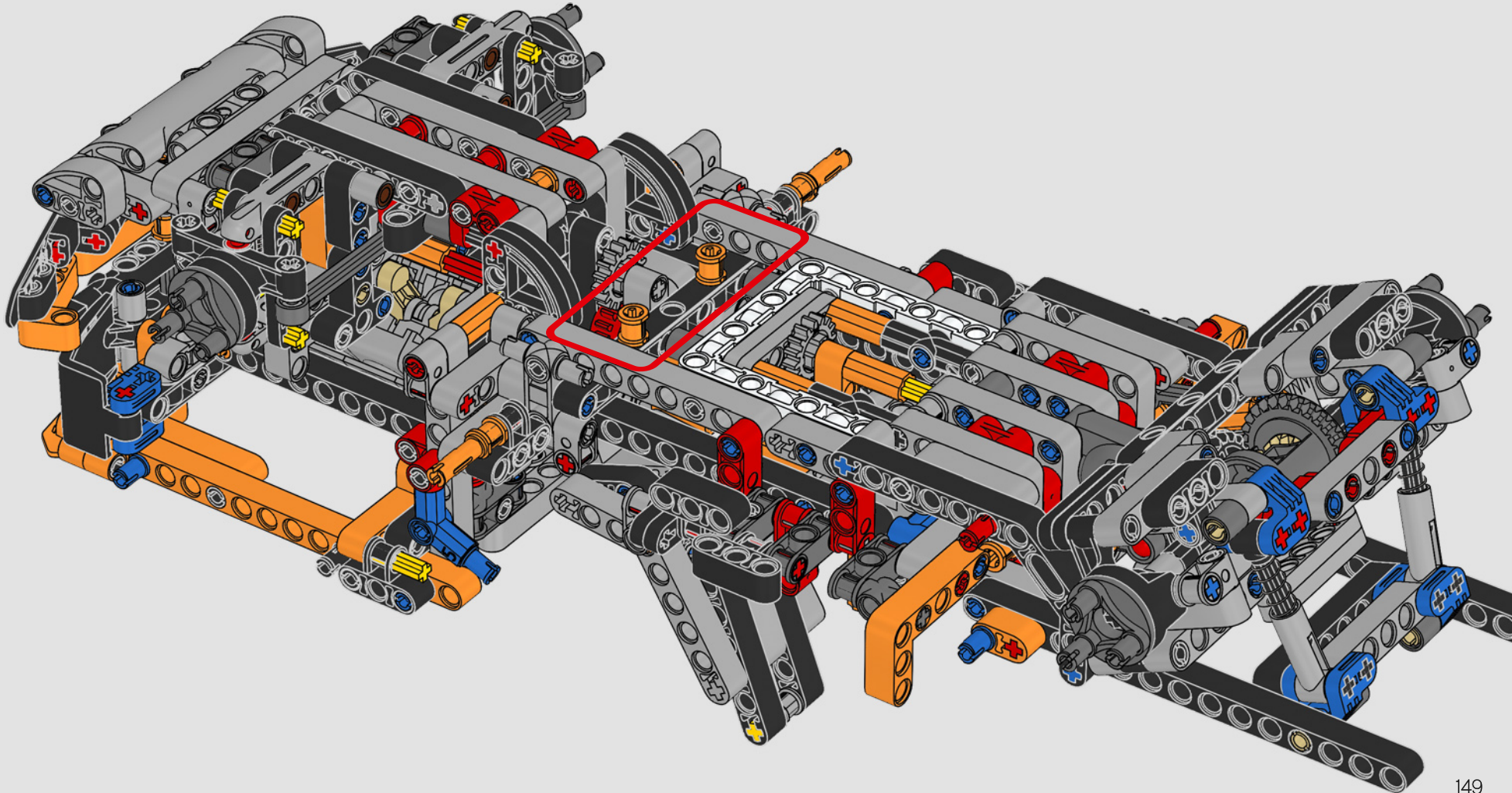

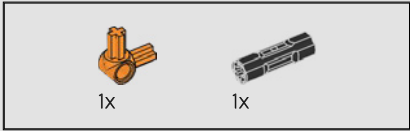
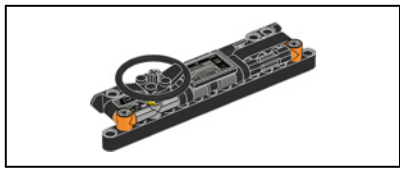

246

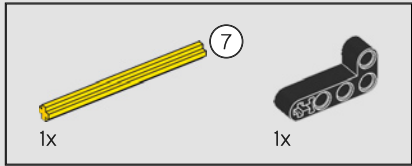
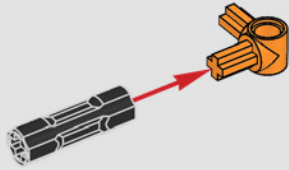

247

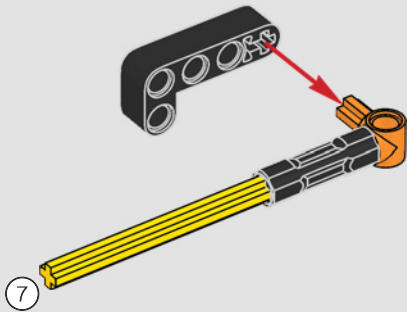

248

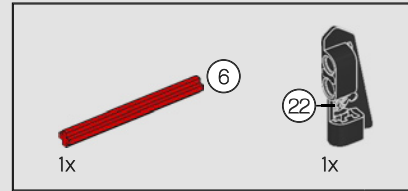
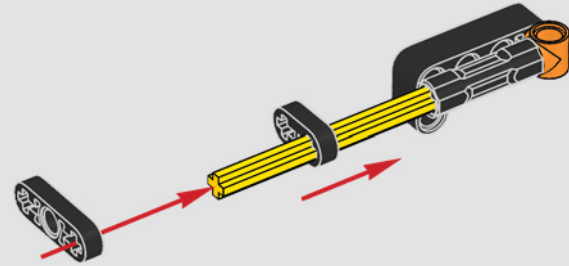

249

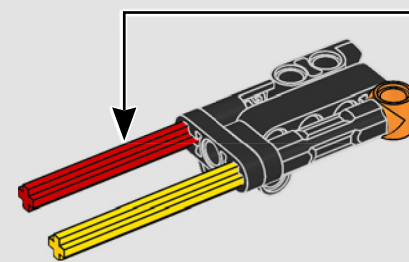
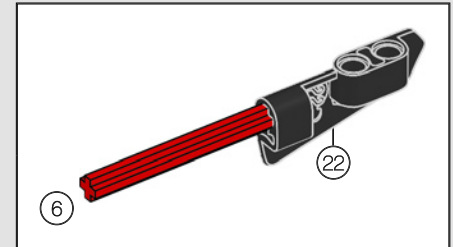

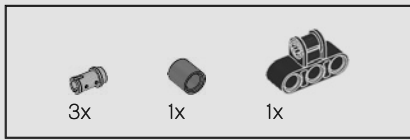

250

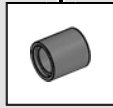
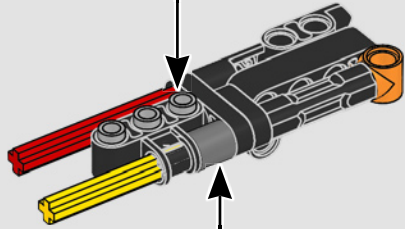
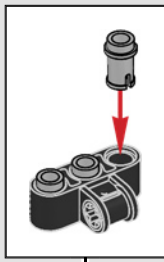

251

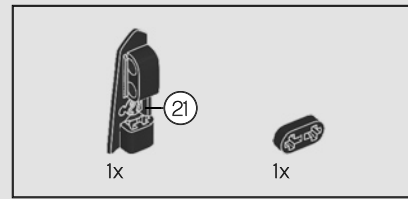
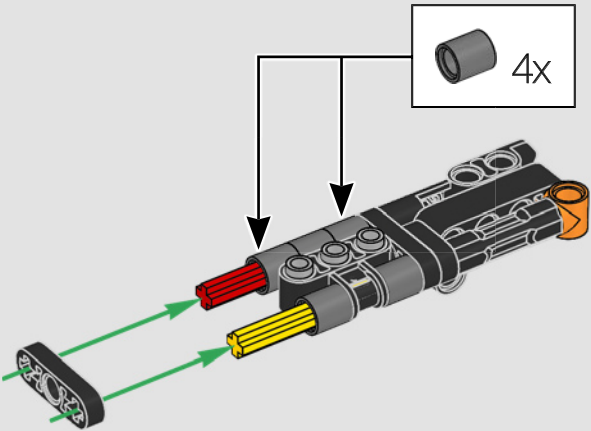

252

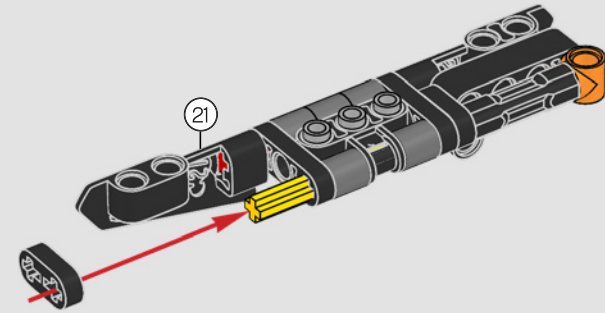

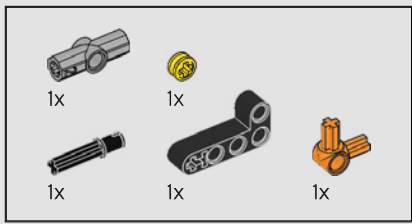

253

1

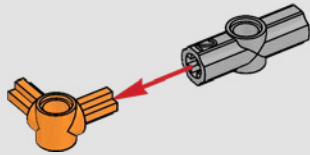

2

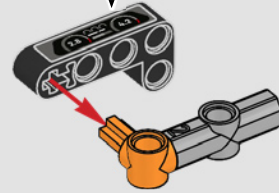
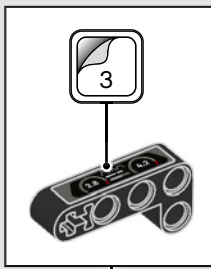

3

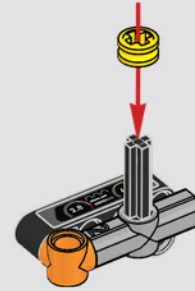

254

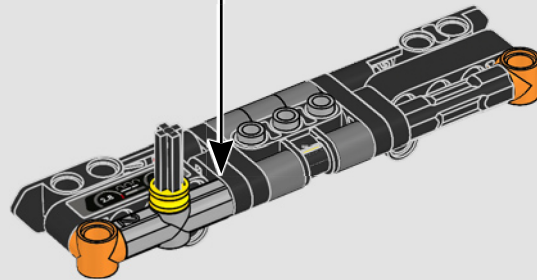



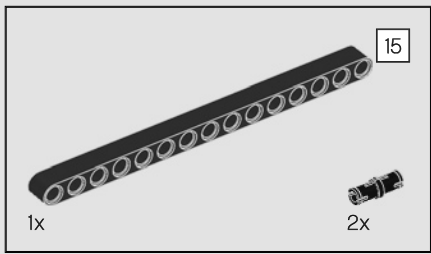

255

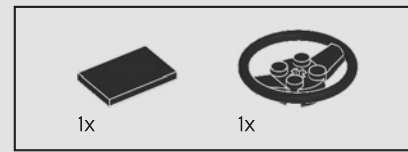
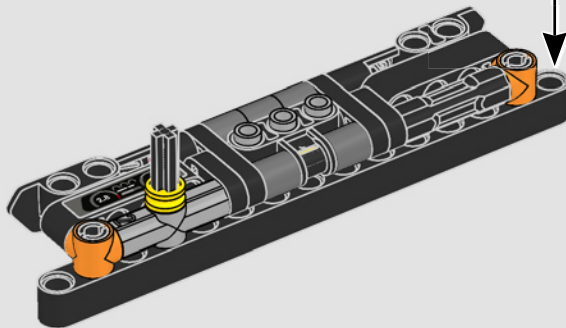
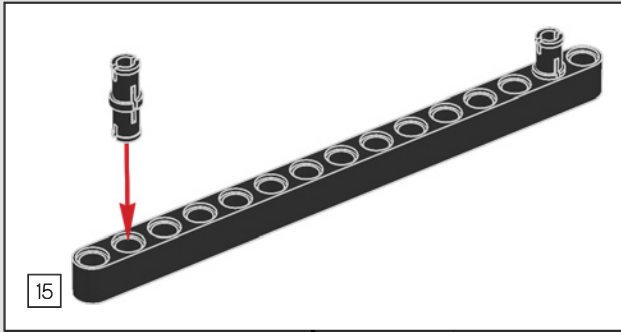

256

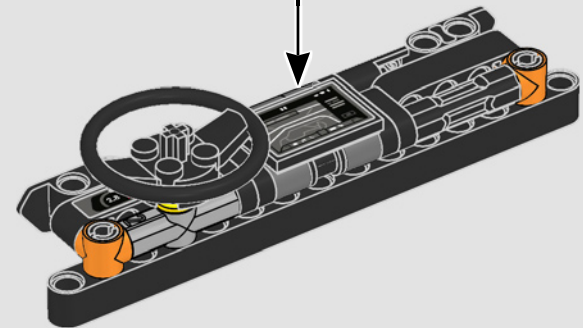
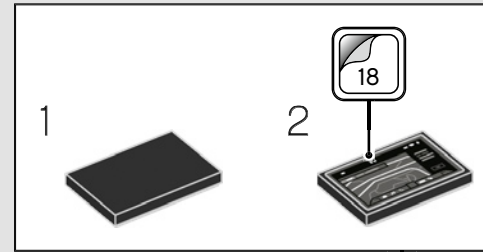

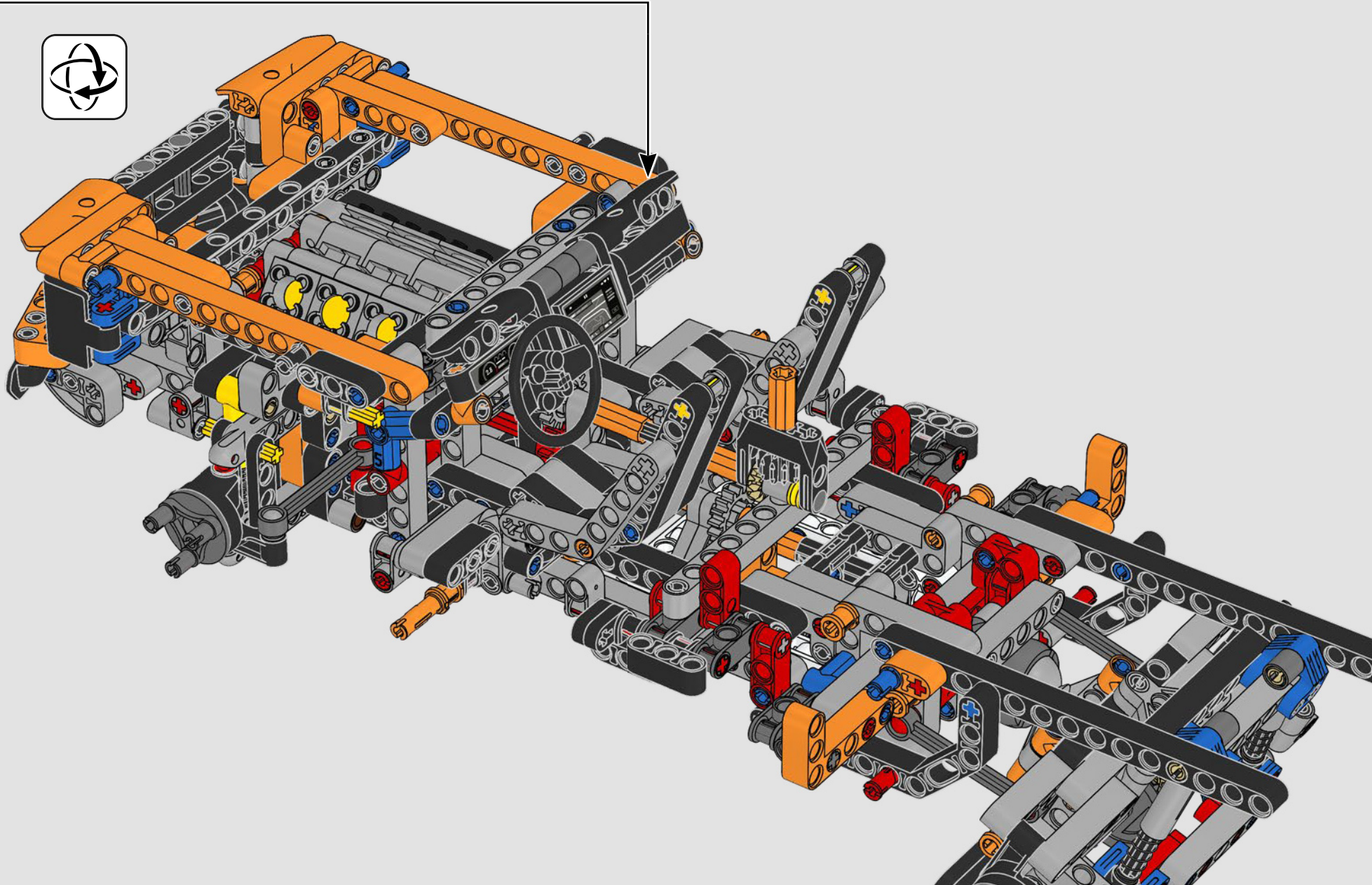

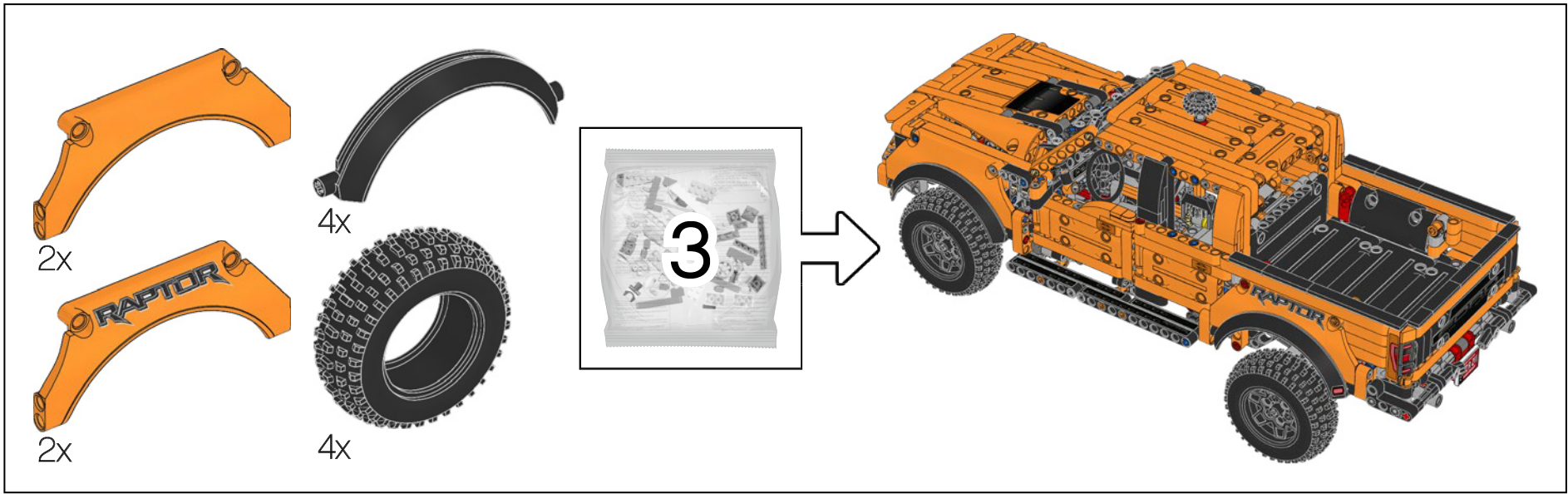



2x

258

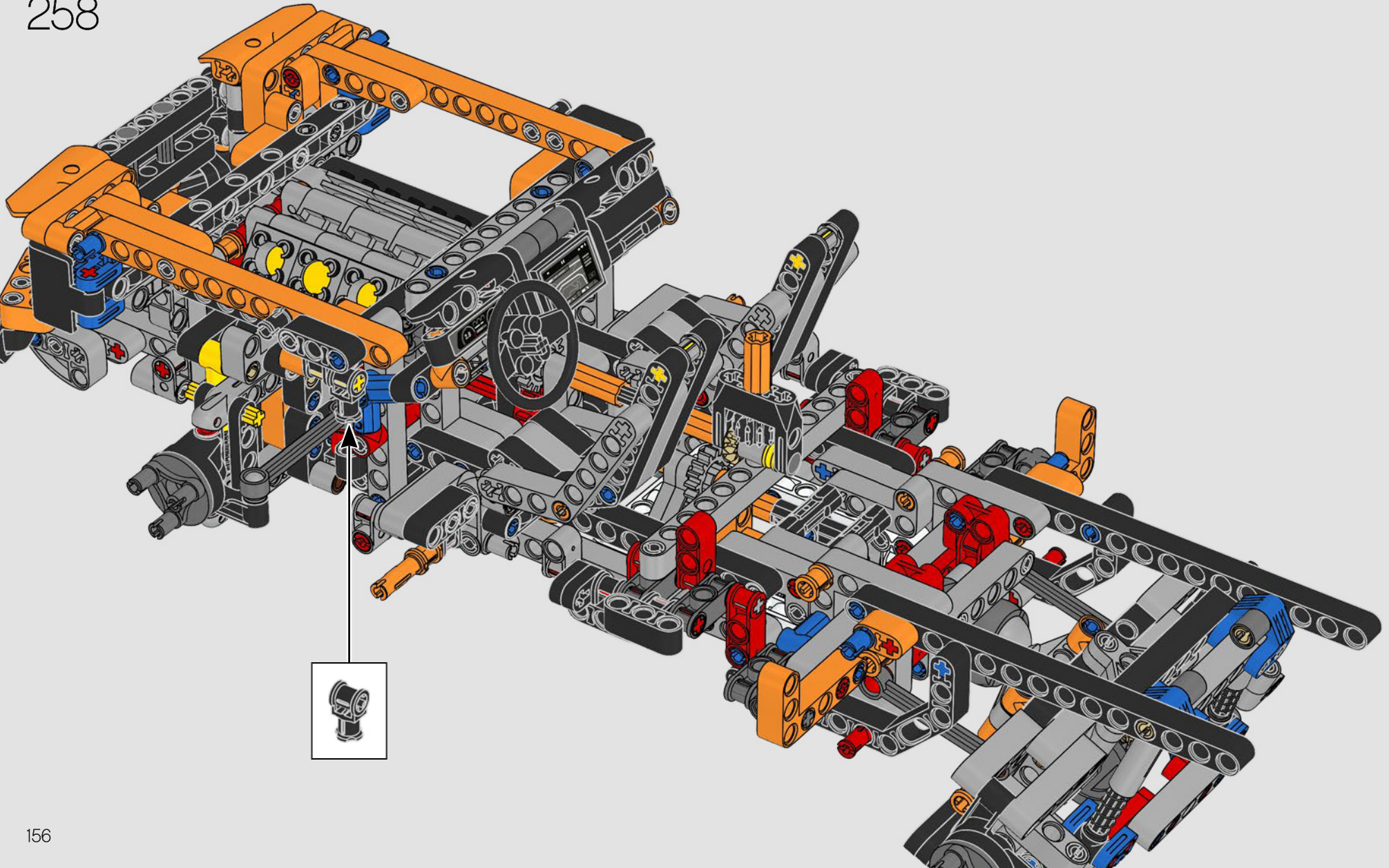

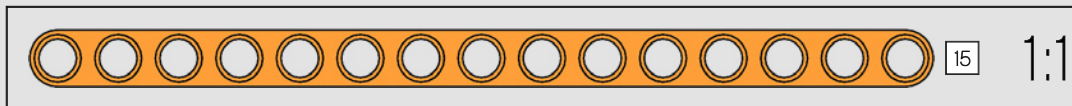
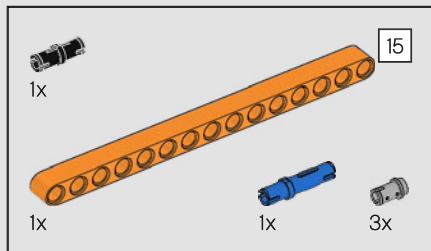

259

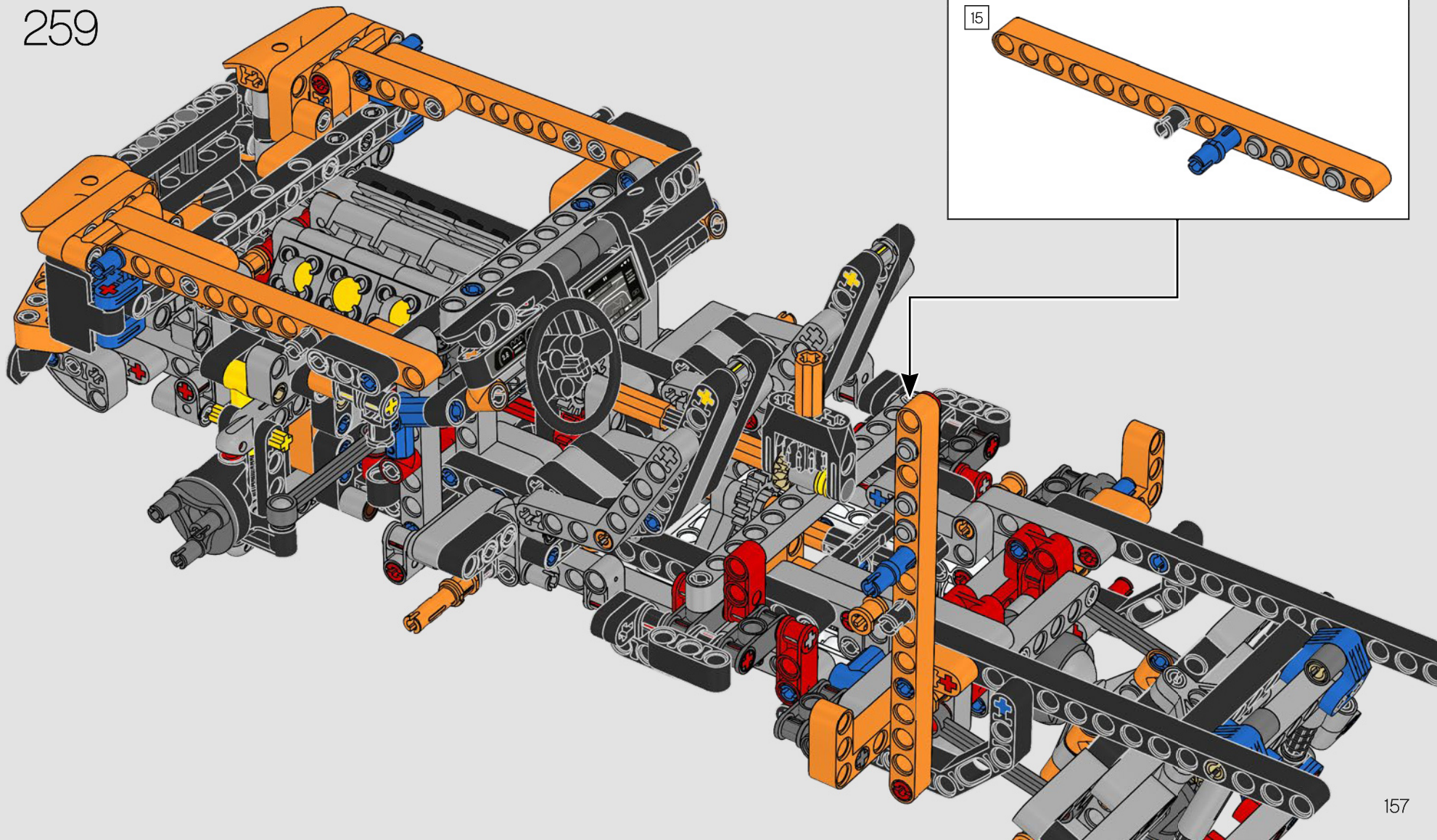
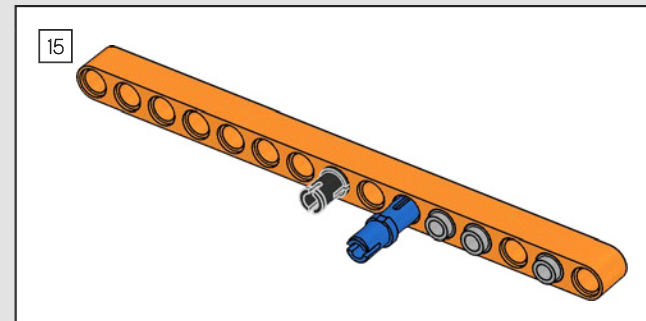

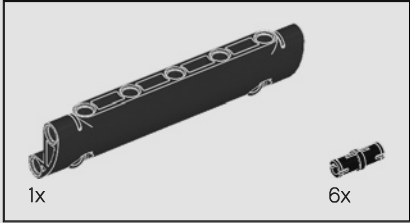
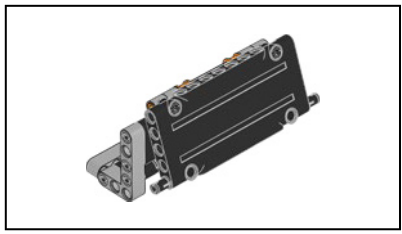

260

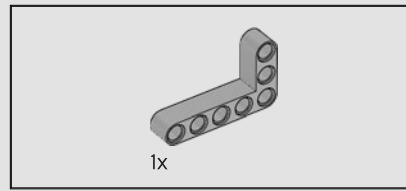
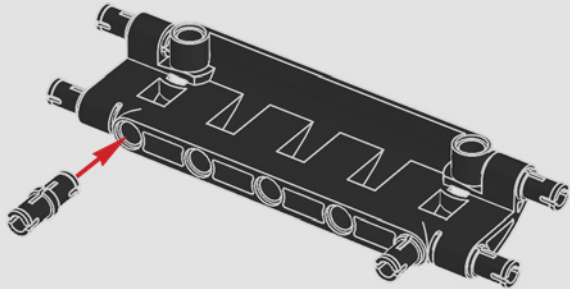

261

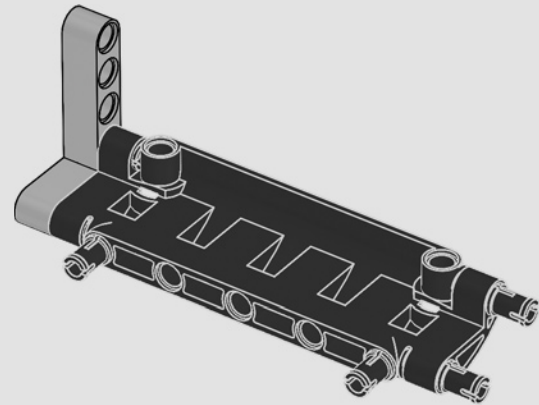

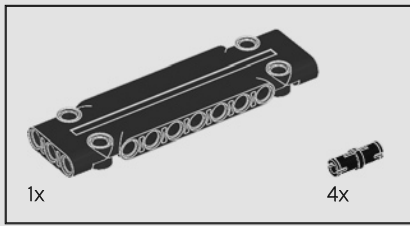

262

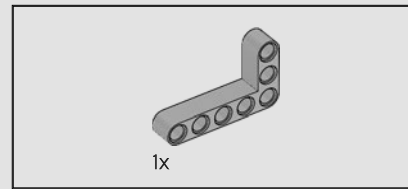
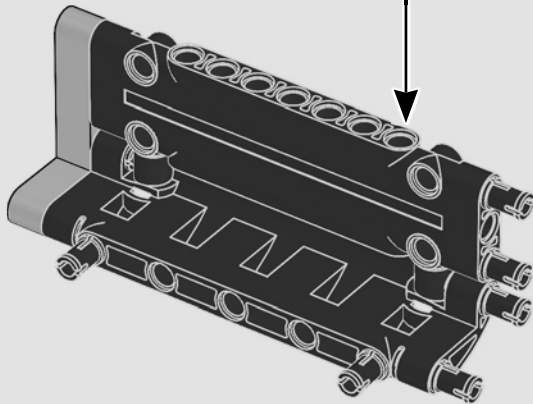
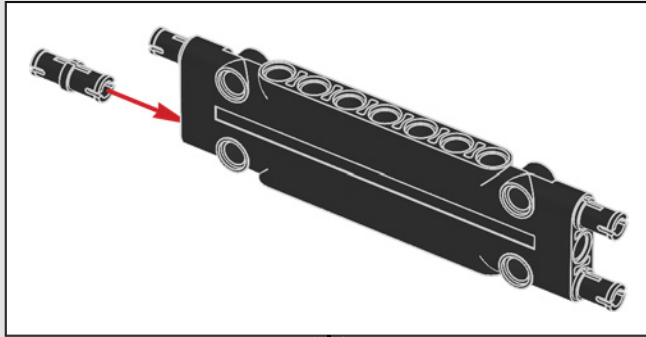

263

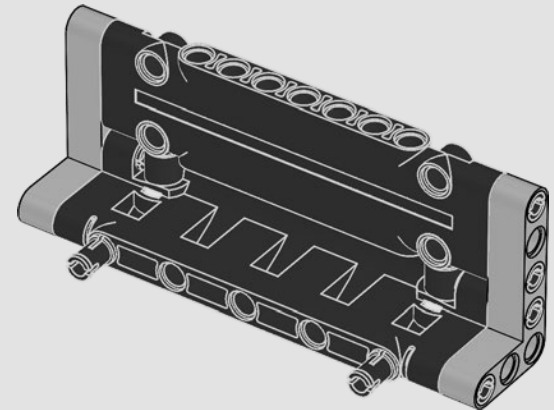

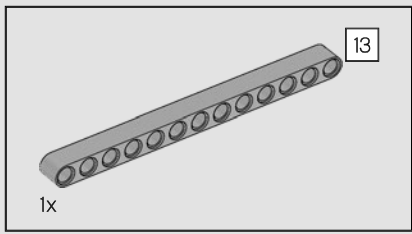

264

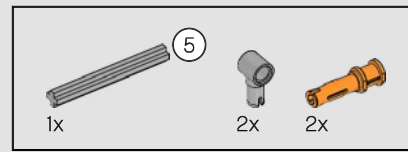
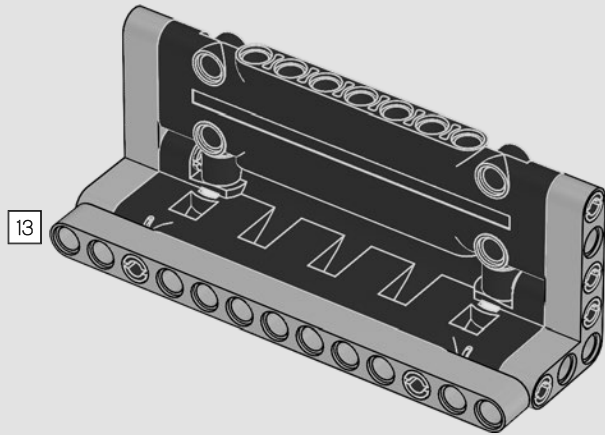

265

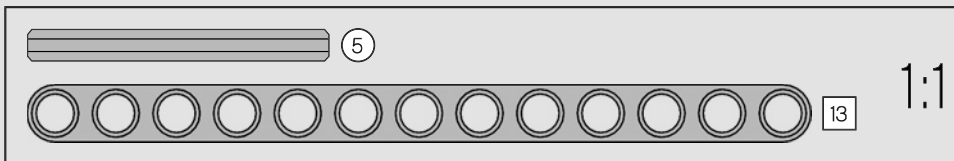
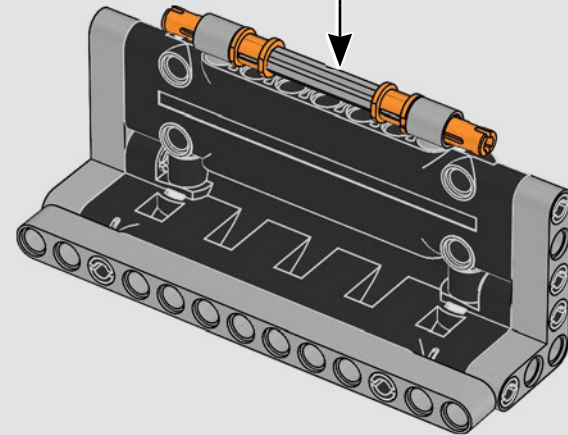
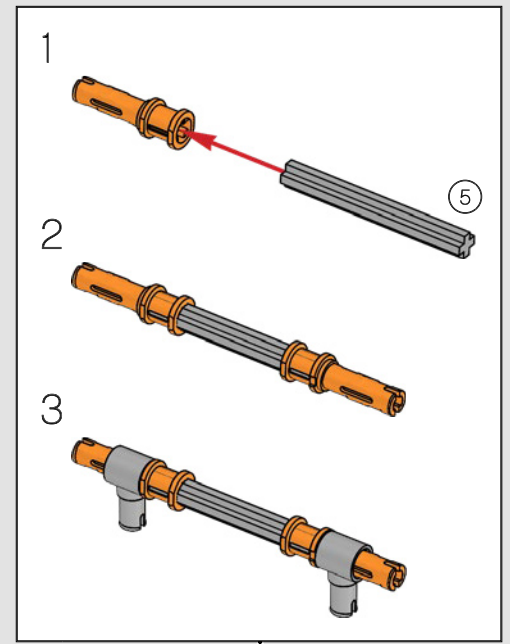





266

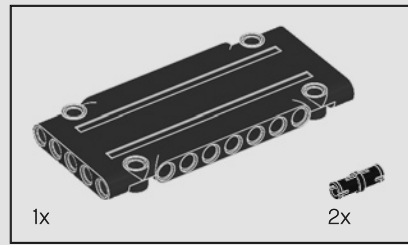
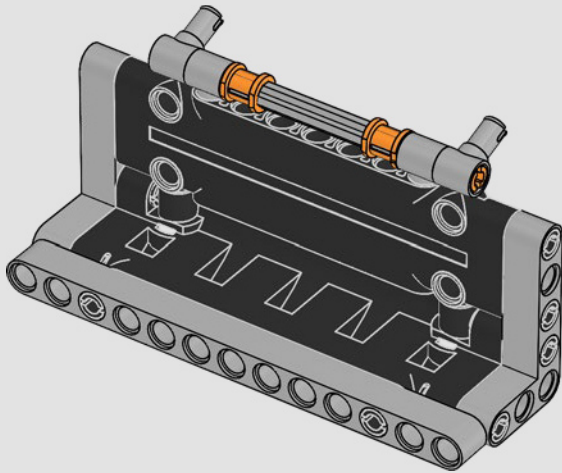

267

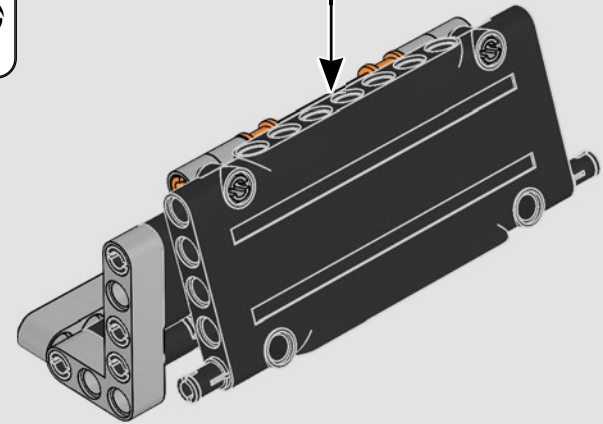
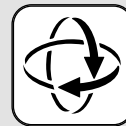
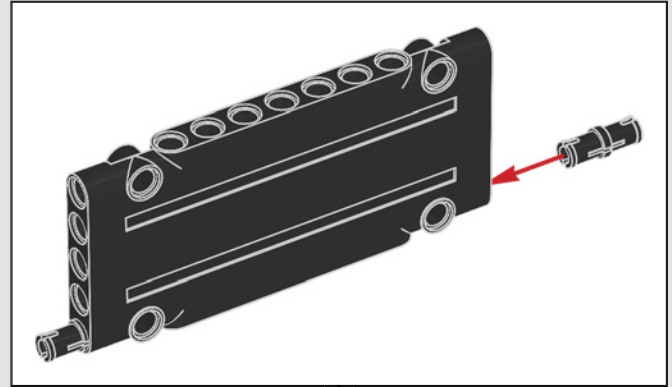

268

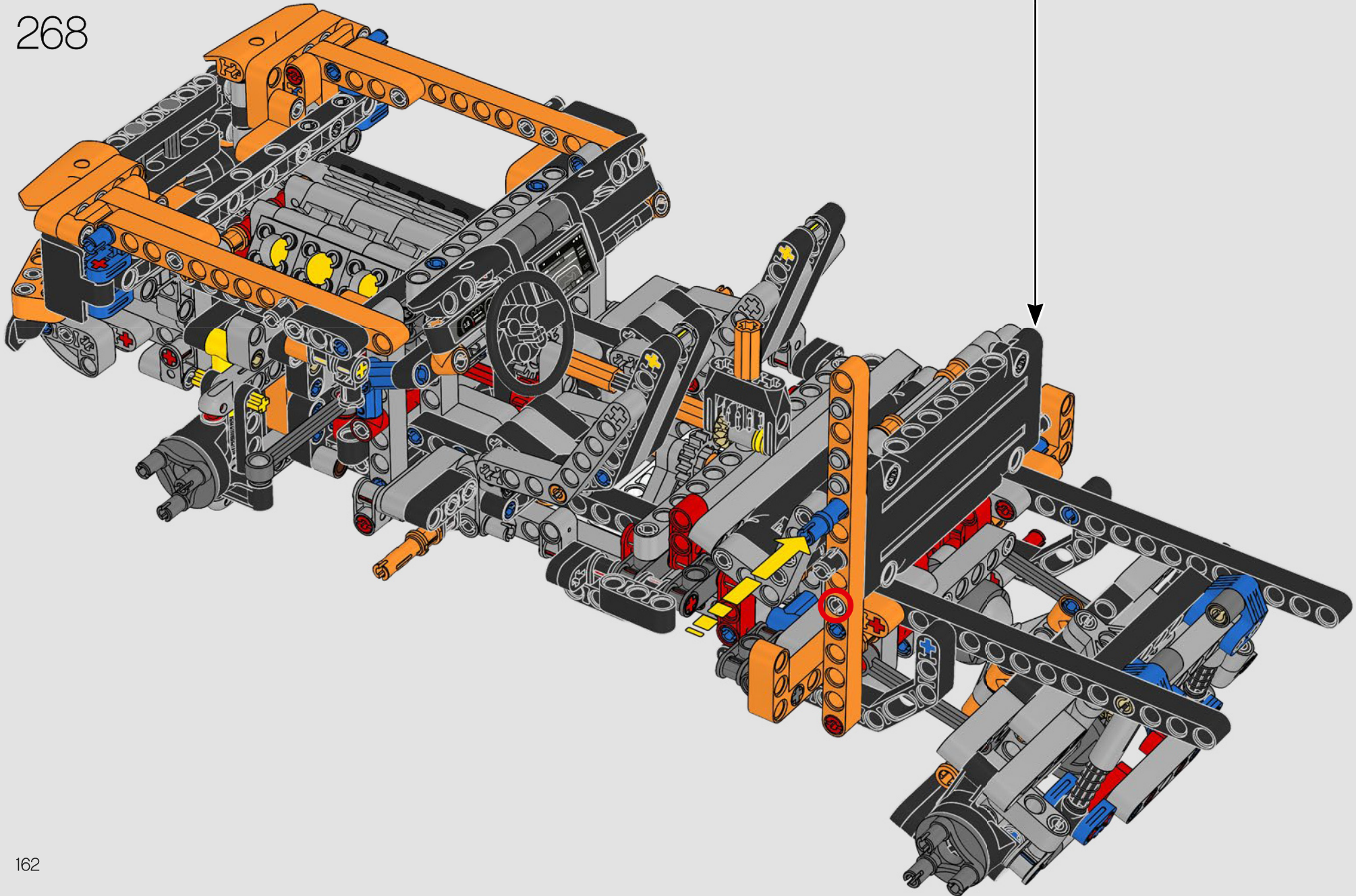

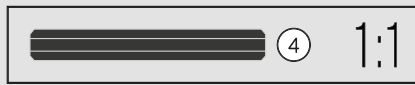
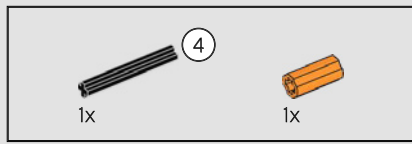

269

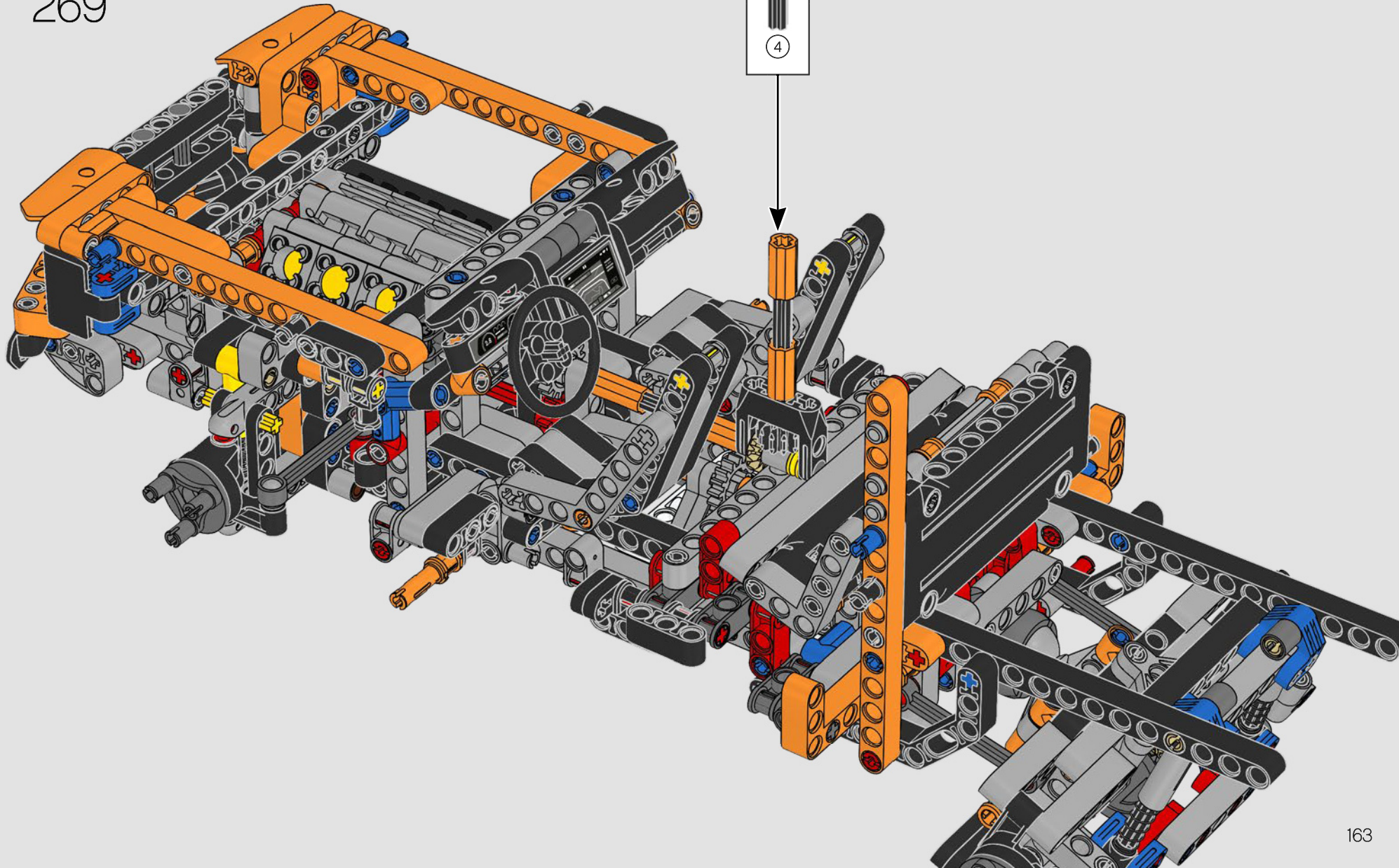
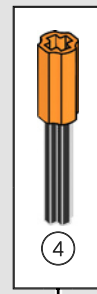

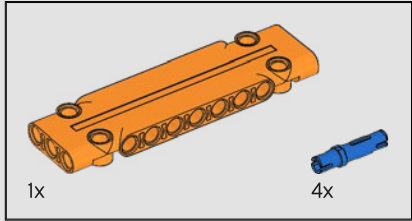
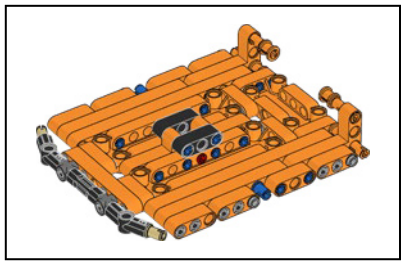

270

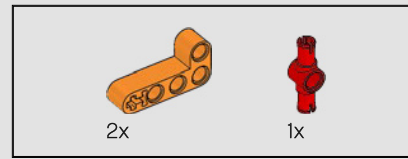
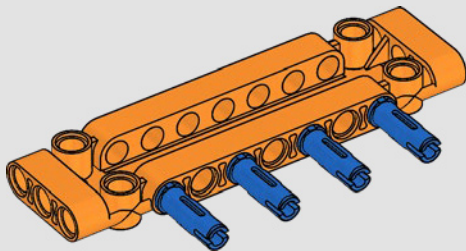

271

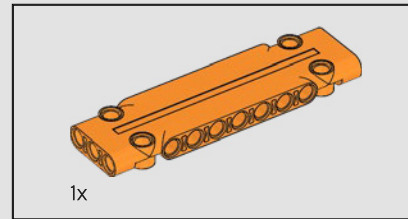
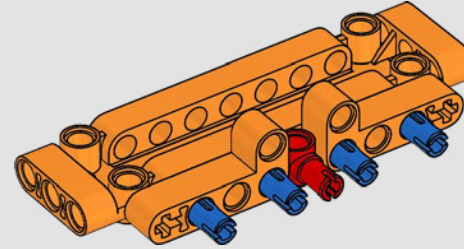

272

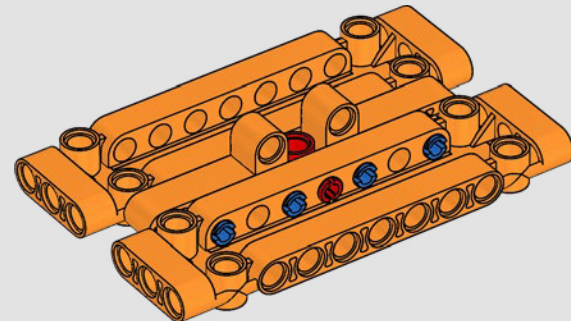

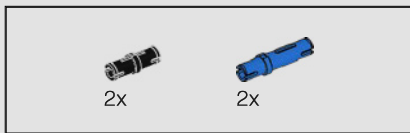

273

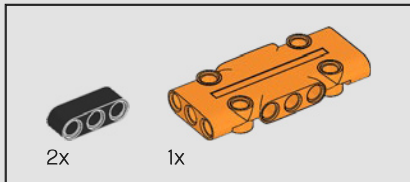
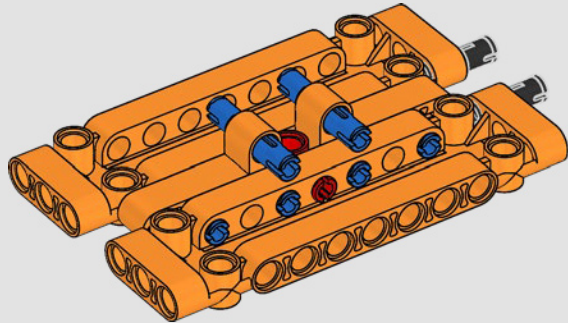

274

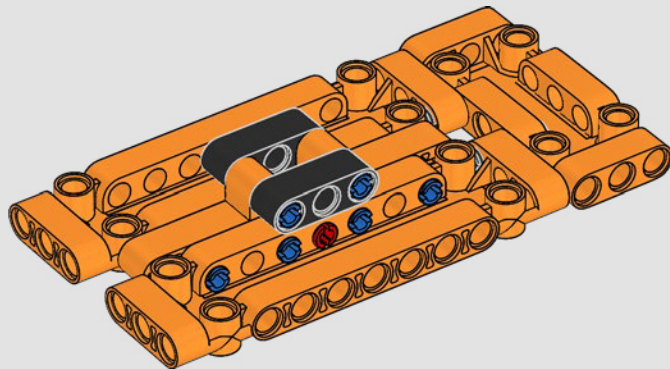

275

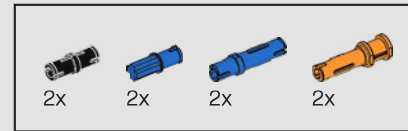
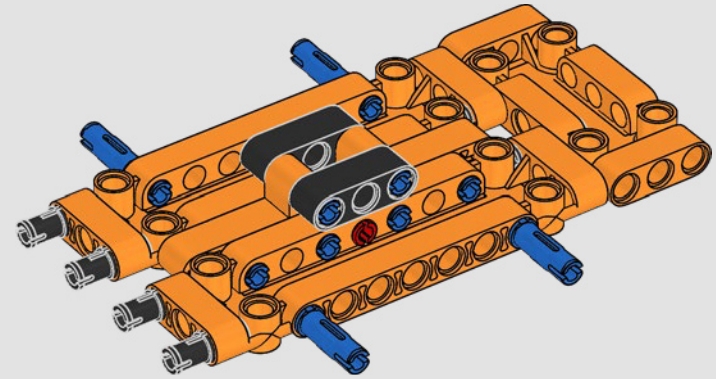

276

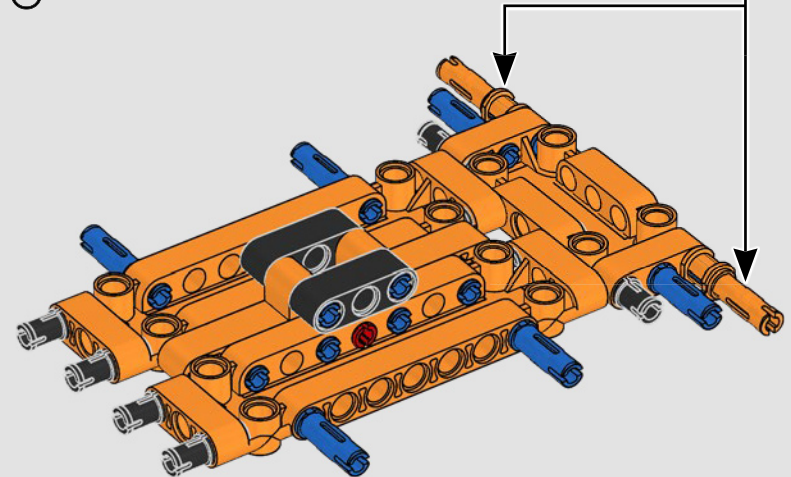
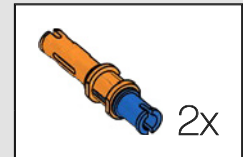

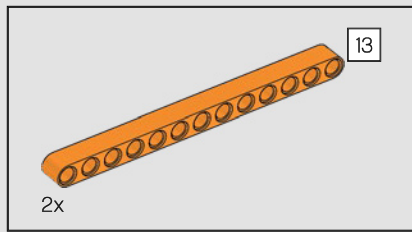

277

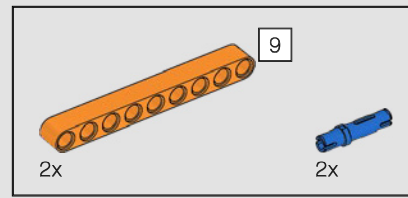
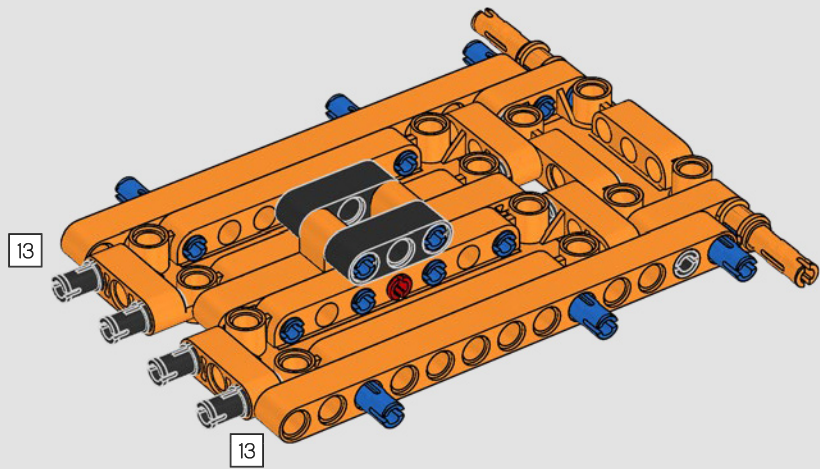

278

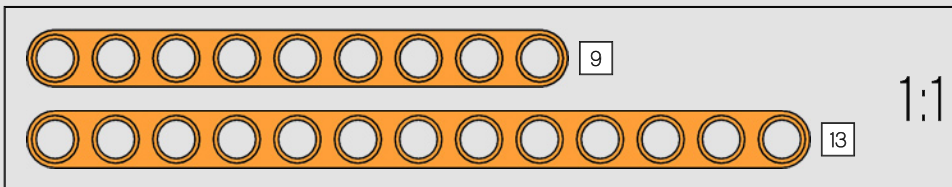
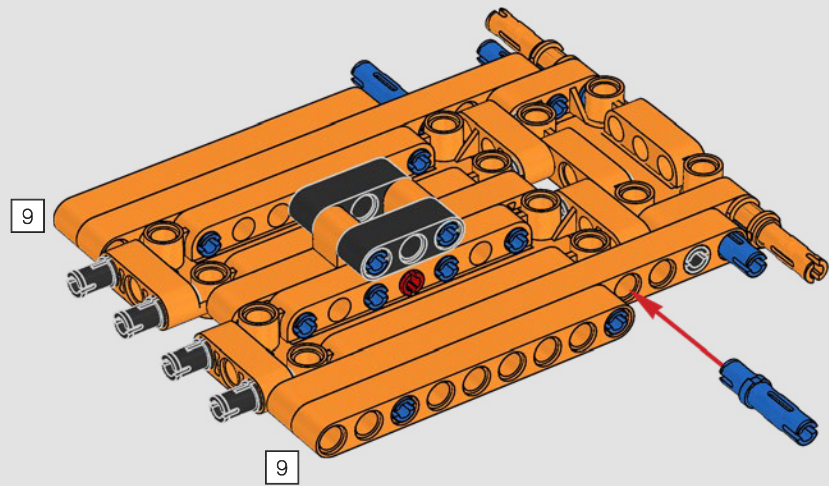

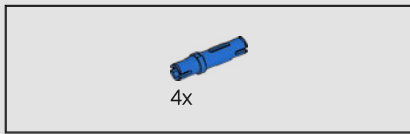

279

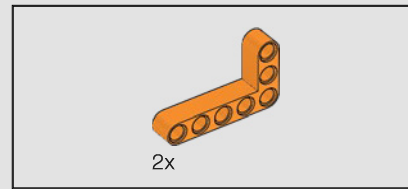
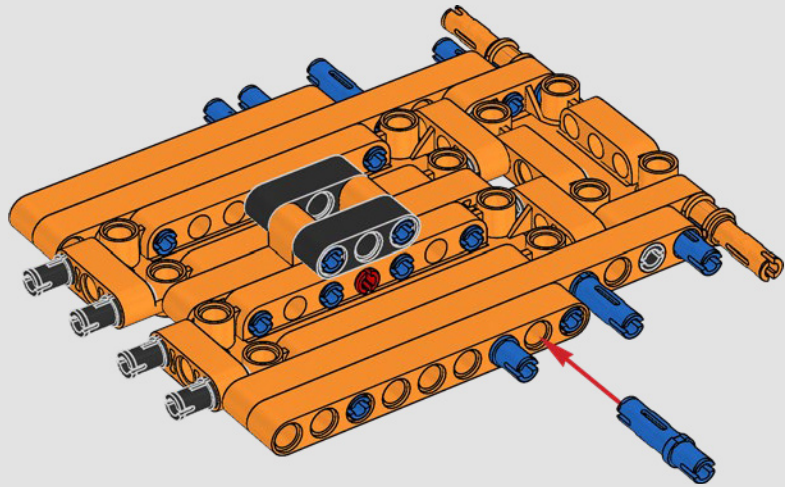

280

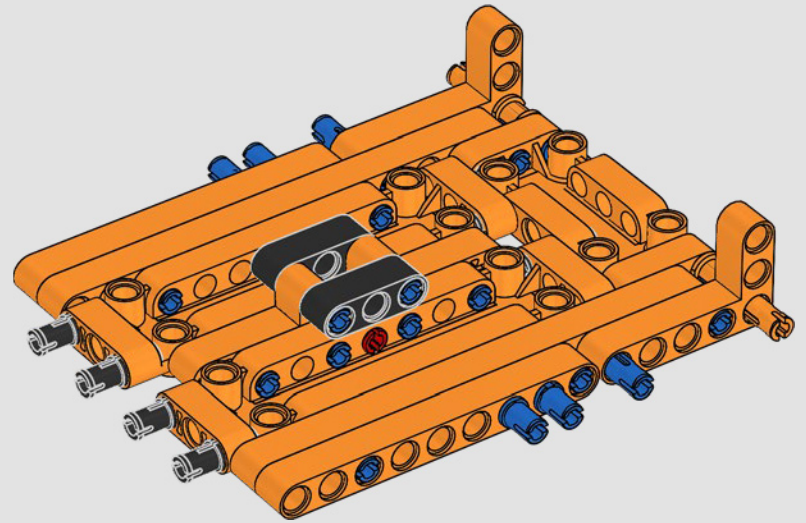



12x

281

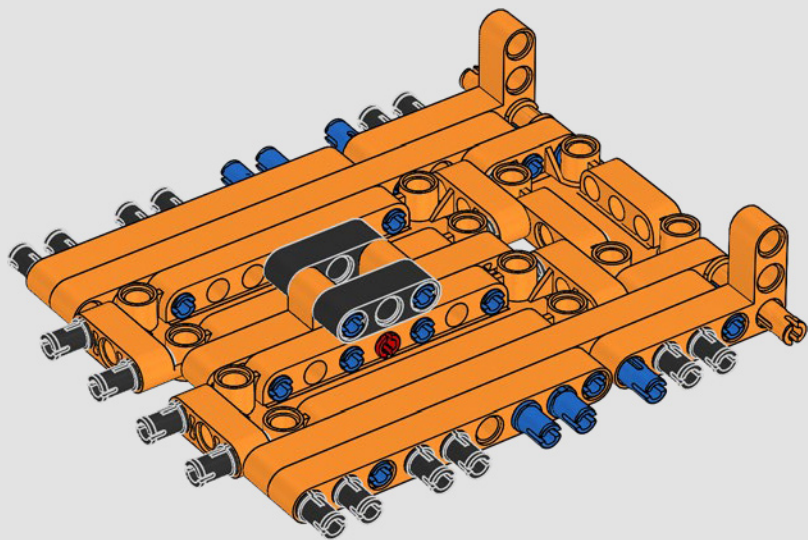

8x

282

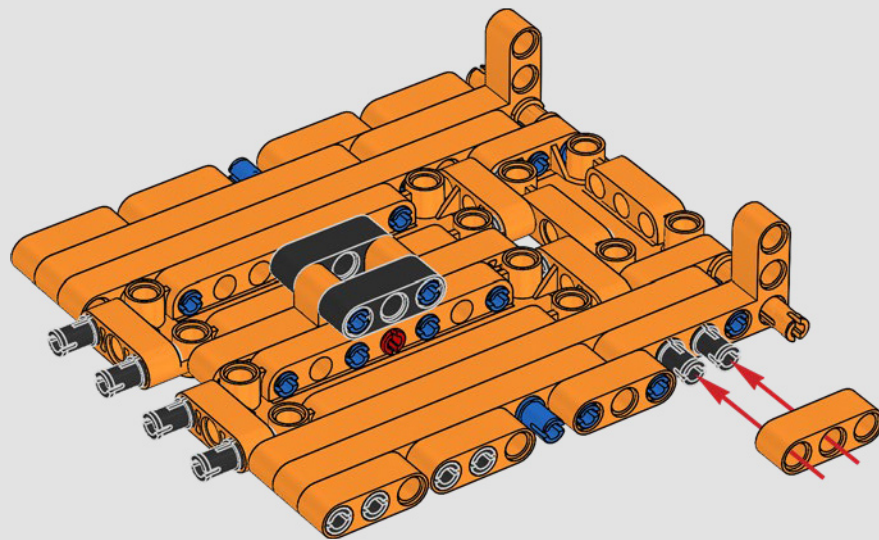



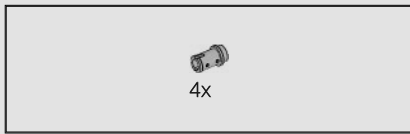

283

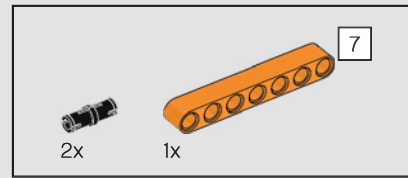
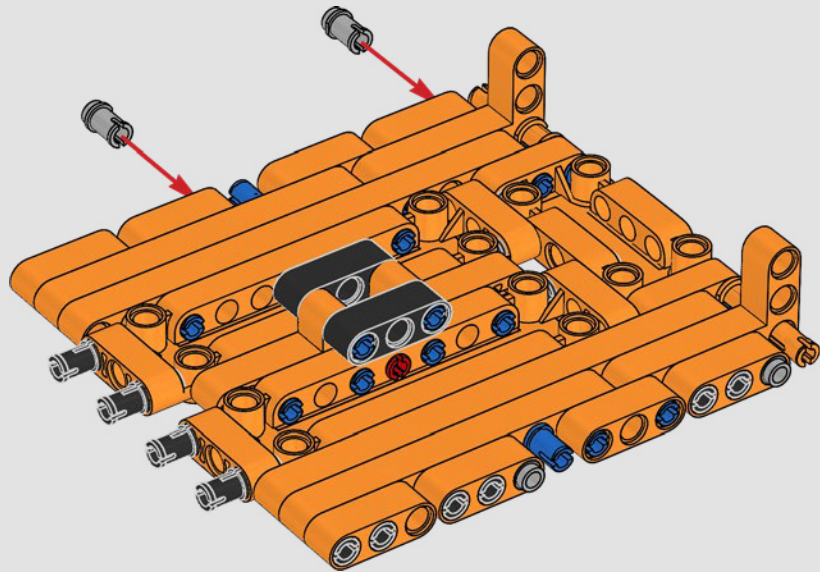

284

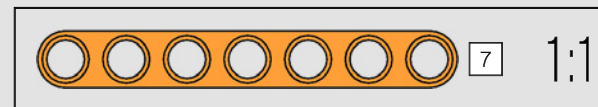
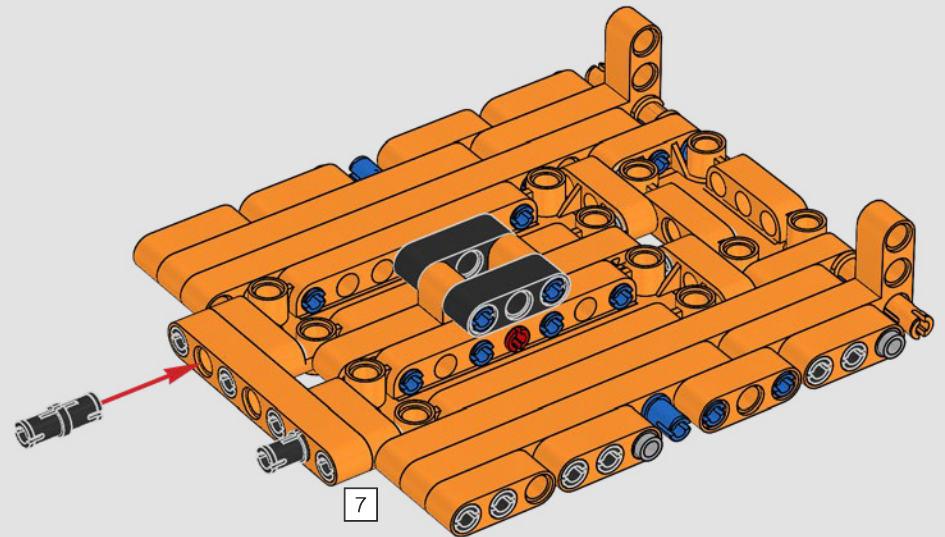

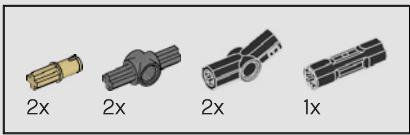

285

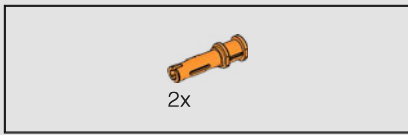
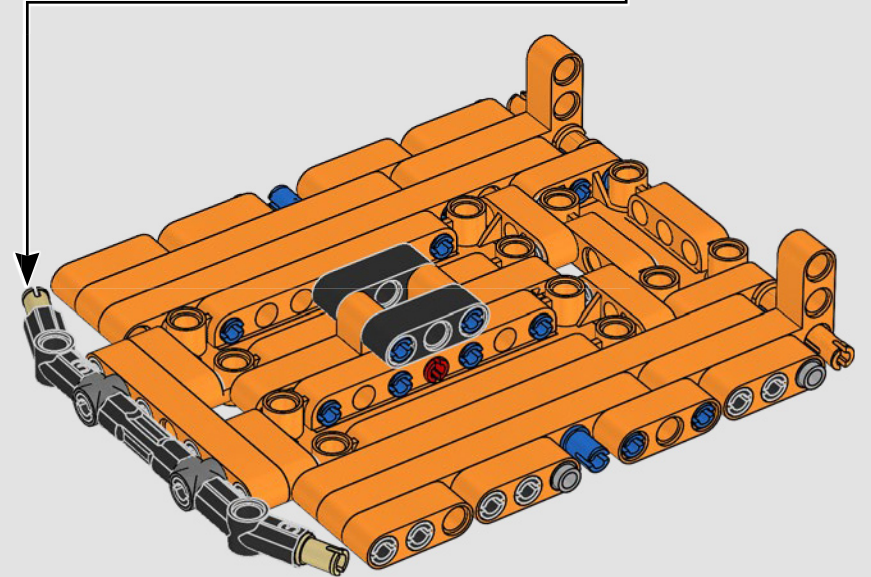
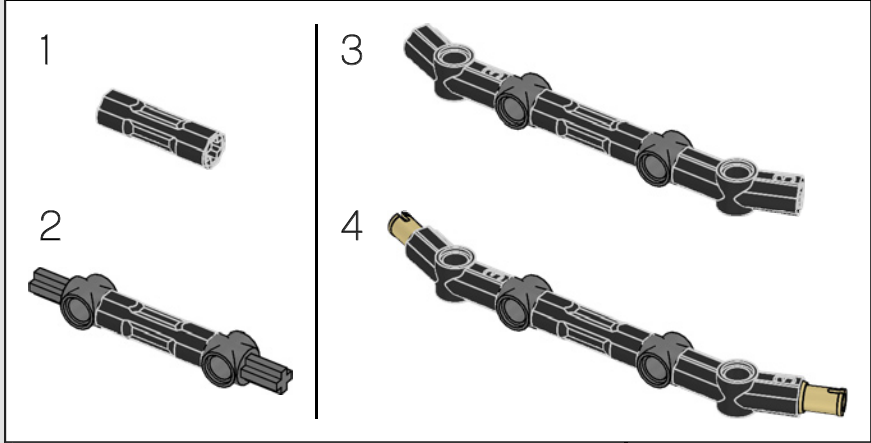

286

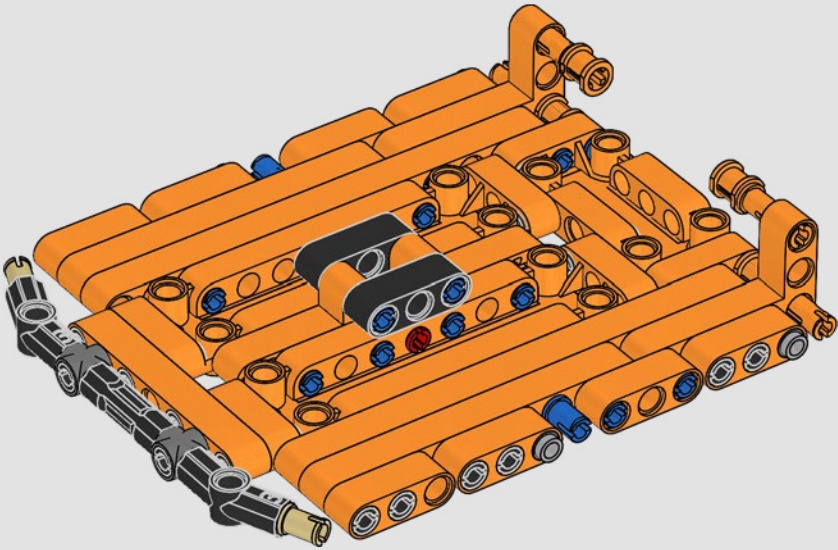

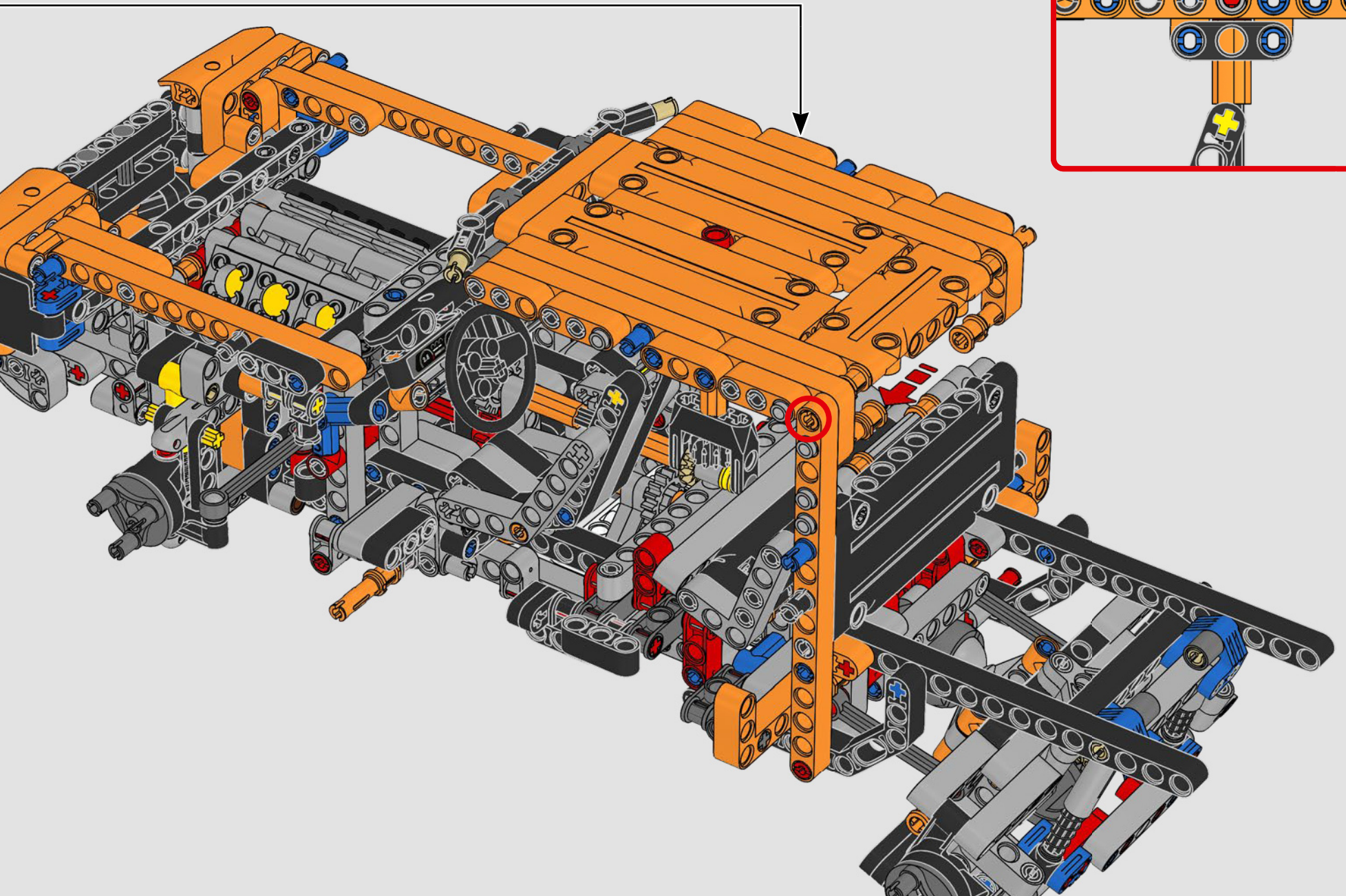

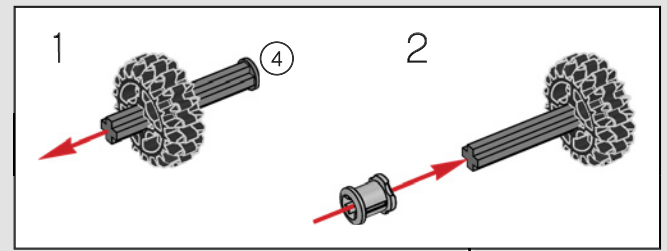
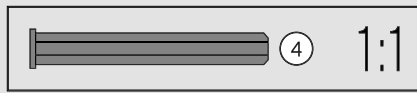
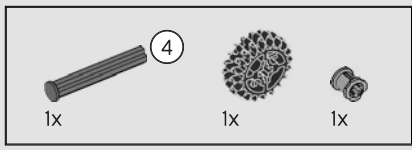

288

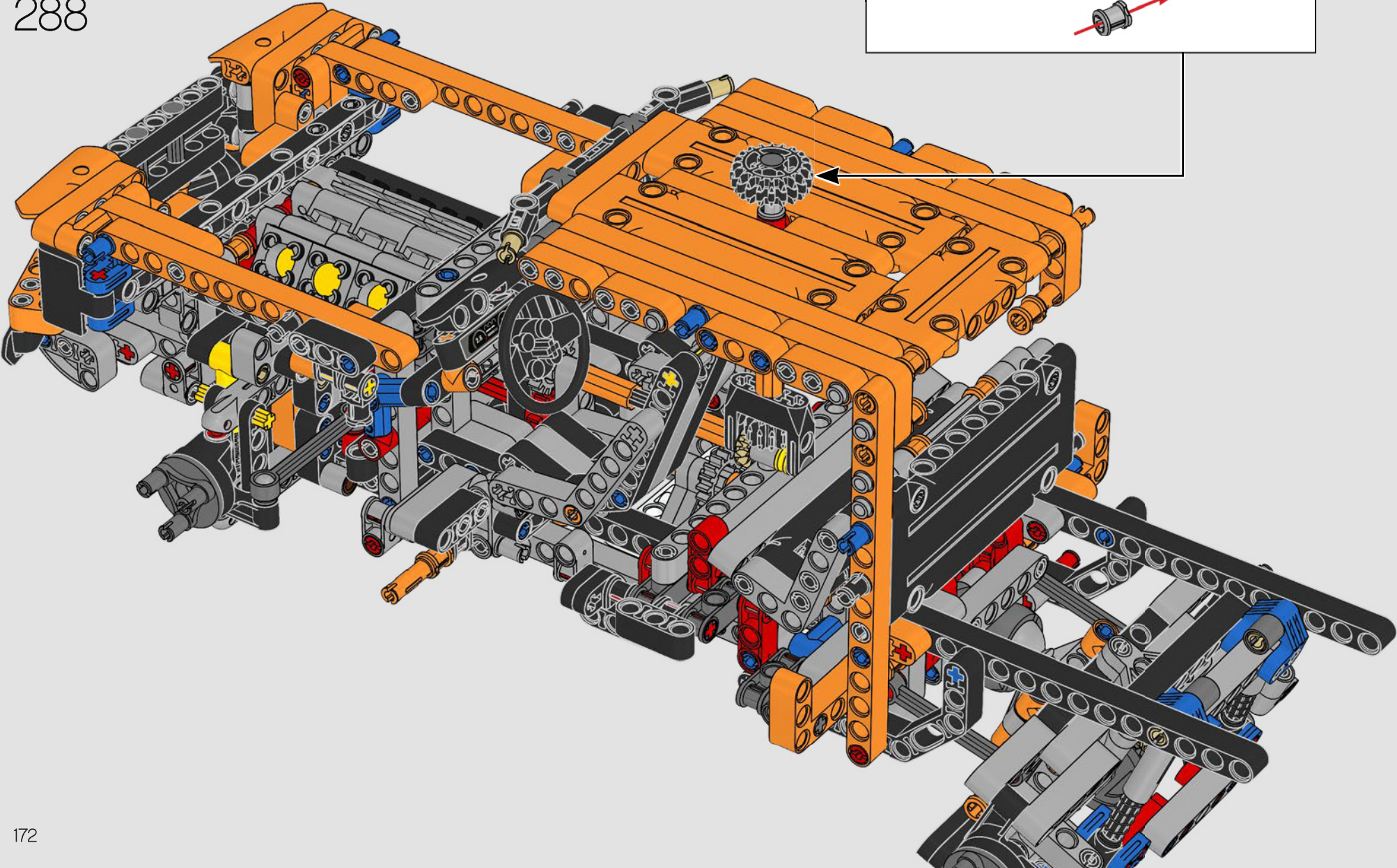

Le F-150 Raptor est également muni d'un régulateur de vitesse high-tech pour la conduite sur les surfaces à faible adhérence.

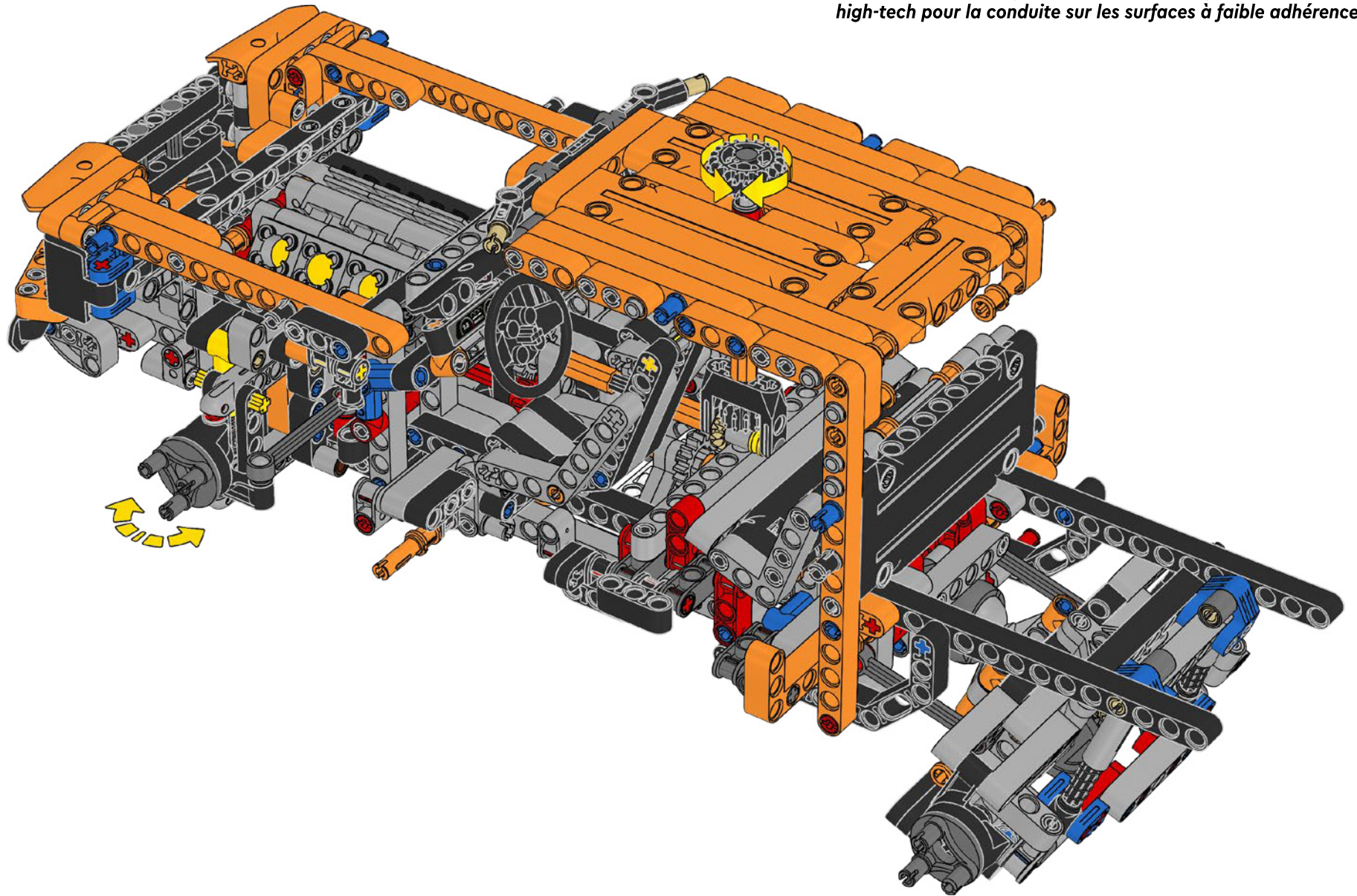

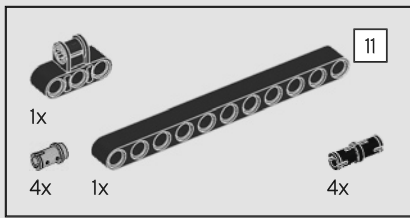

289

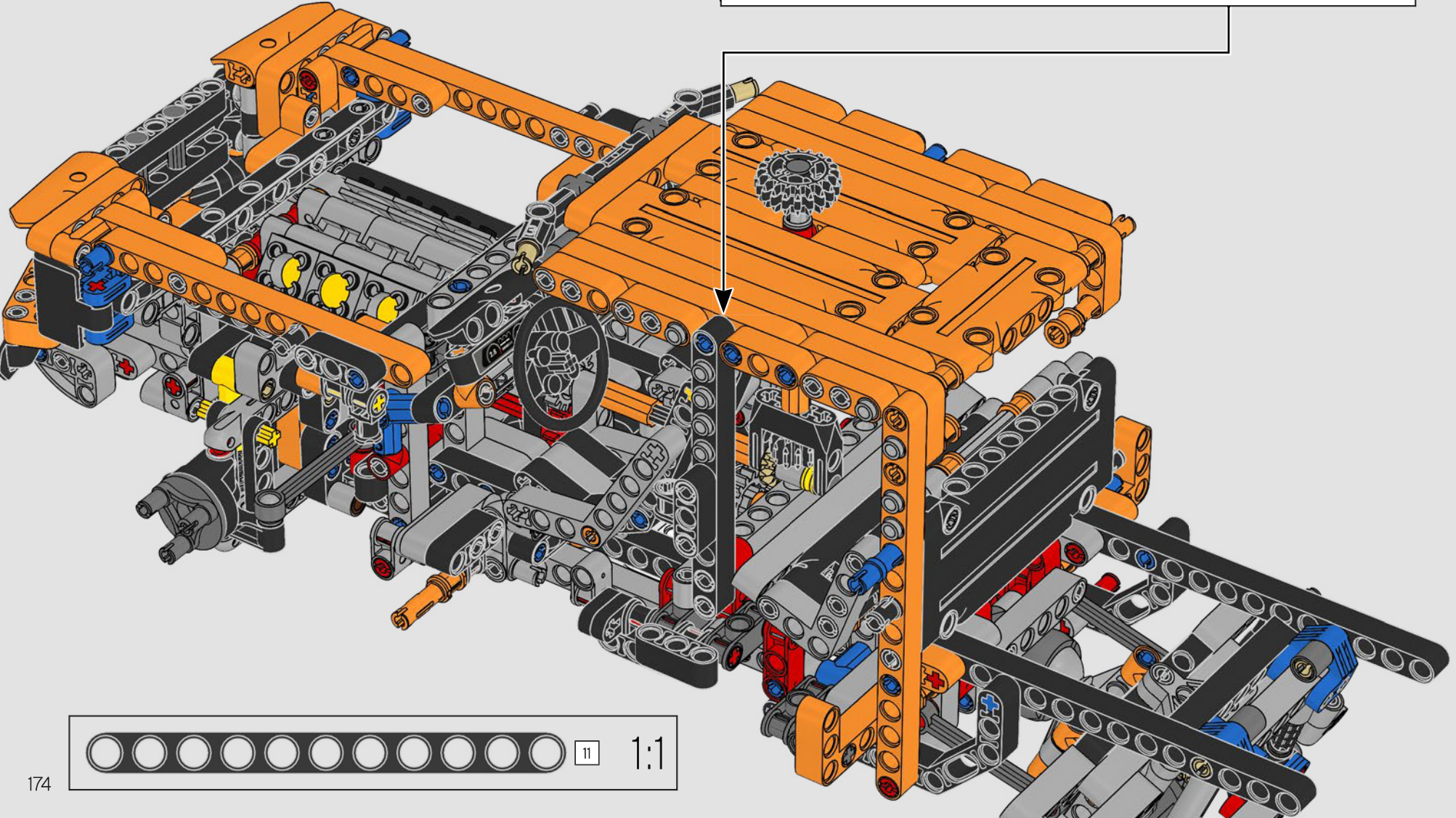
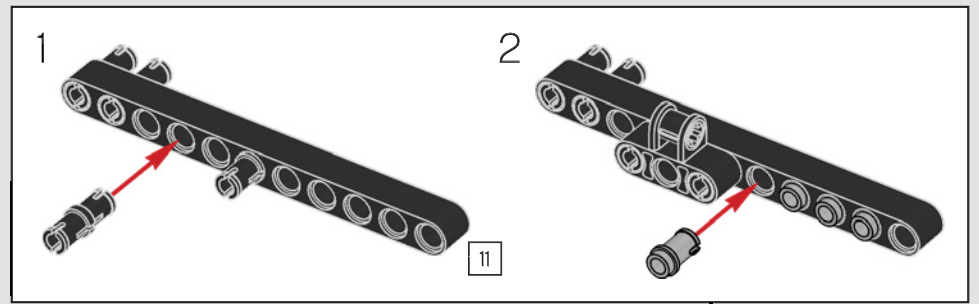

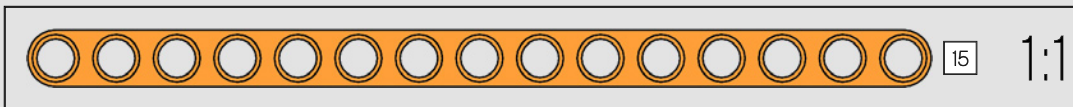
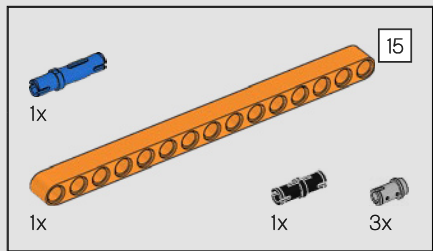

290

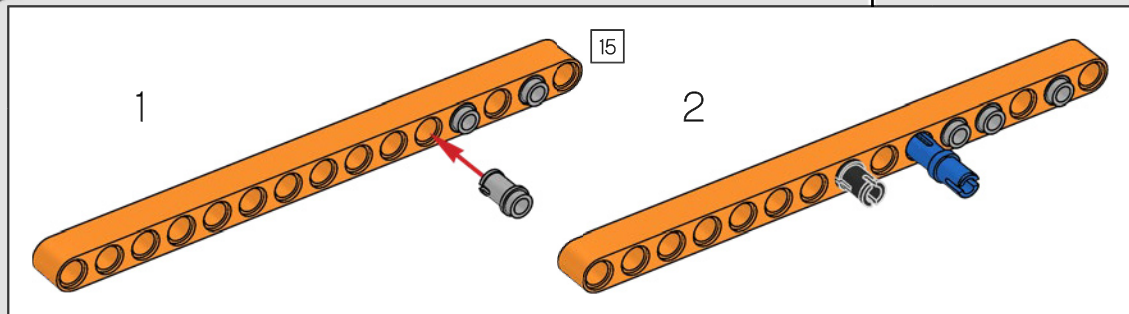
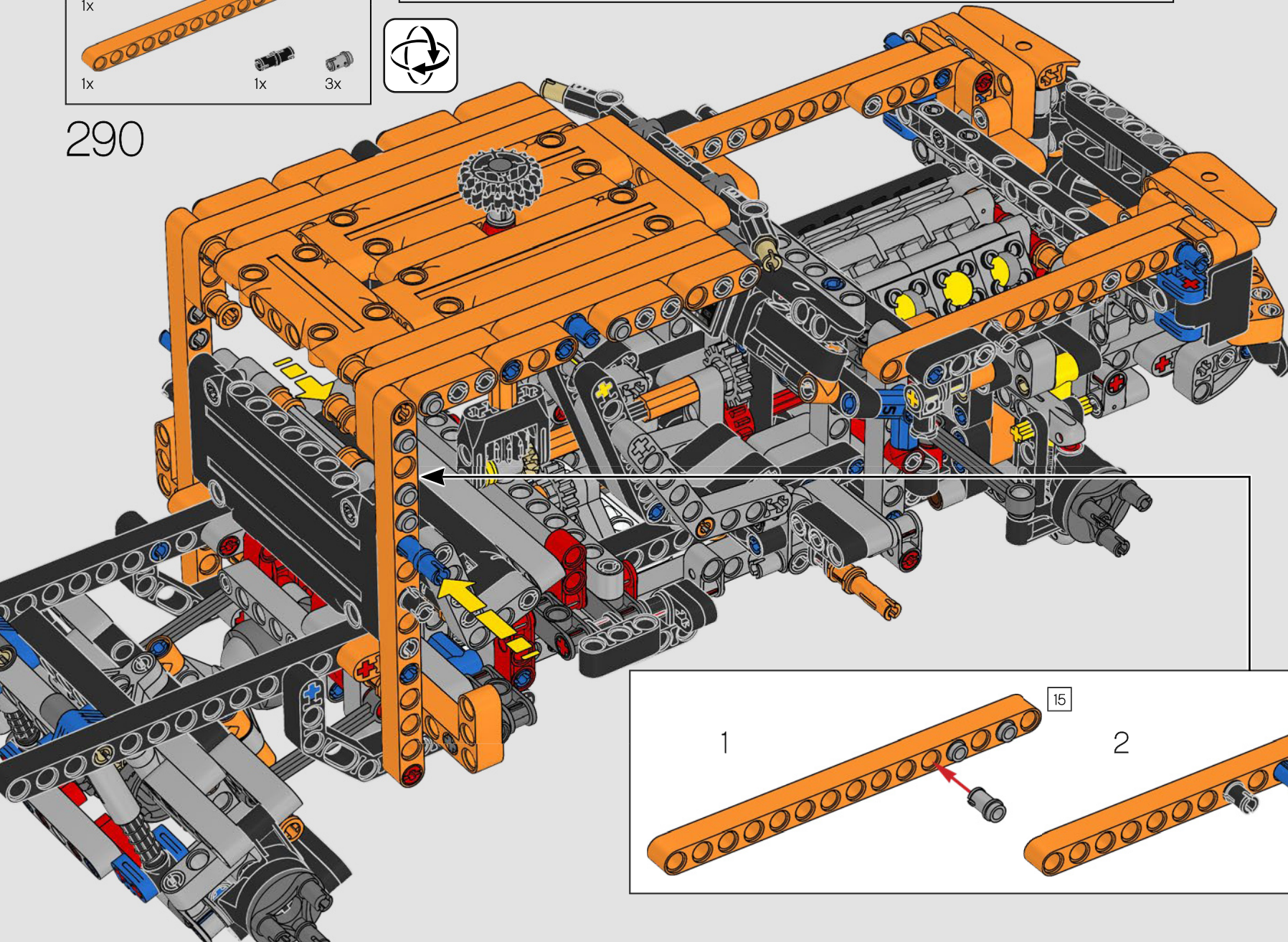

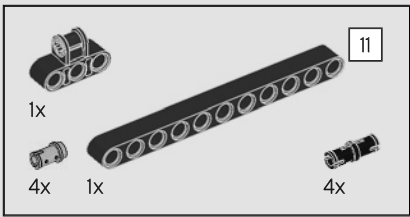

291

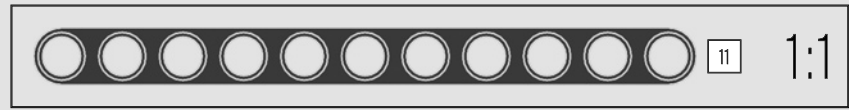
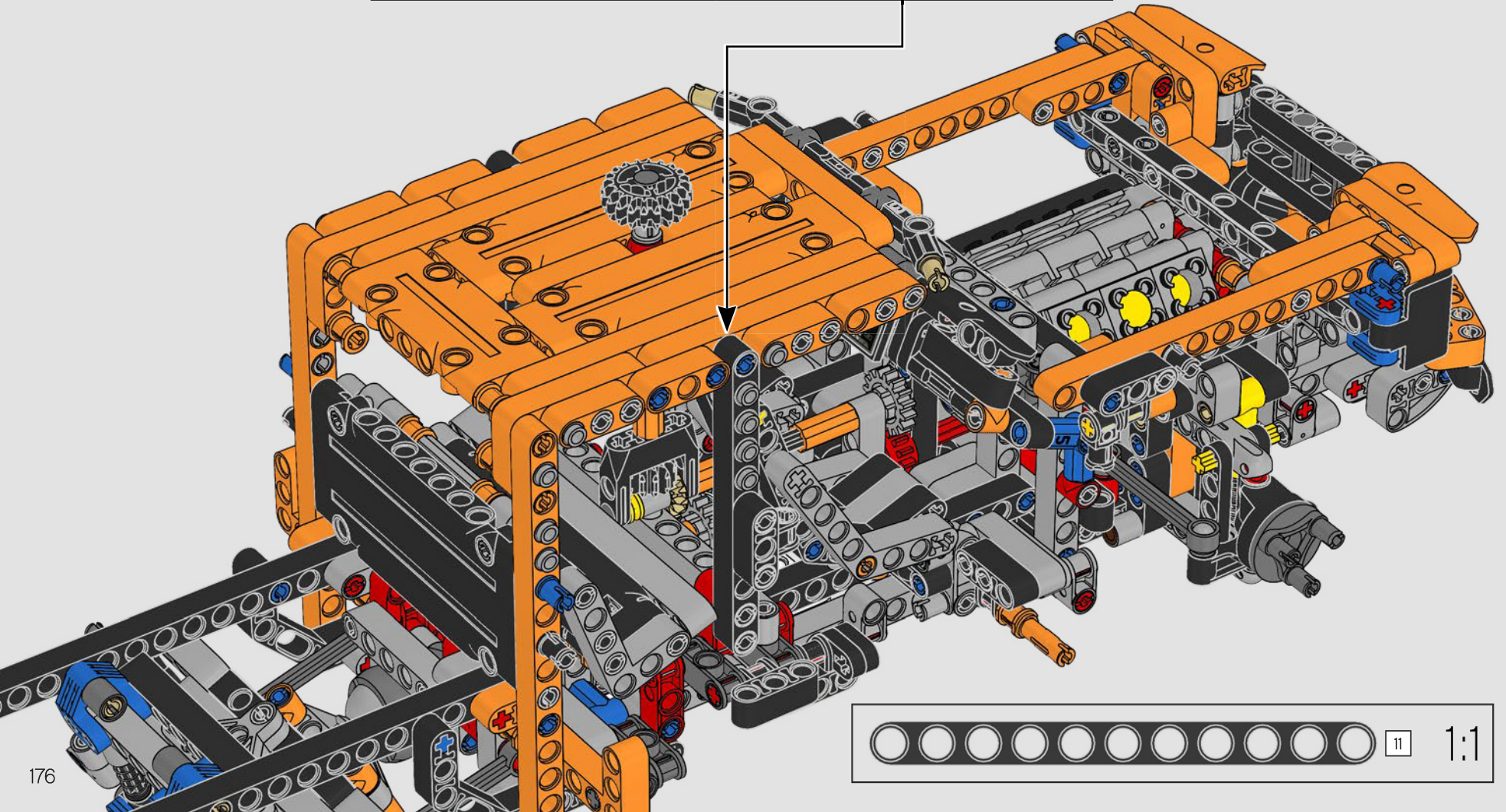
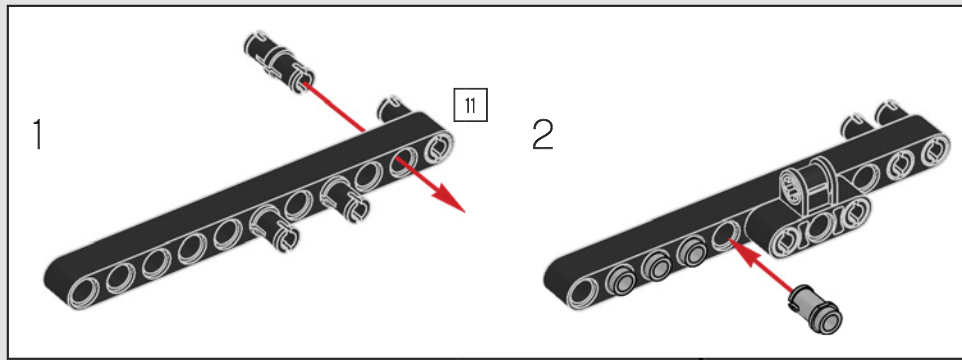



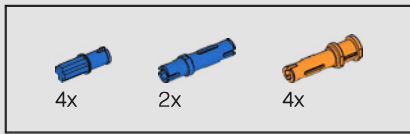

292

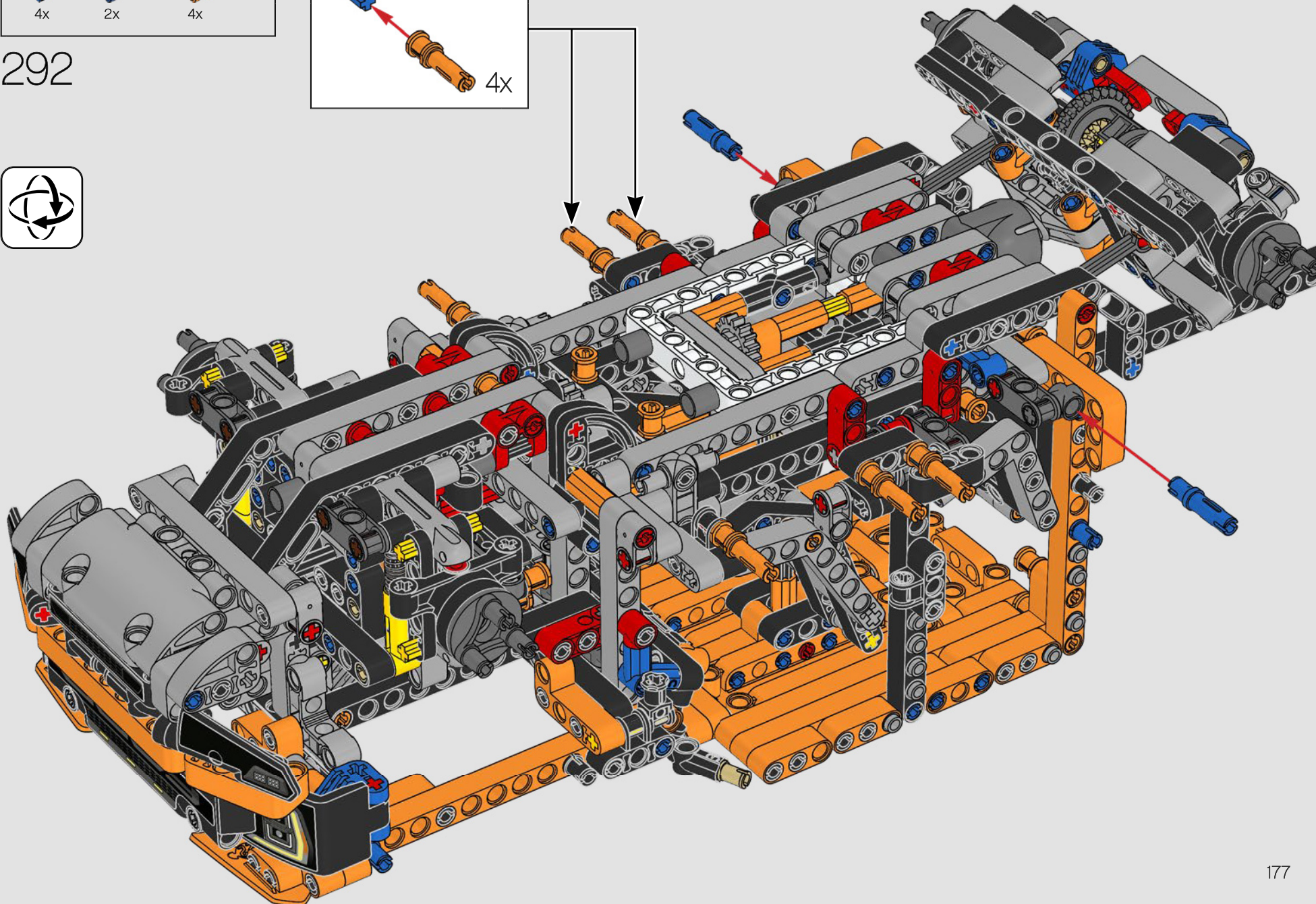
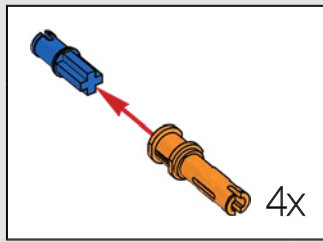

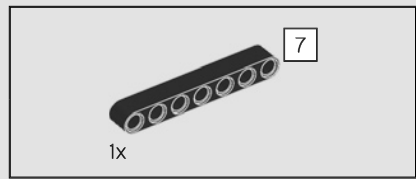

293

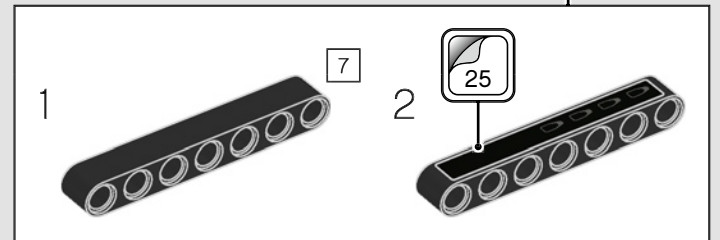
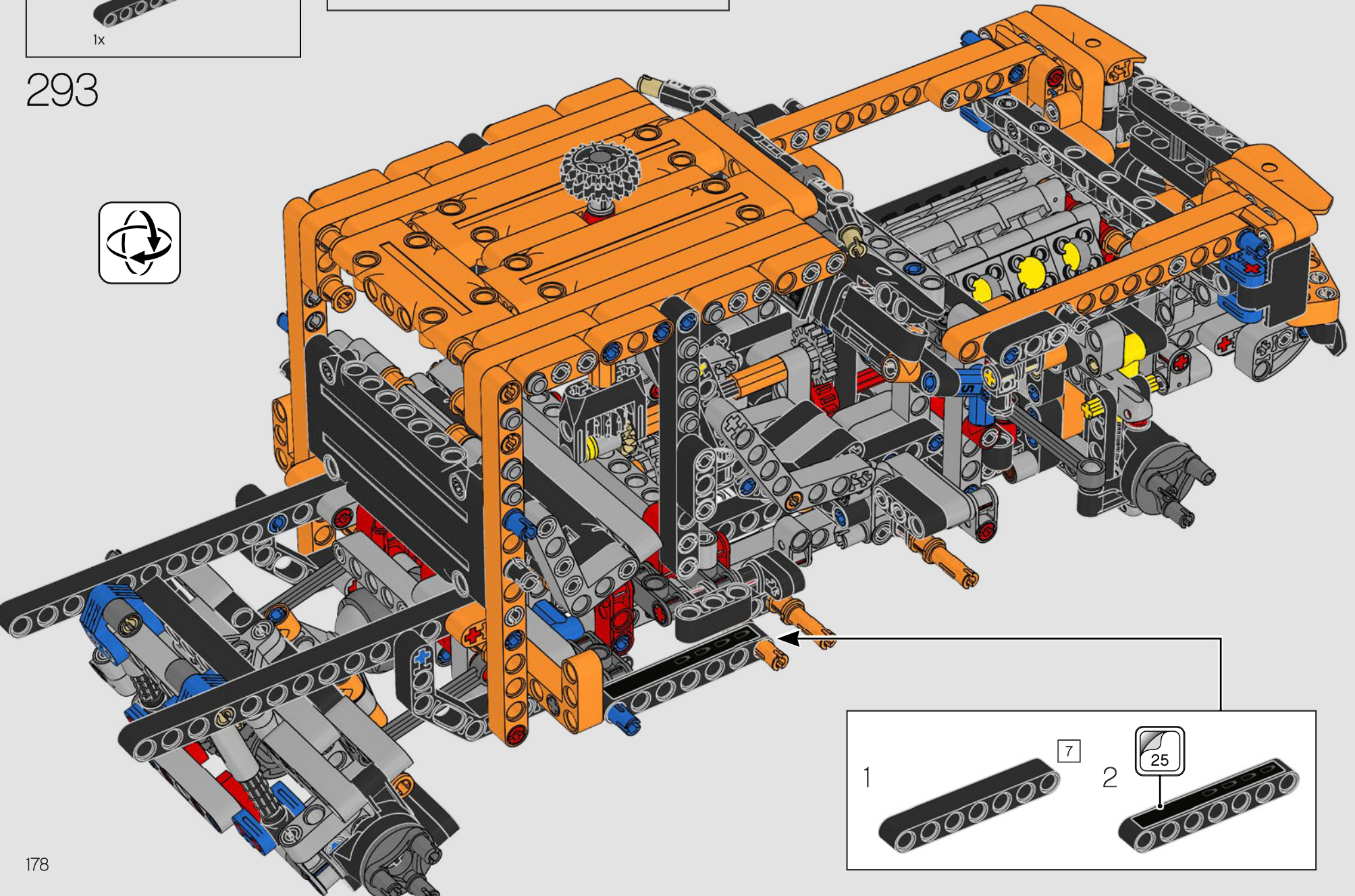

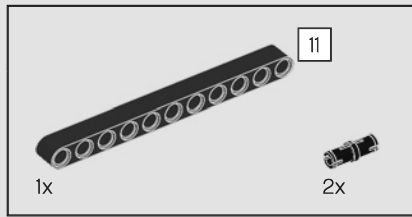

294

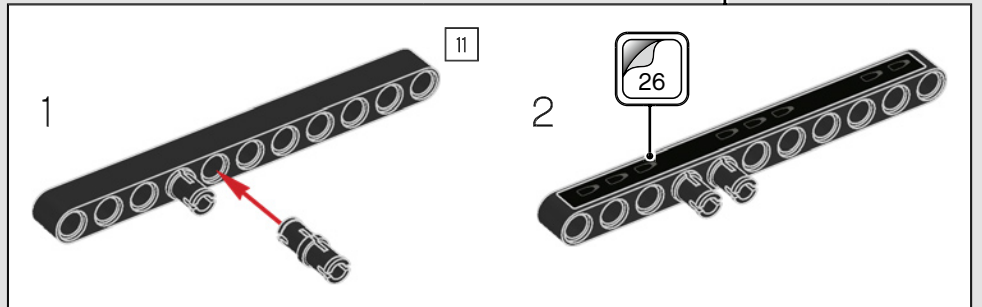
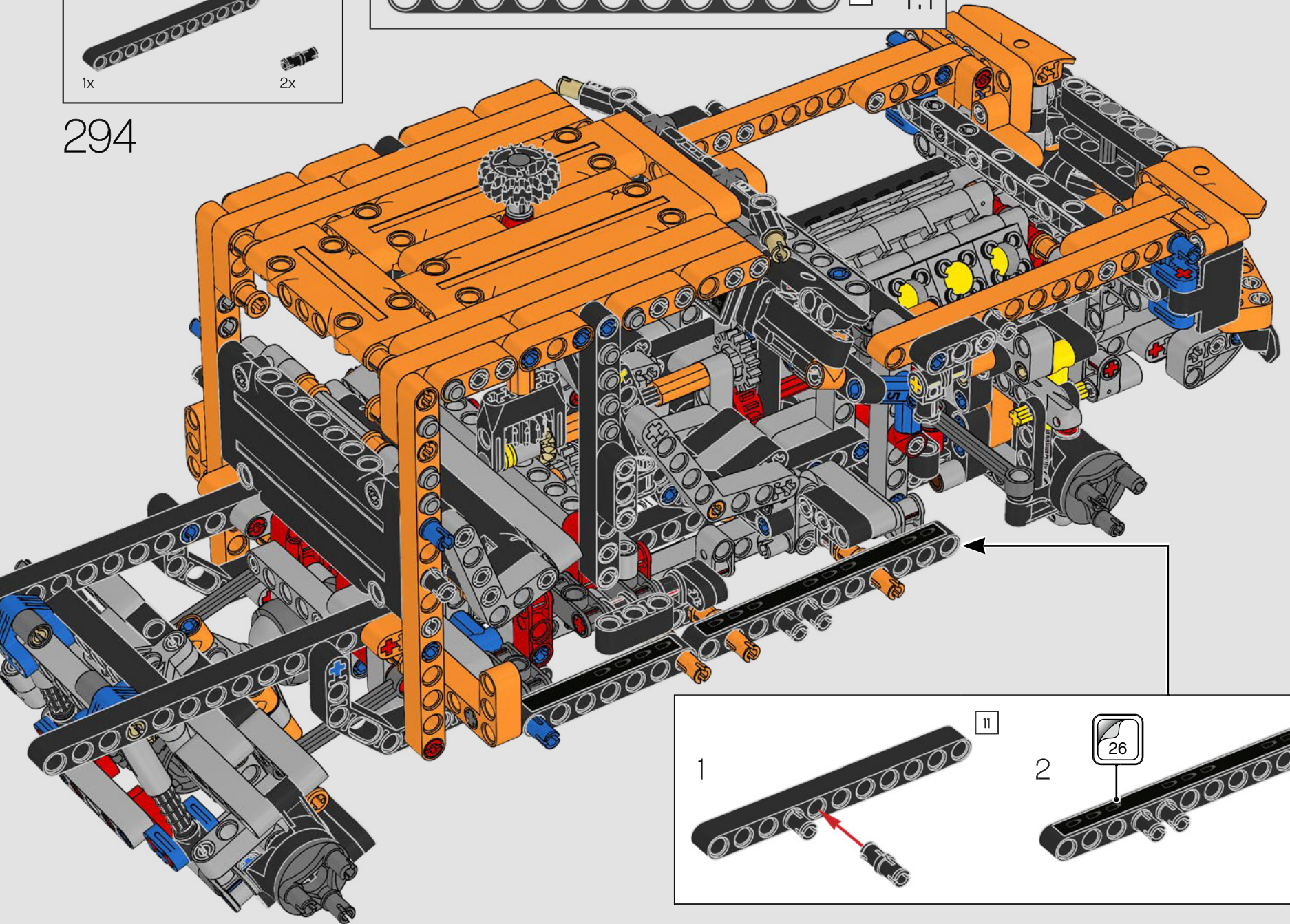

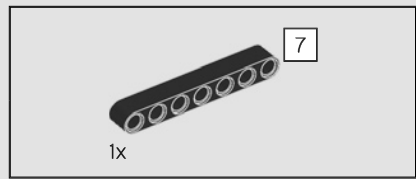

295

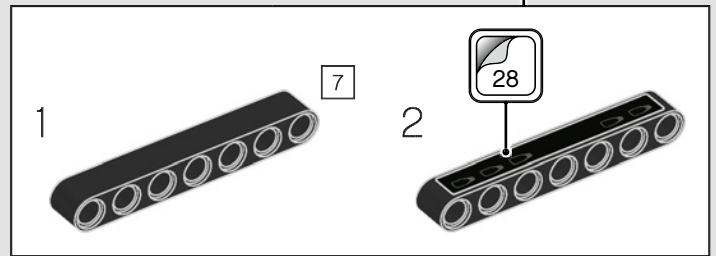
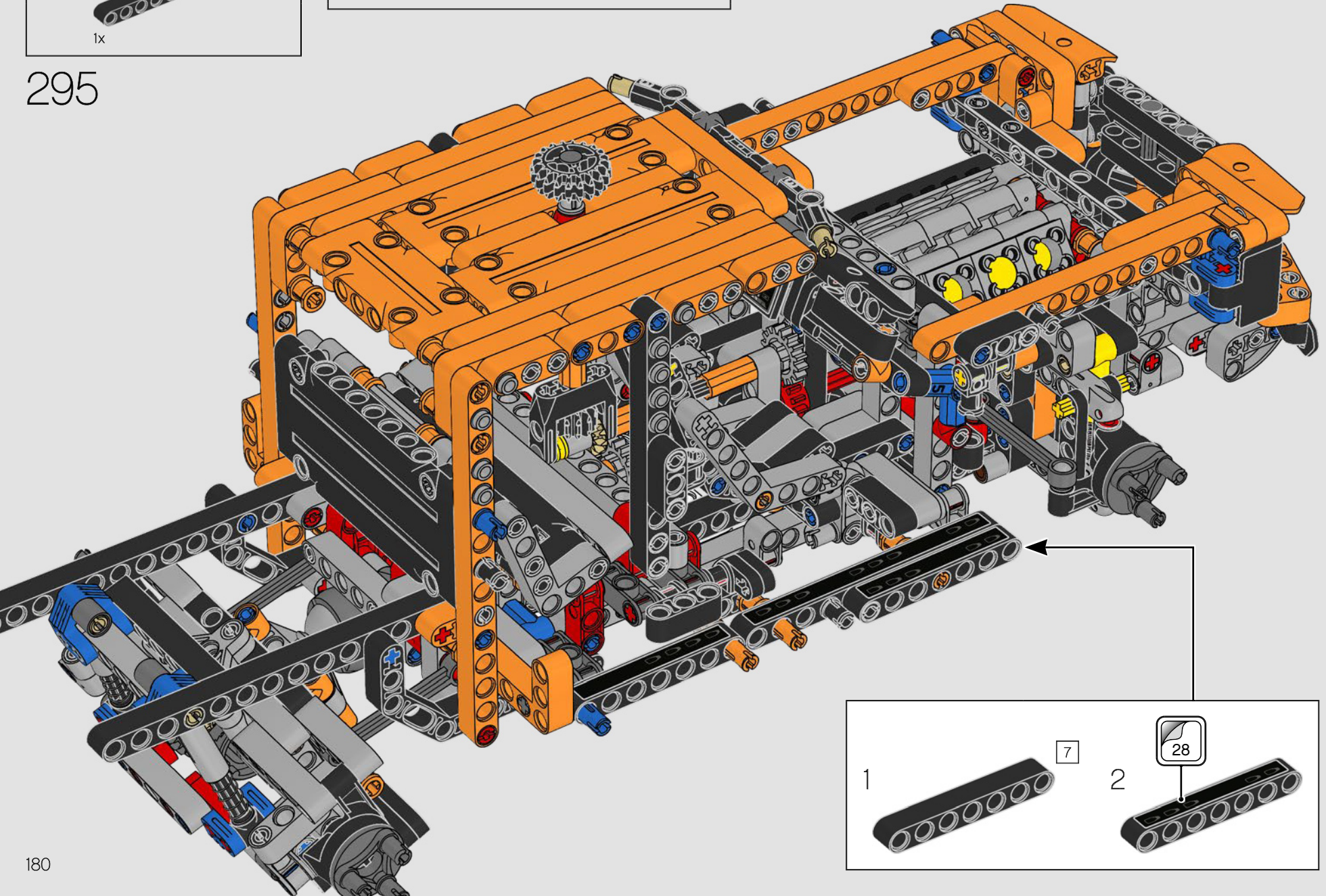

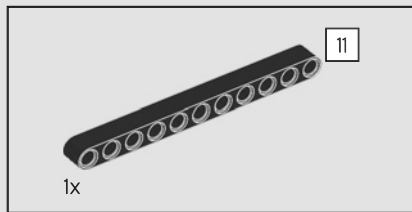

296

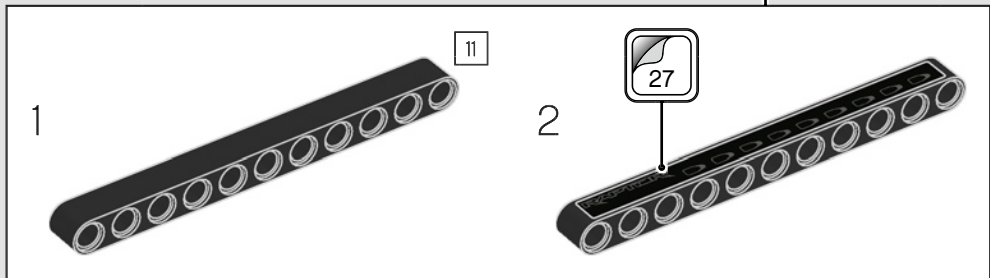
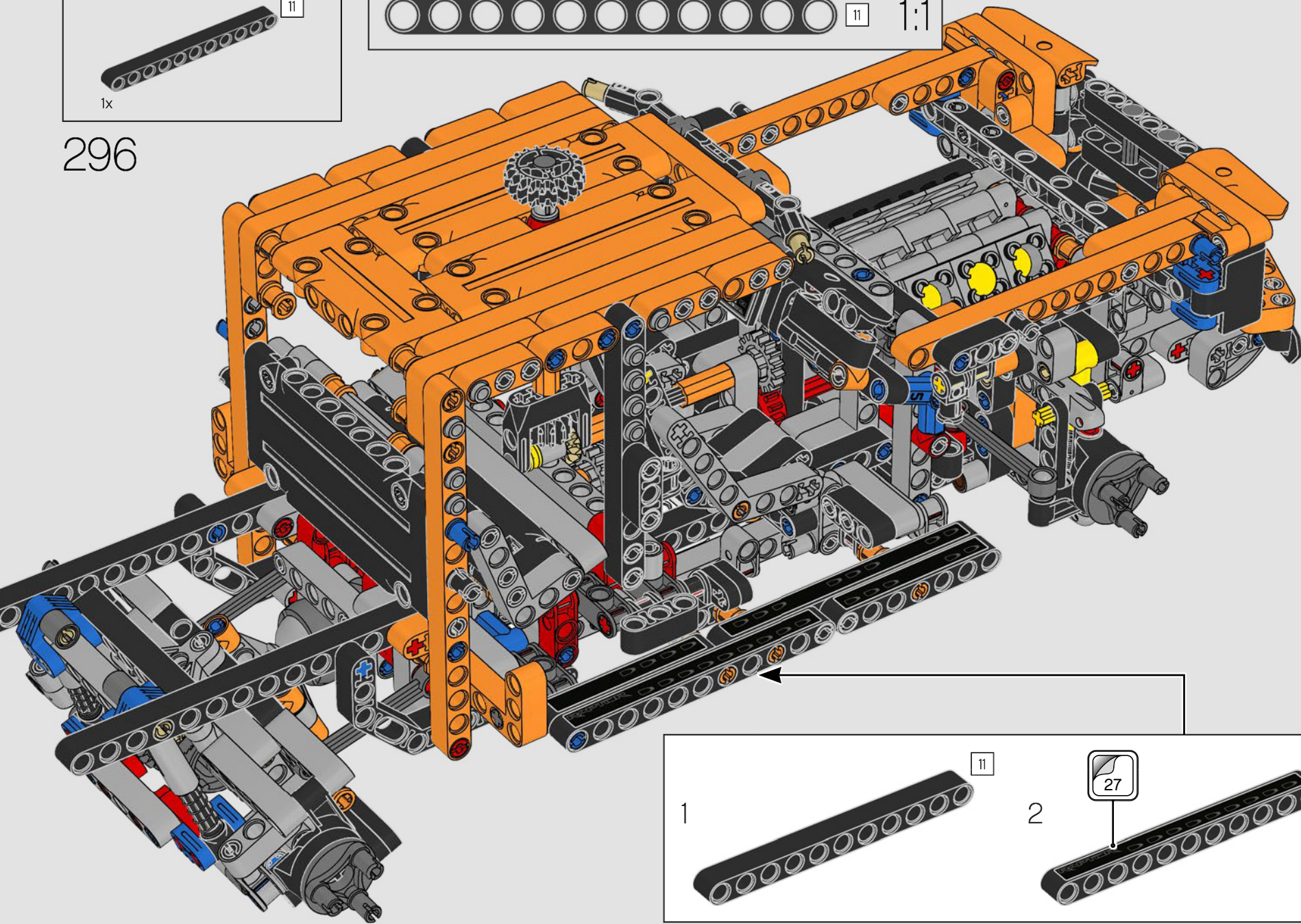

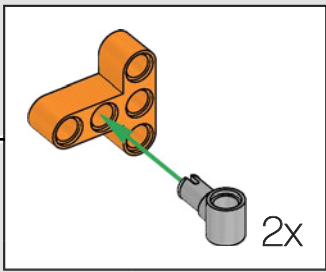
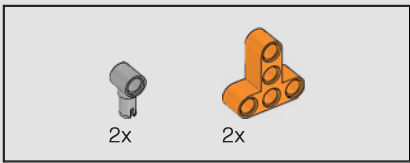

297

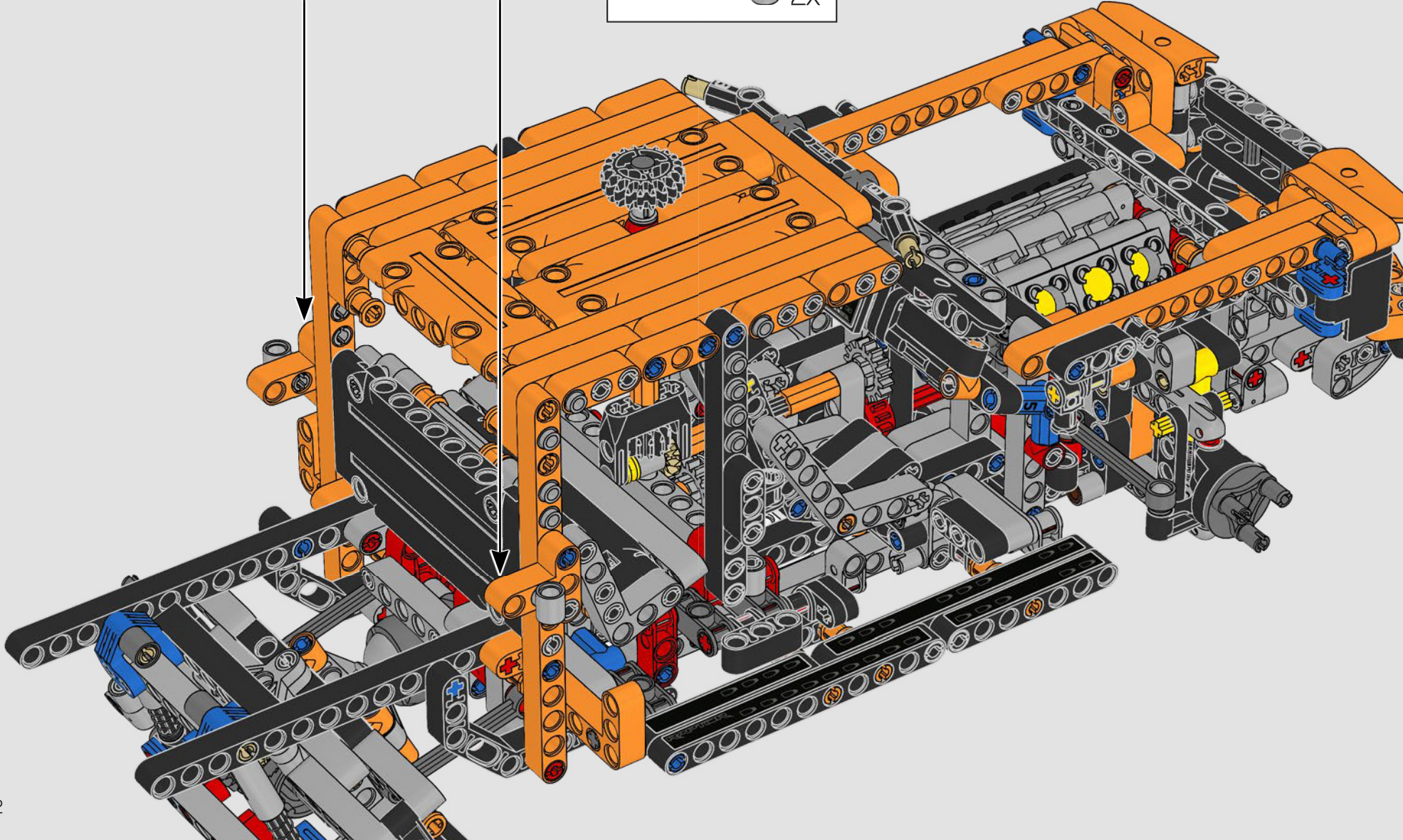

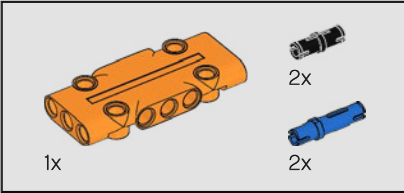
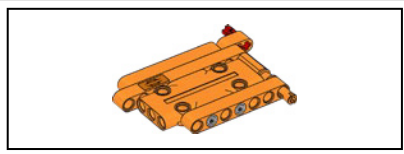

298

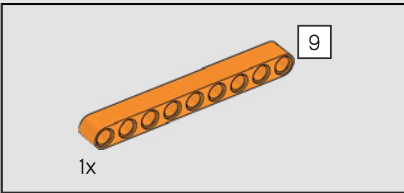
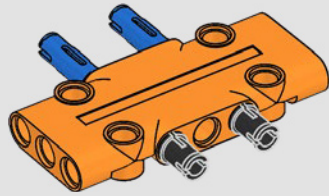

299

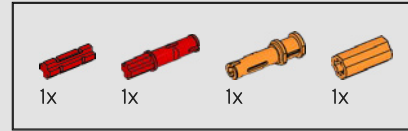
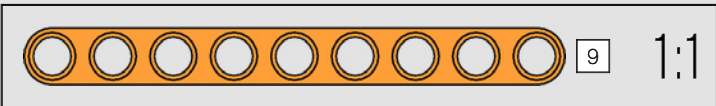
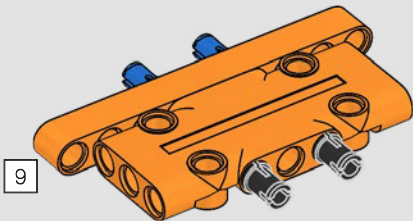

300

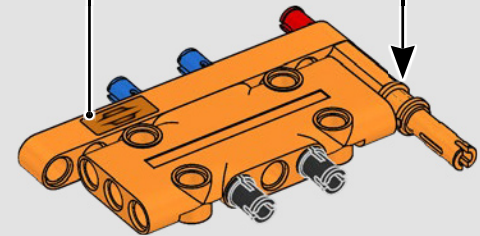
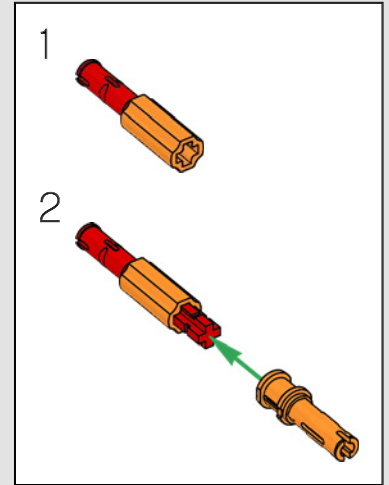

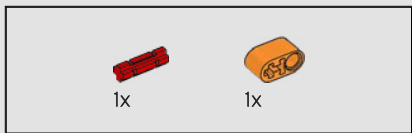

301

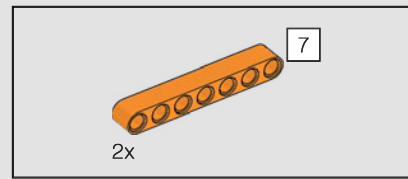
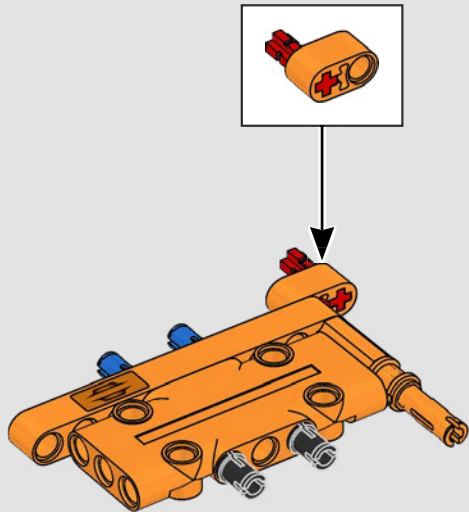

302

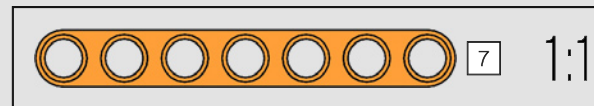
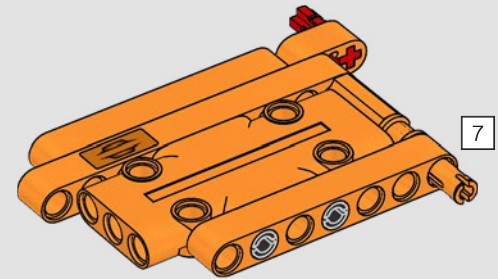



303

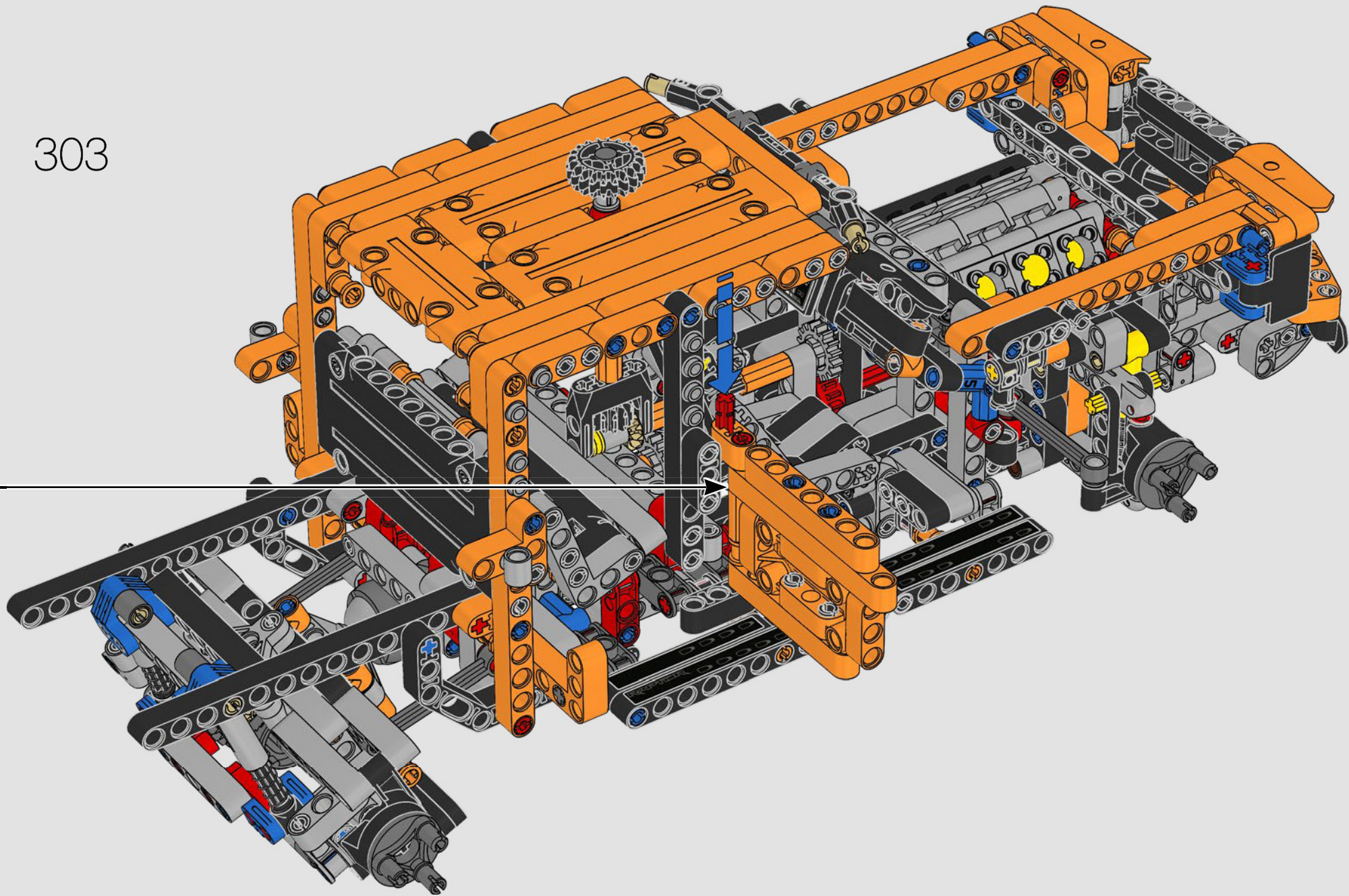

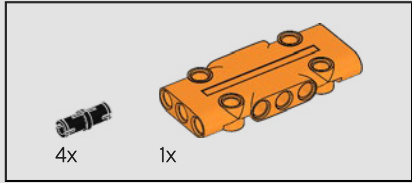
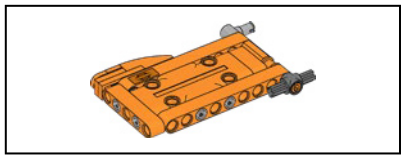

304

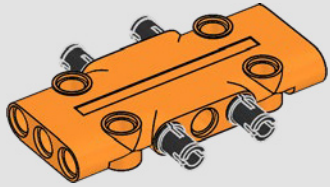

305

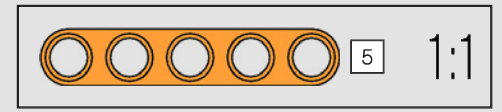
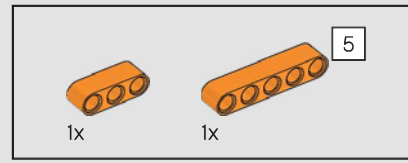
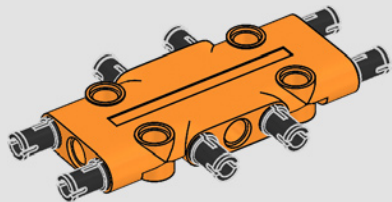

306

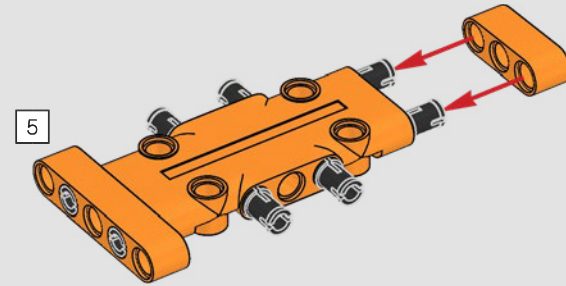

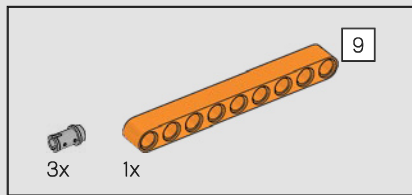

307

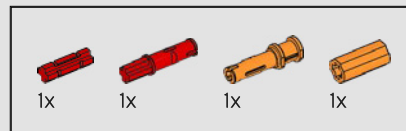
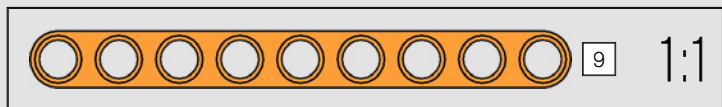
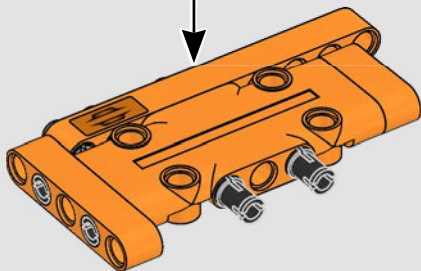
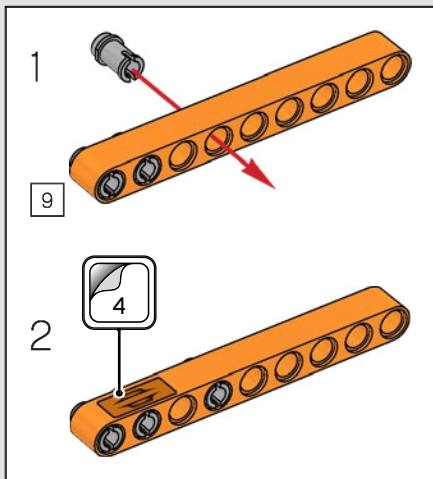

308

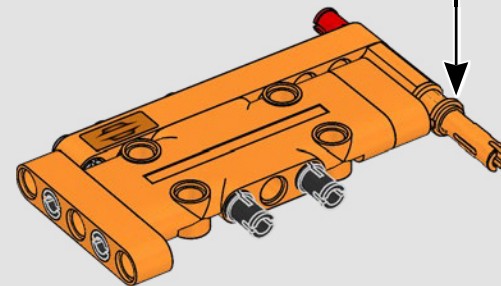
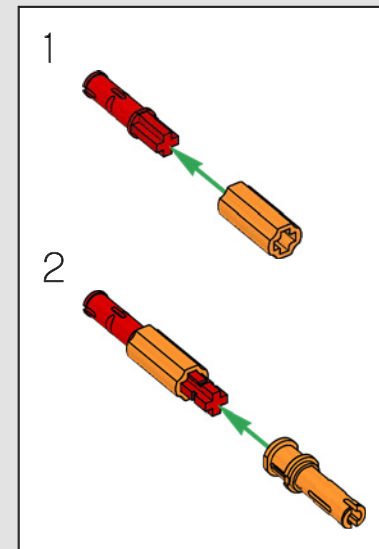

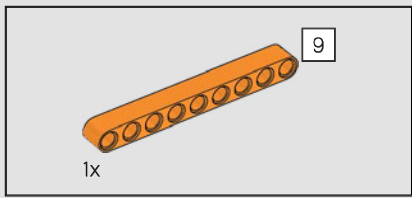

309

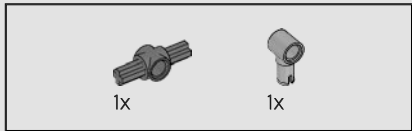
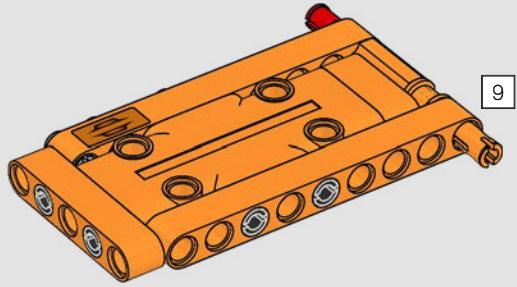

310

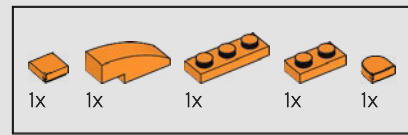
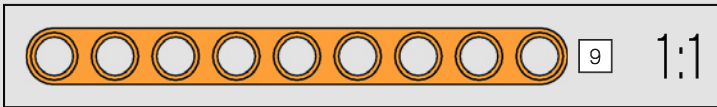
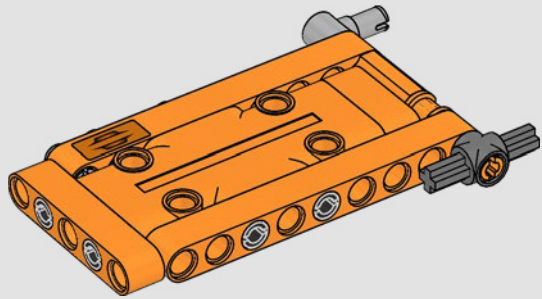

311

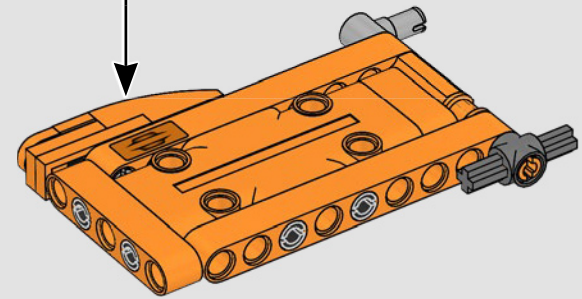
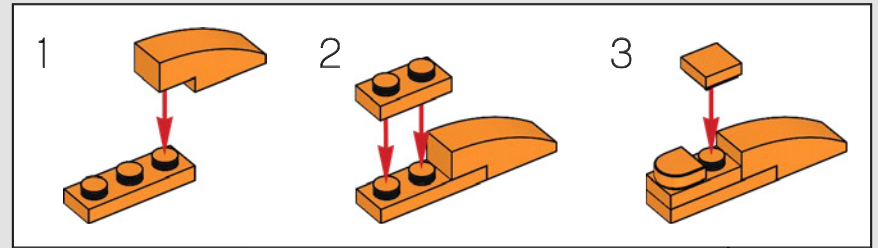

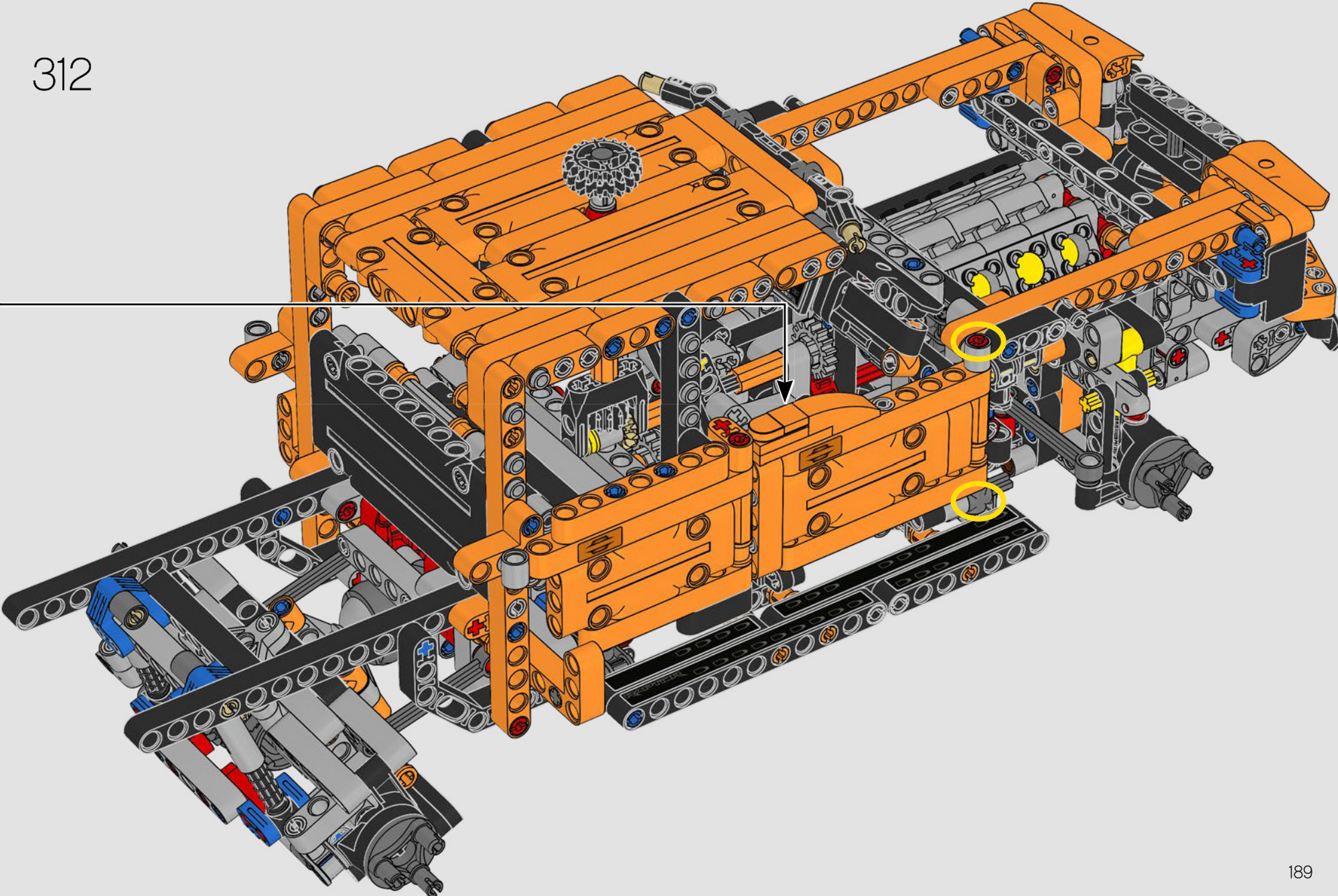

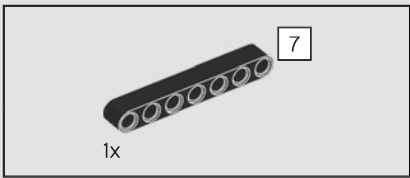

313

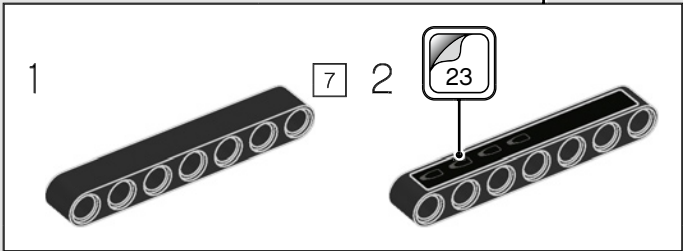
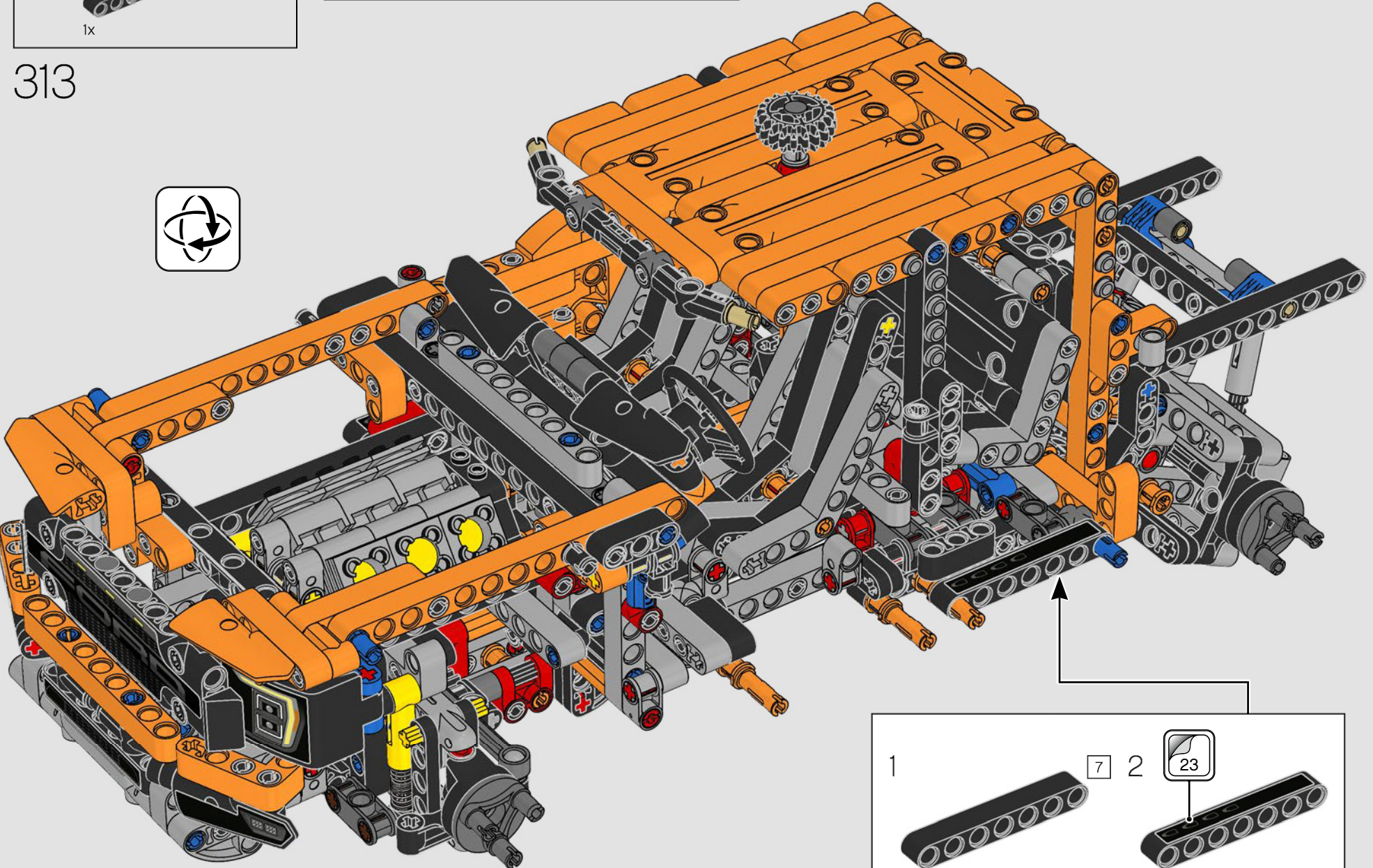

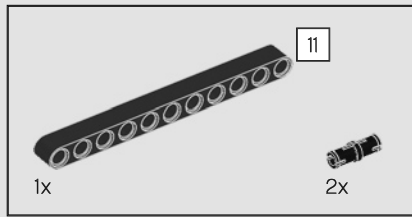

314

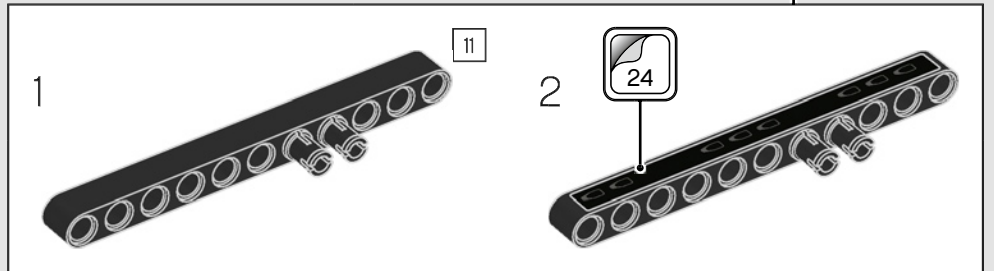
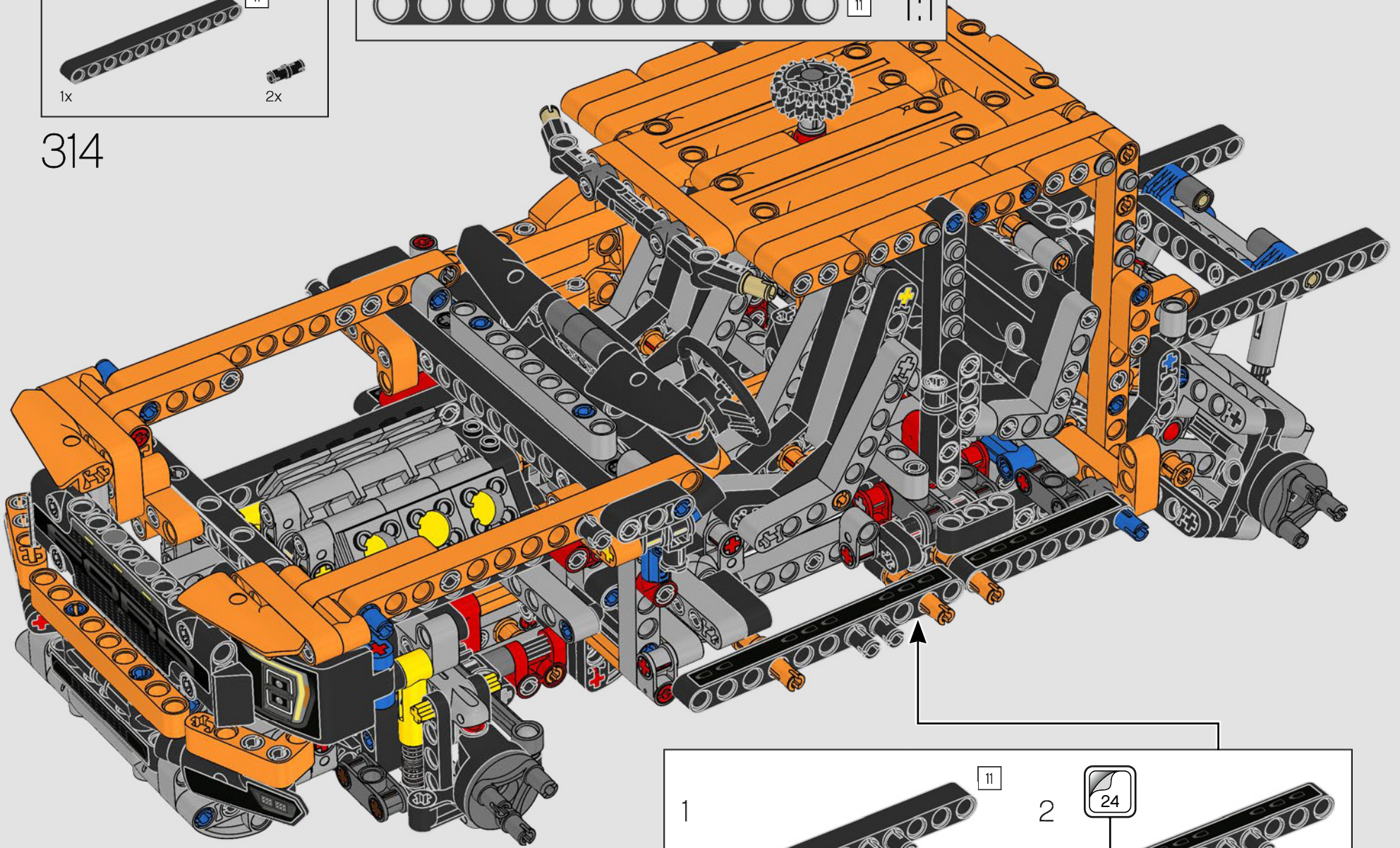

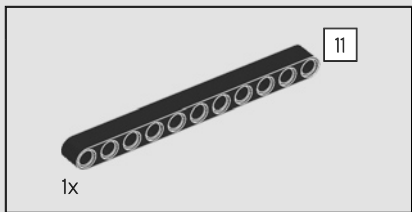

315

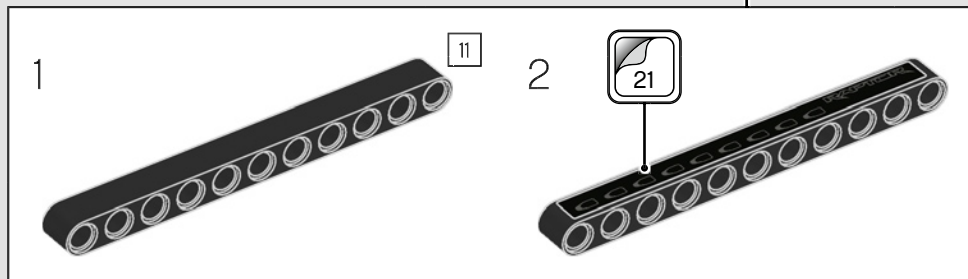
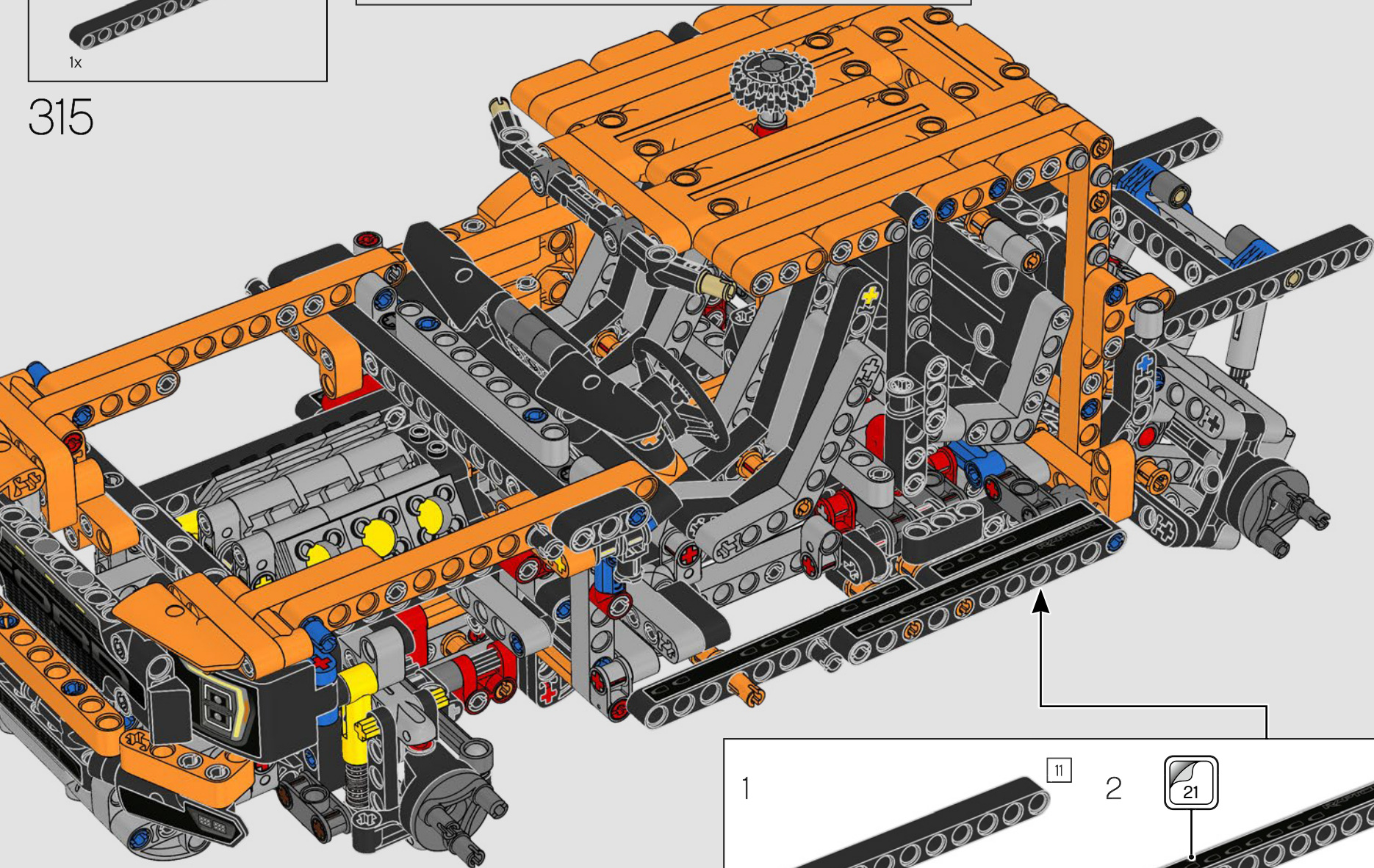



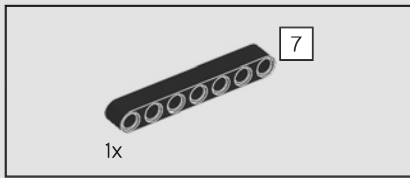

316

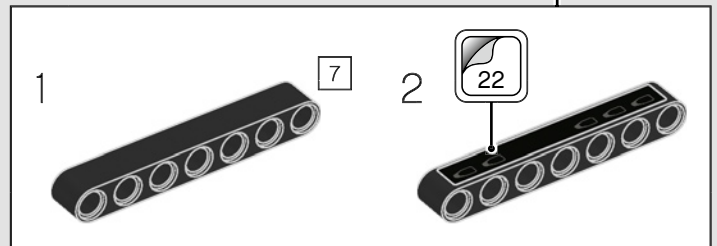
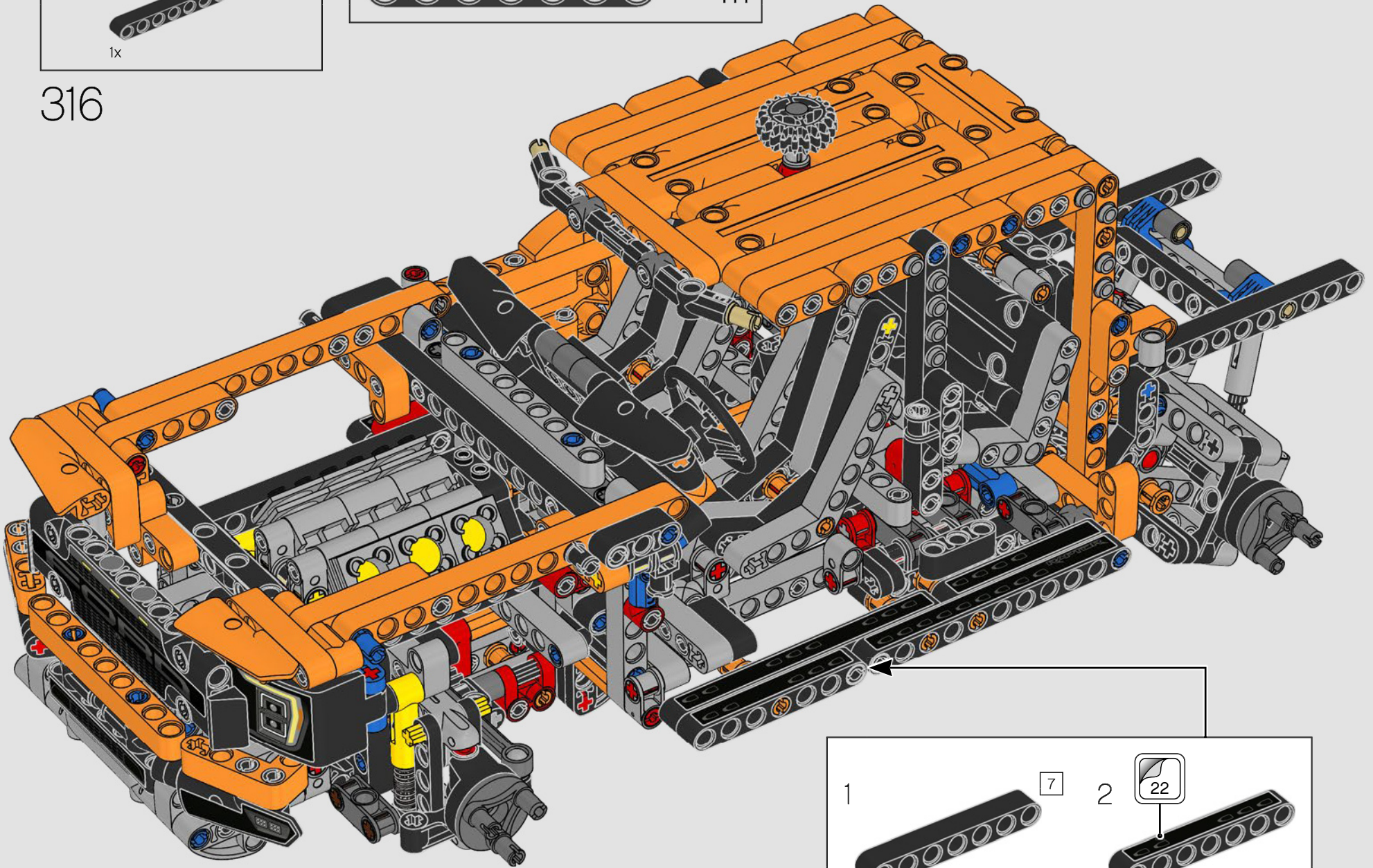

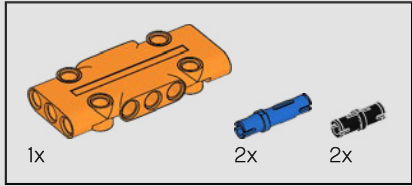
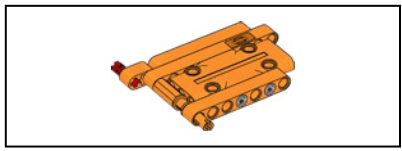

317

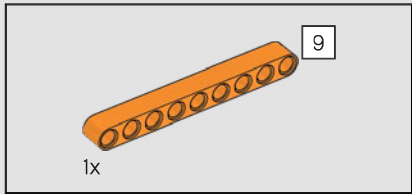
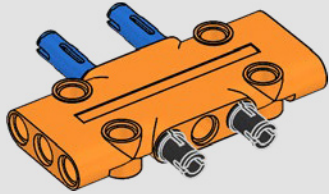

318

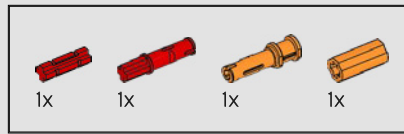
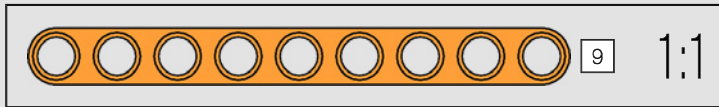
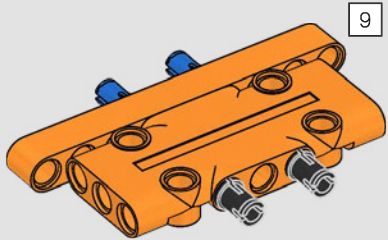

319

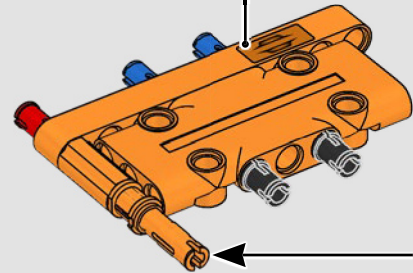
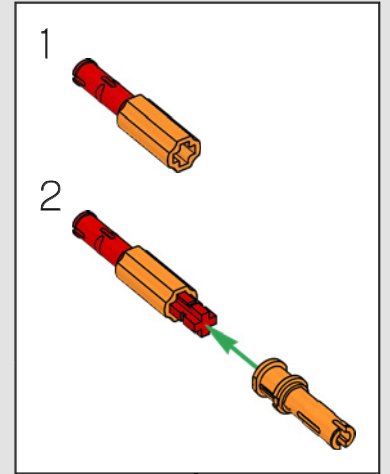

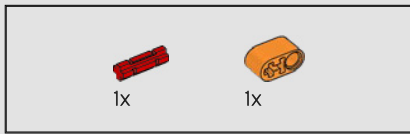

320

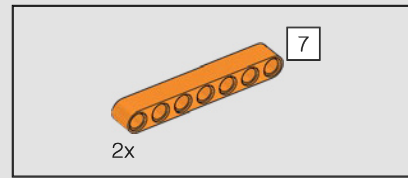
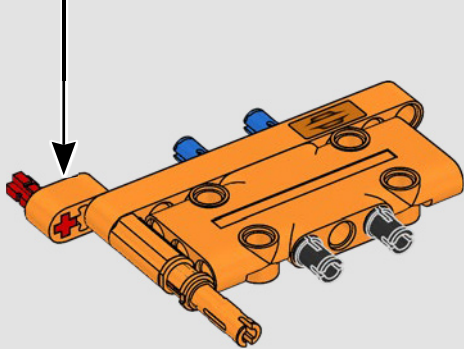
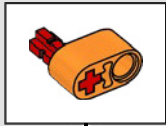

321

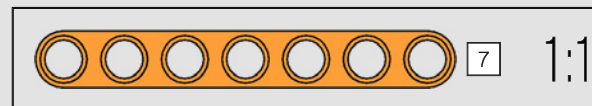
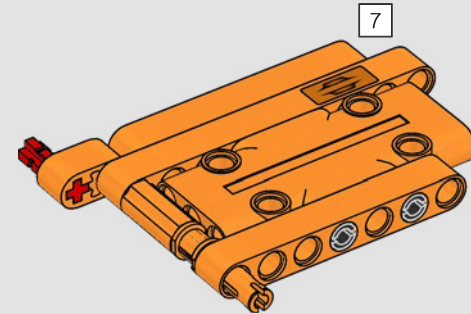

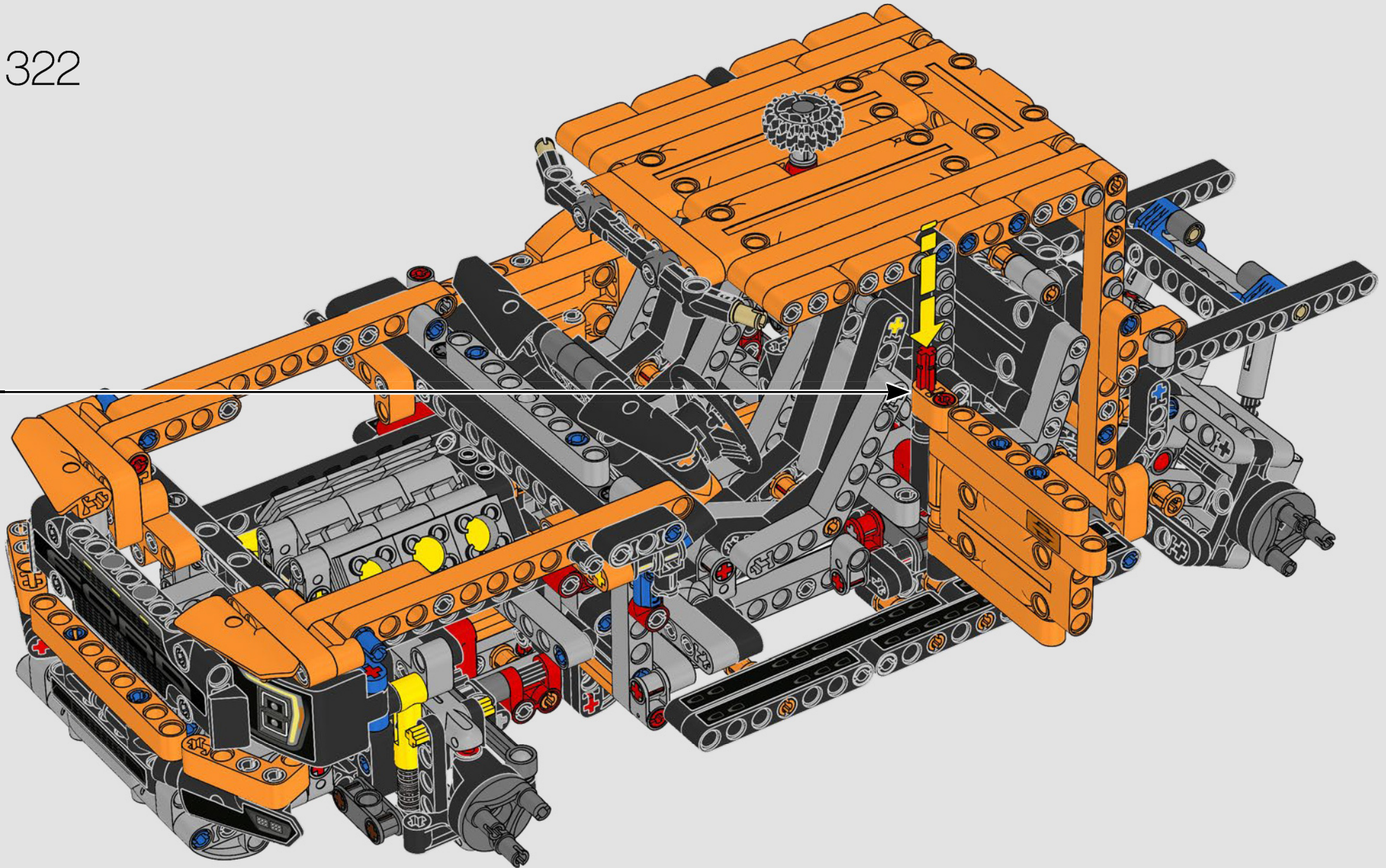

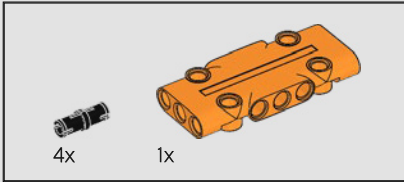
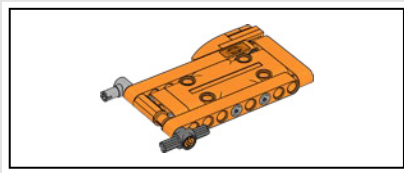

323

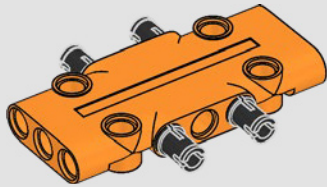

324

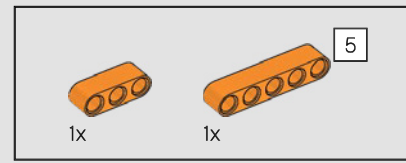
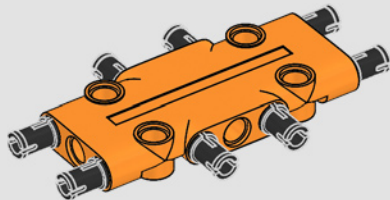

325

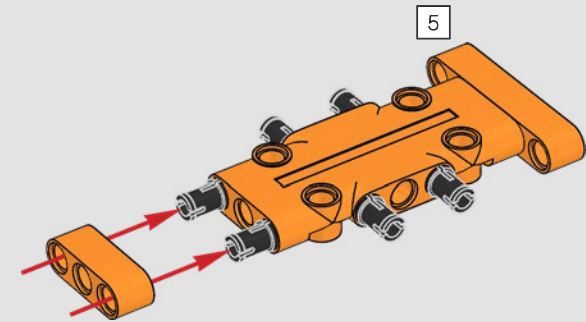
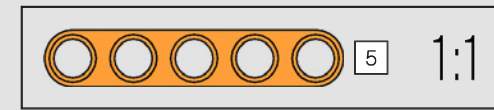

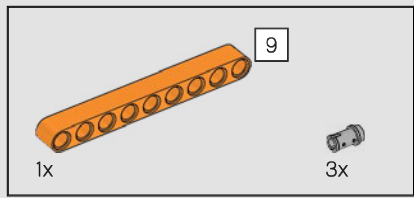

326

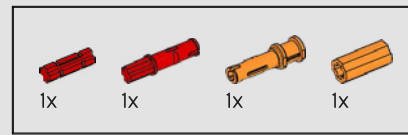
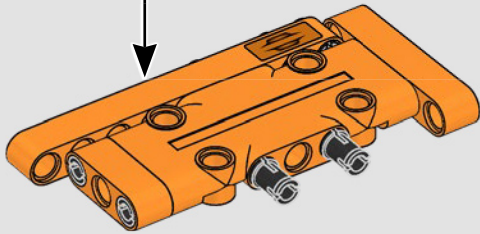
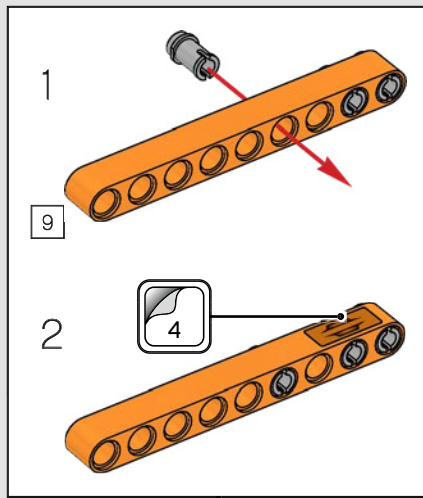

327

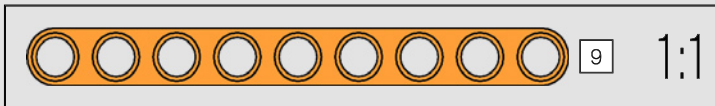
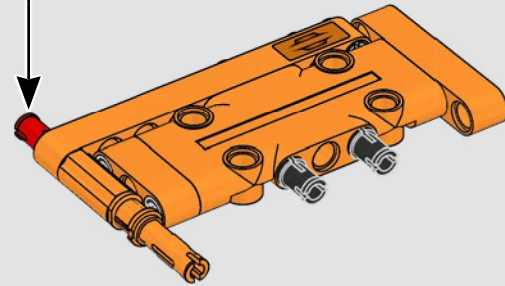
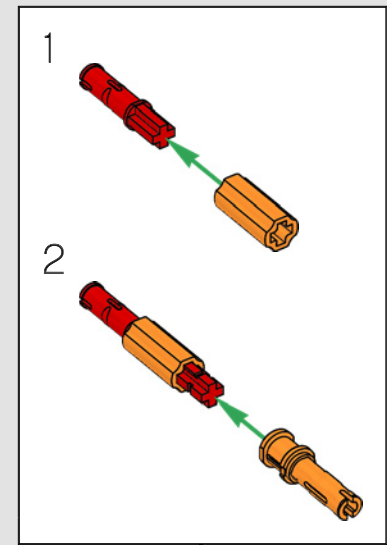

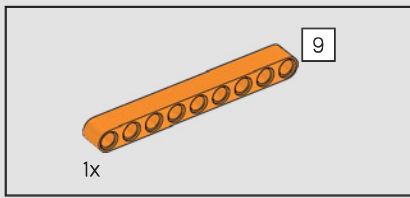

328

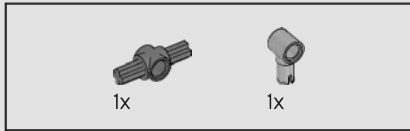
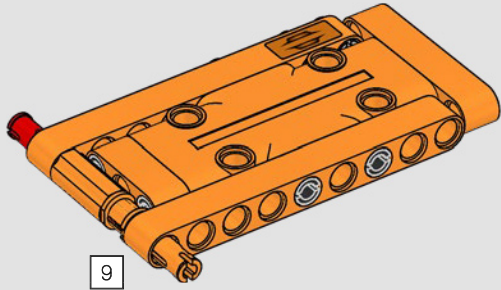

329

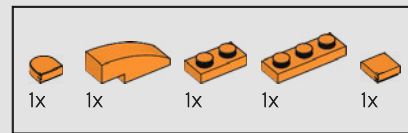
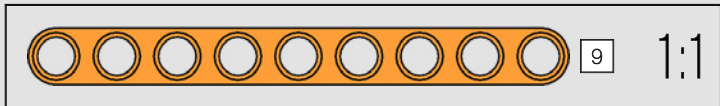
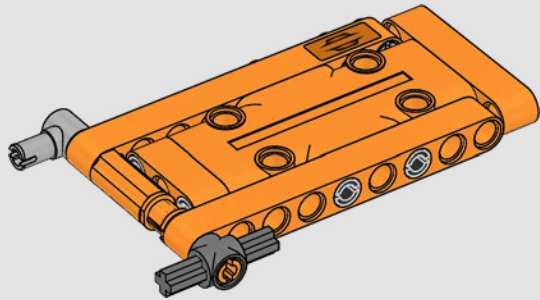

330

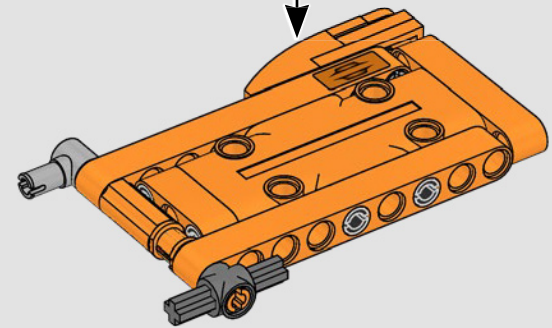
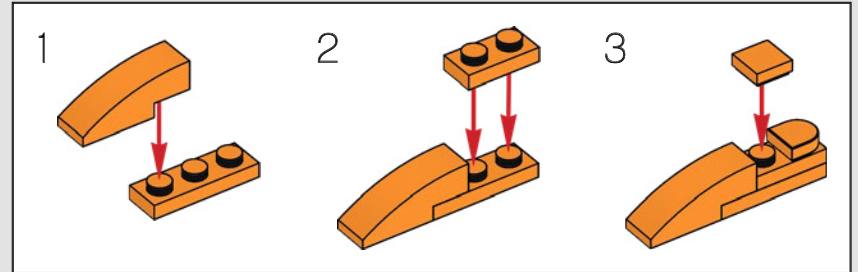

331

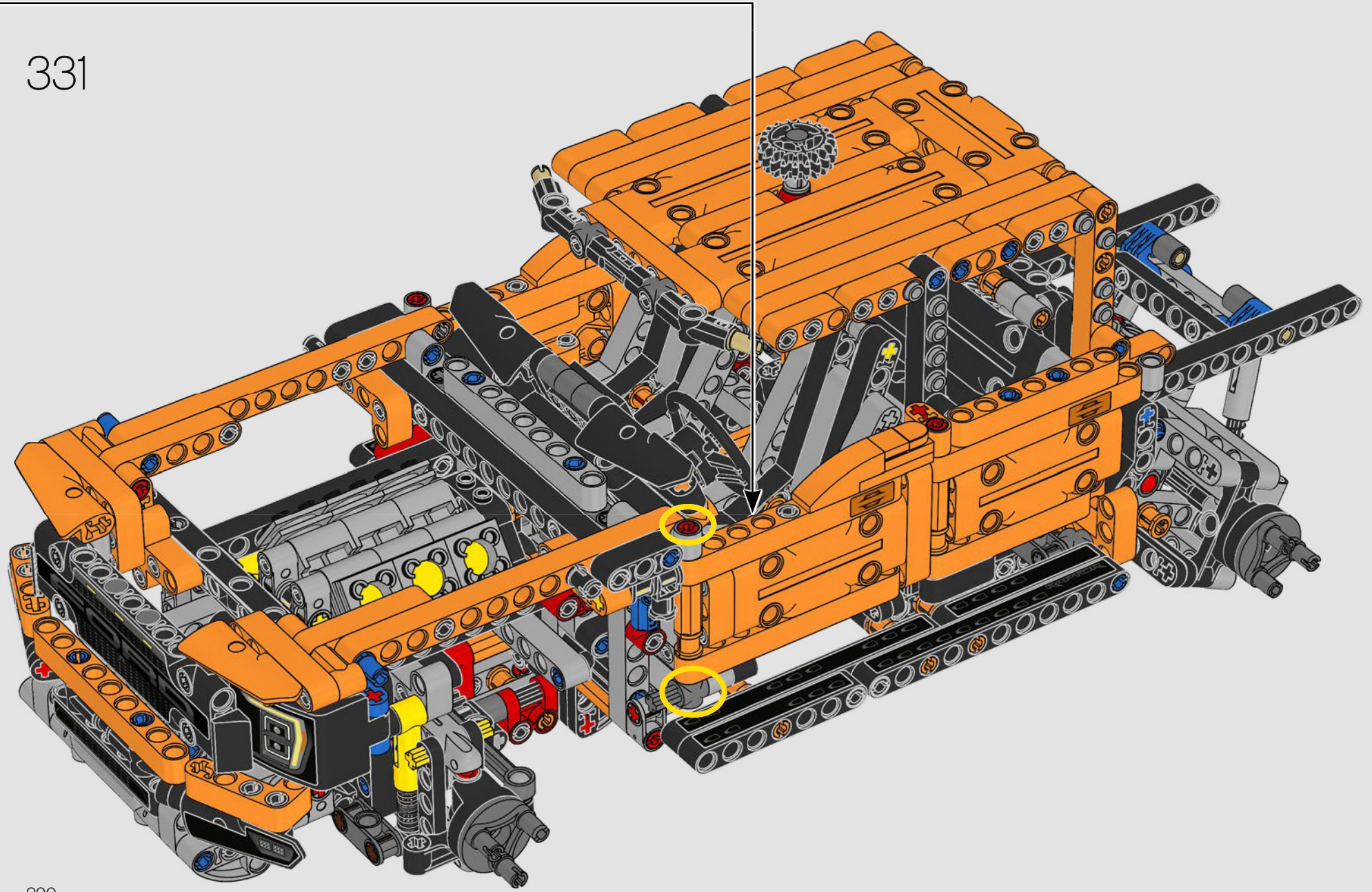



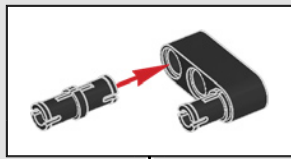
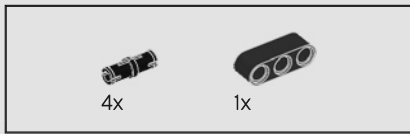

332

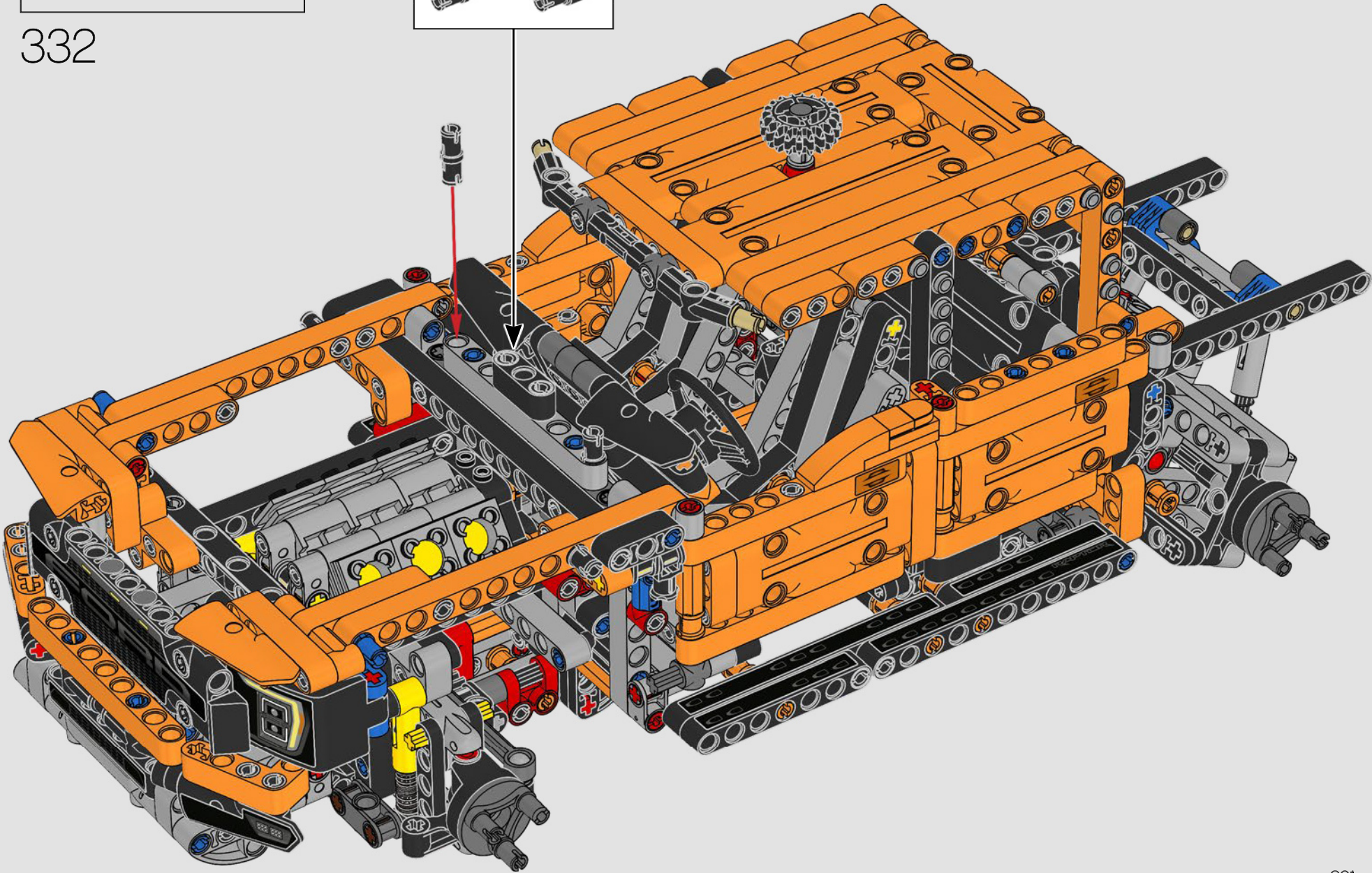

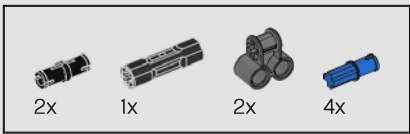

333

1

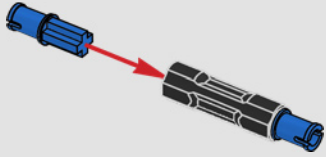

2

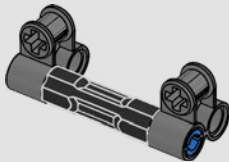

3

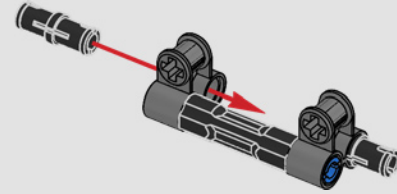

4

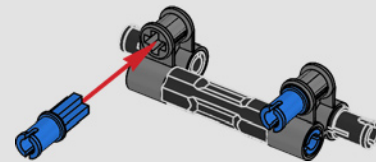

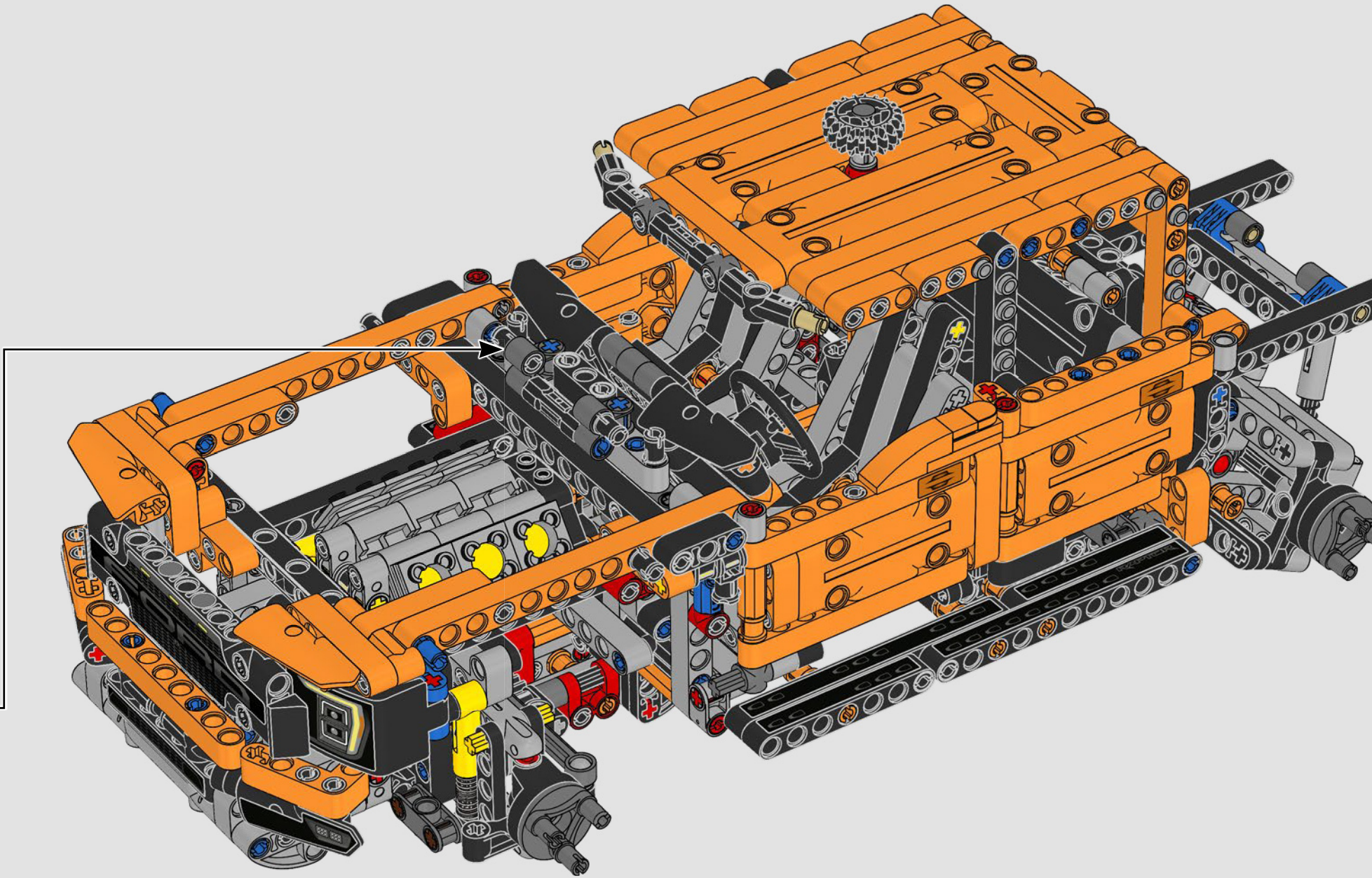

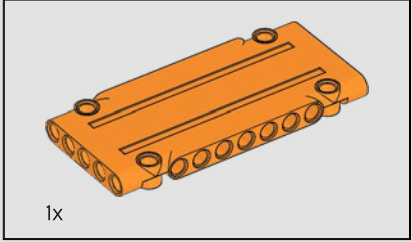
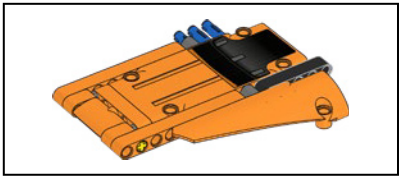

334

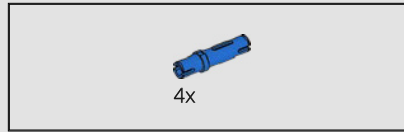
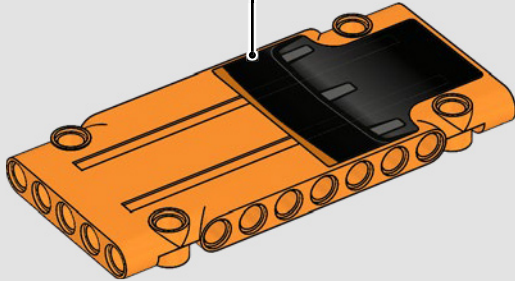

335

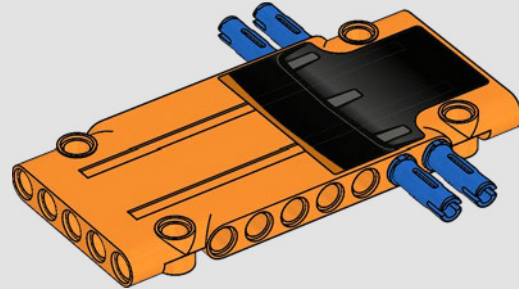

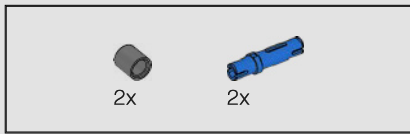

336

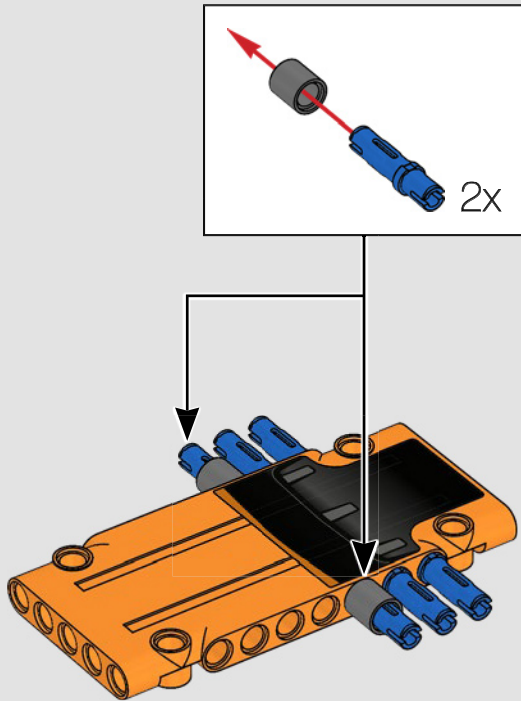

337

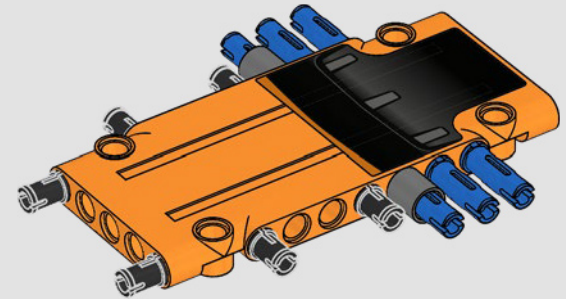

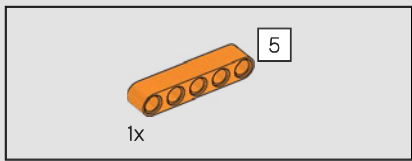

338

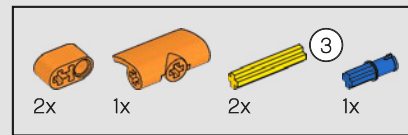
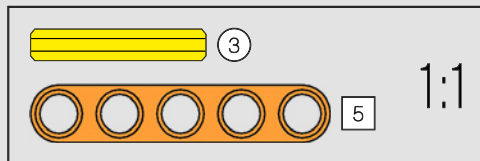
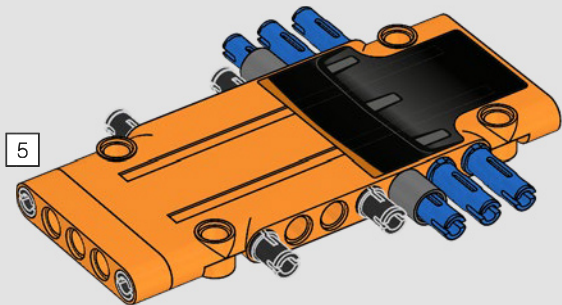

339

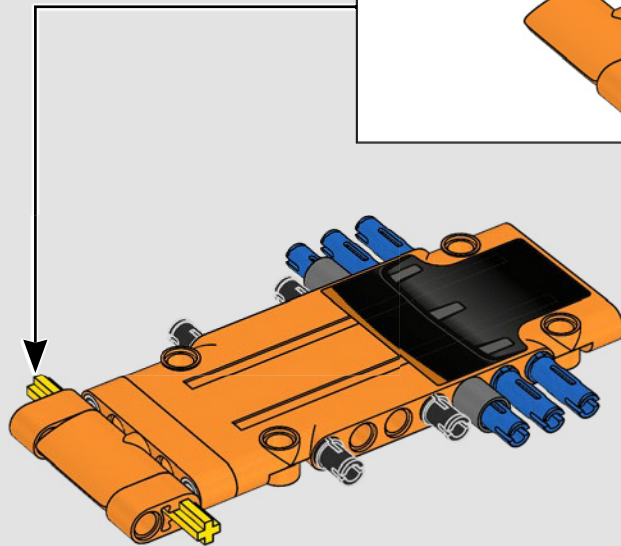
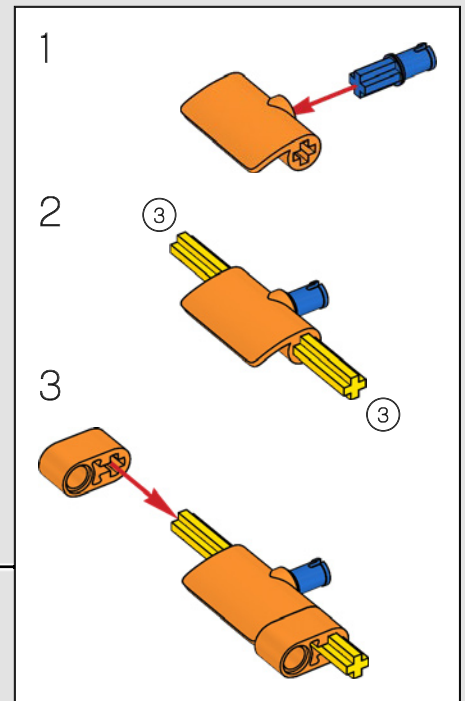

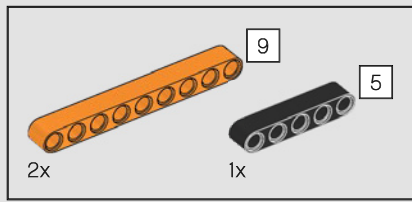

340

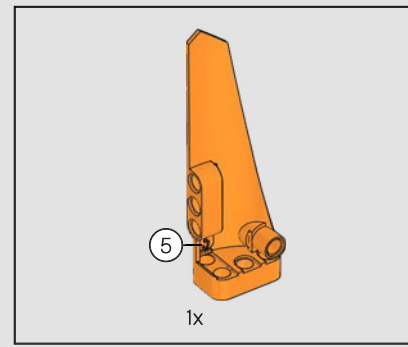
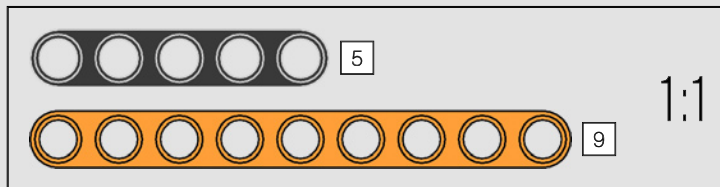
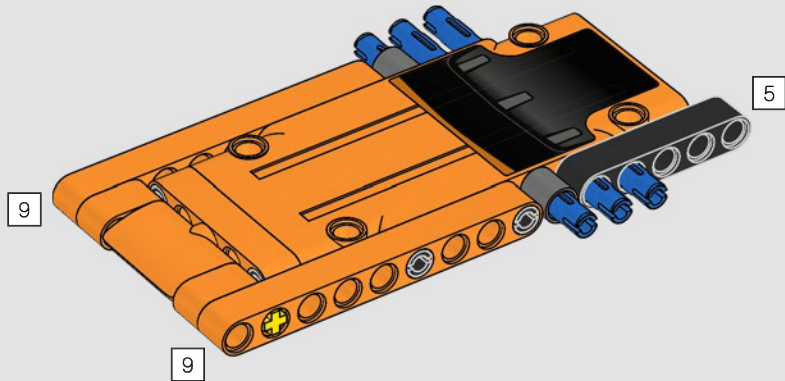

341

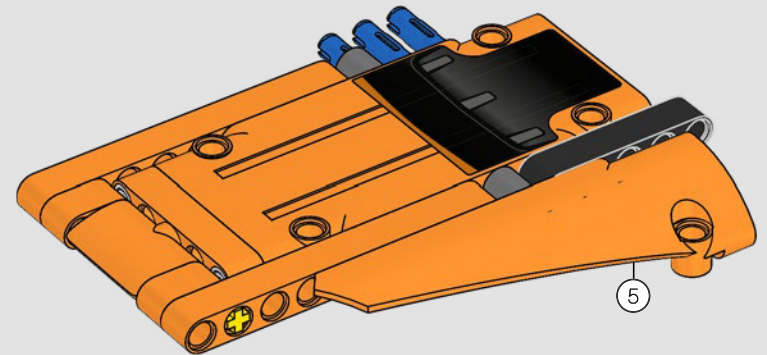

342

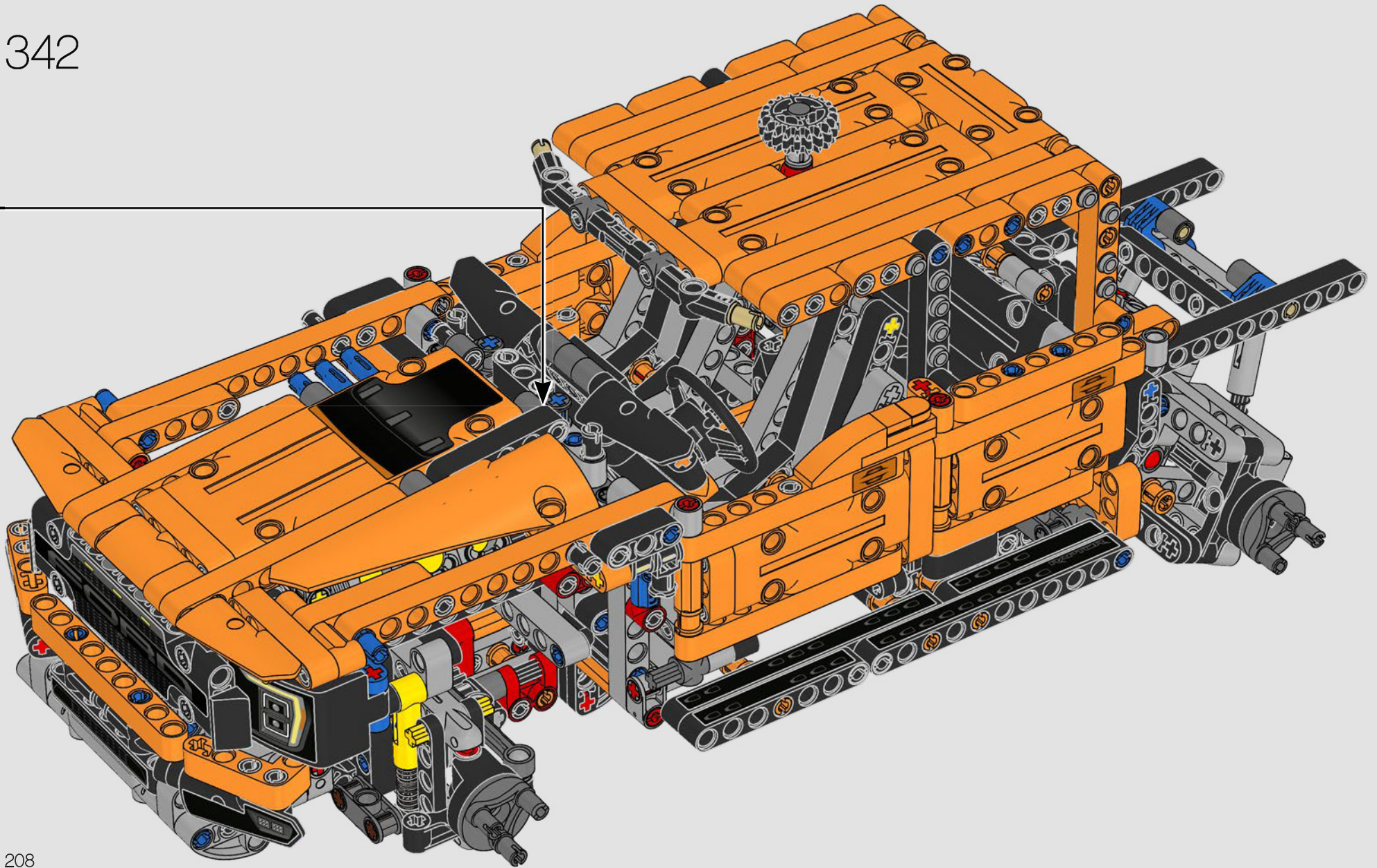



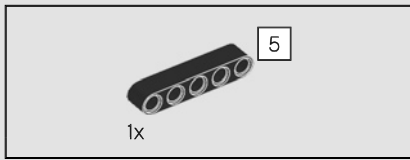

343

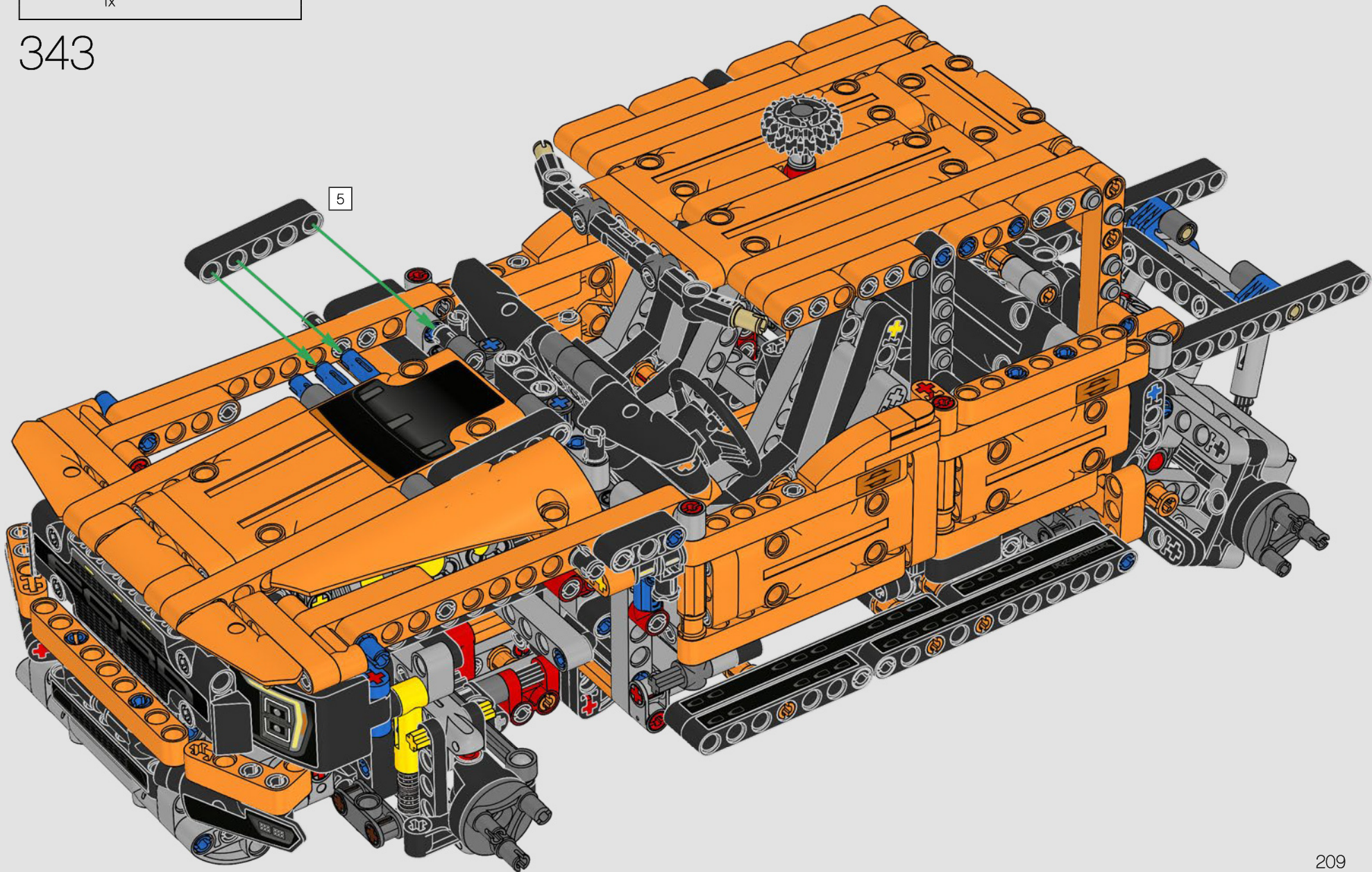

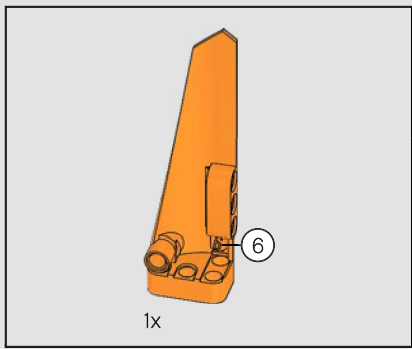

344

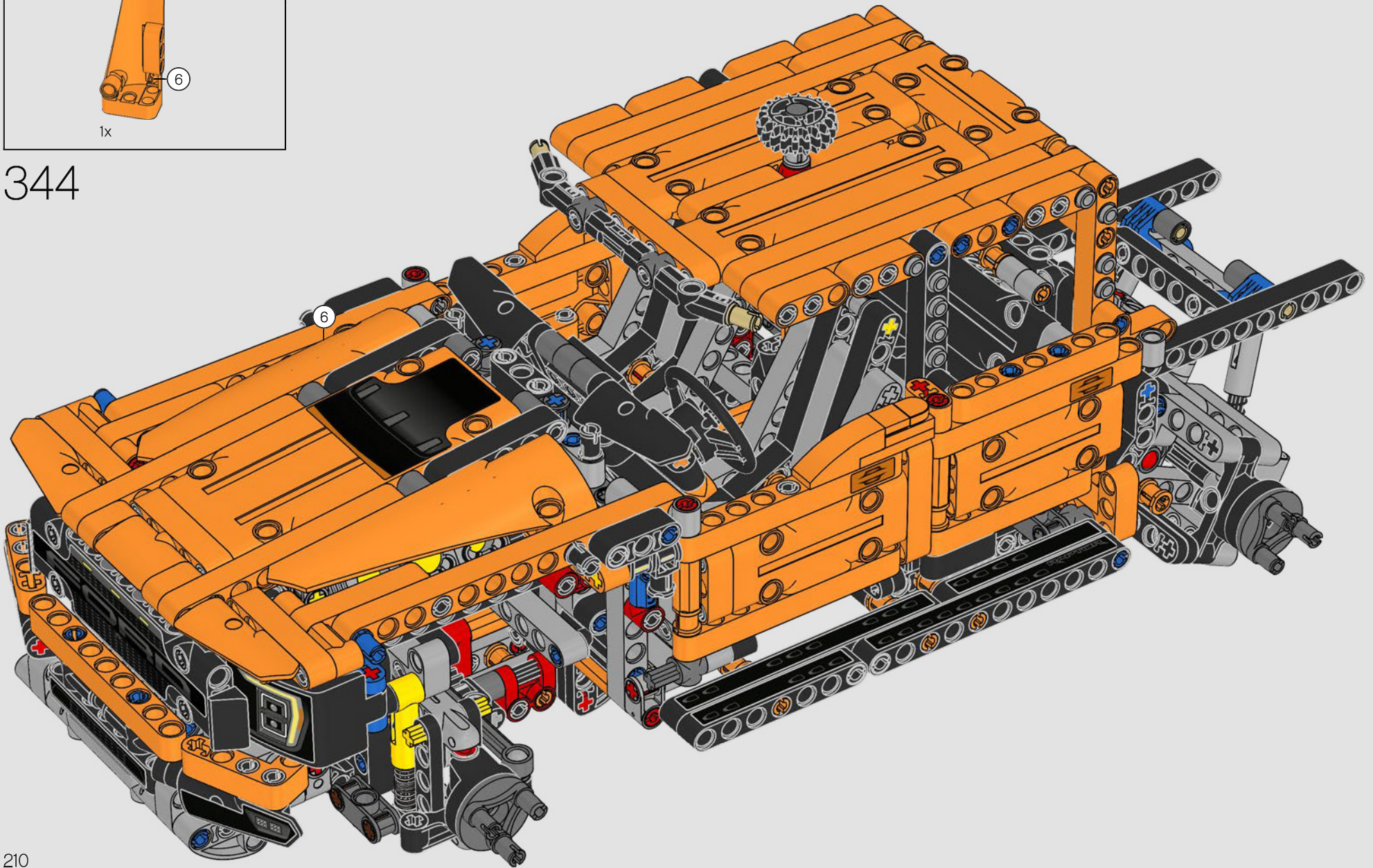

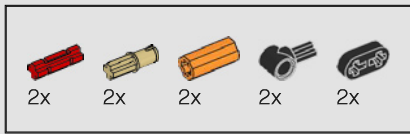

345

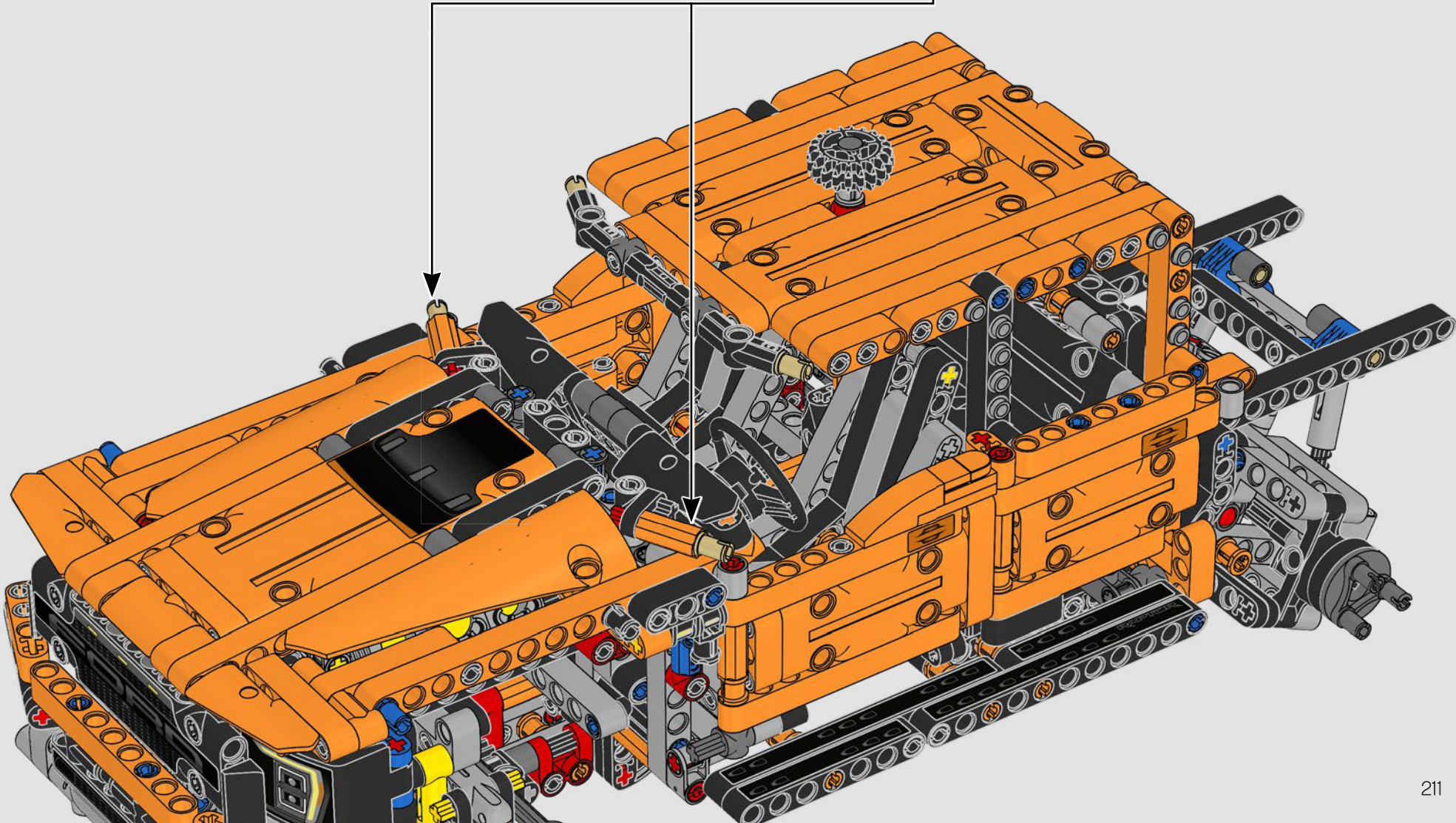
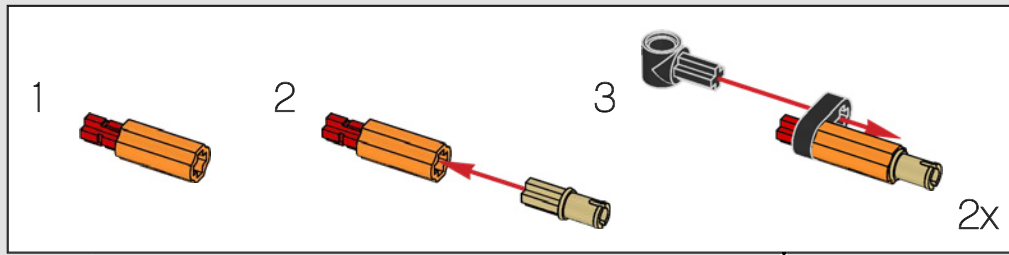

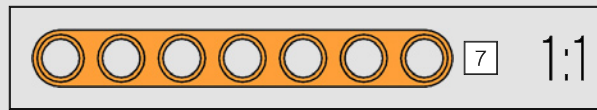
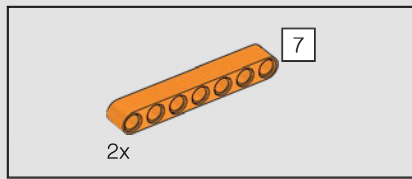

346

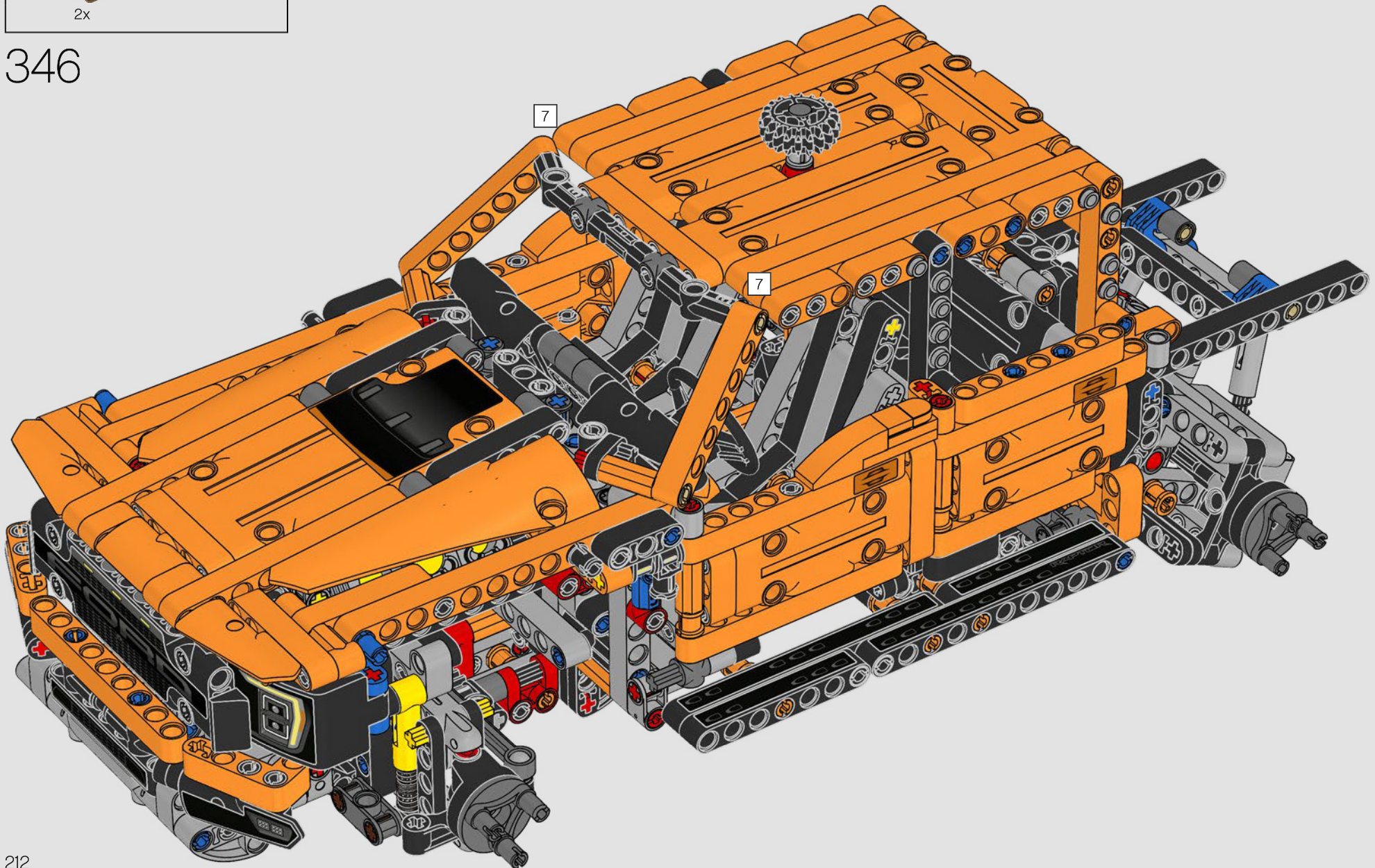

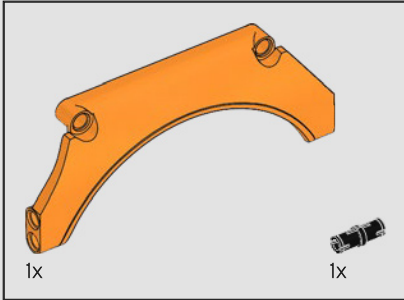
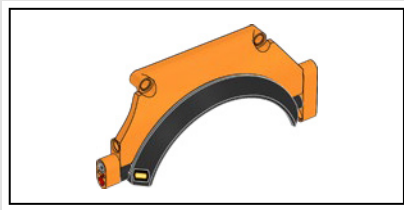

347

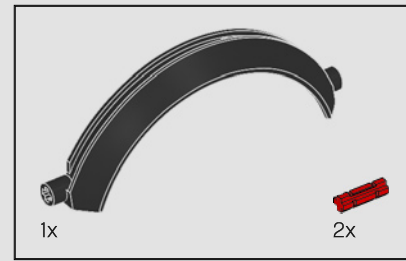
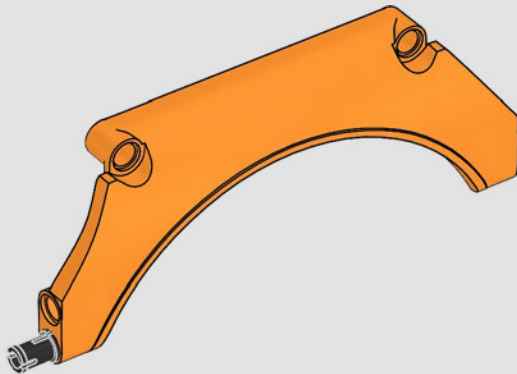

348

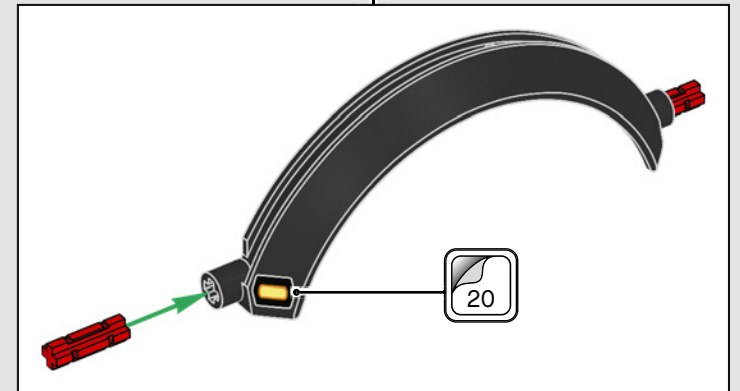
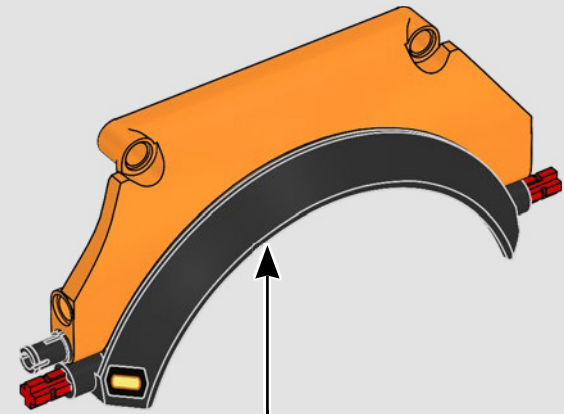

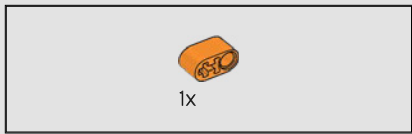

349

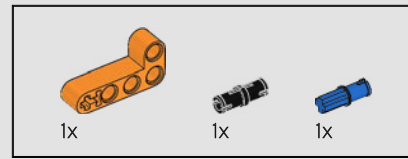
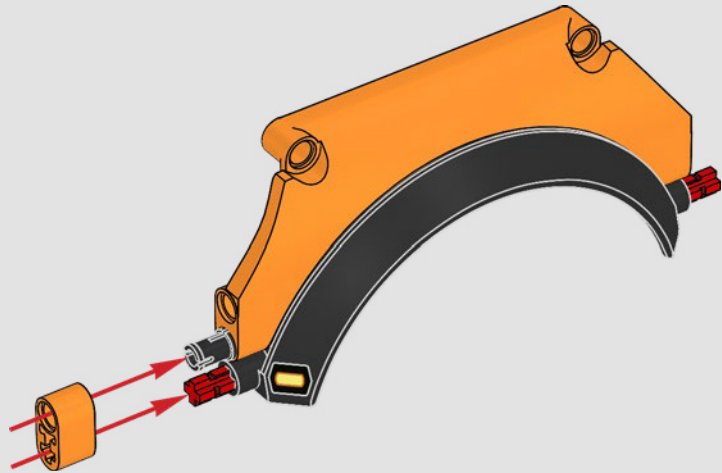

350

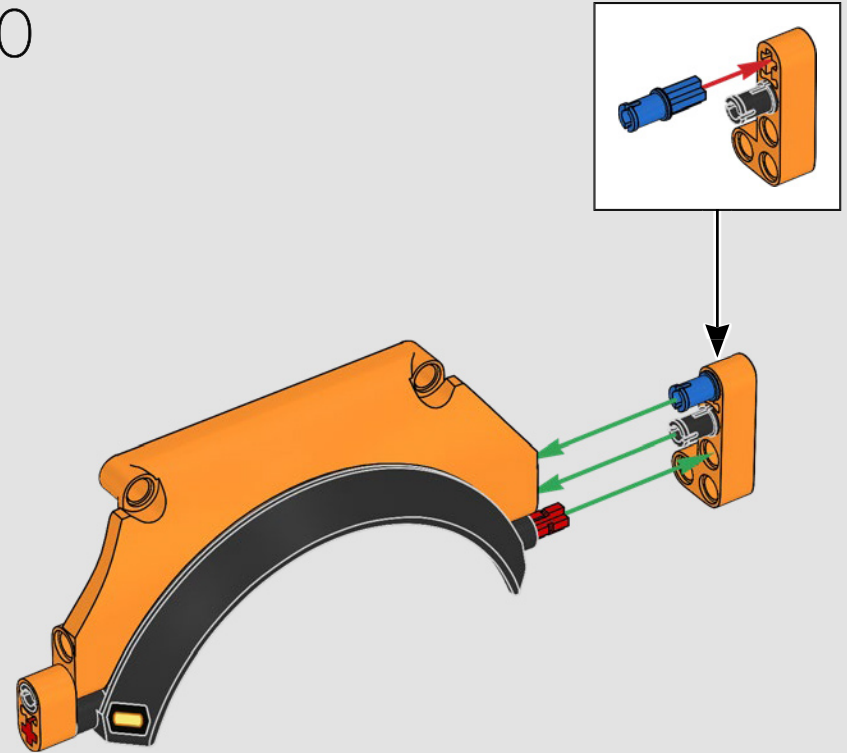

351

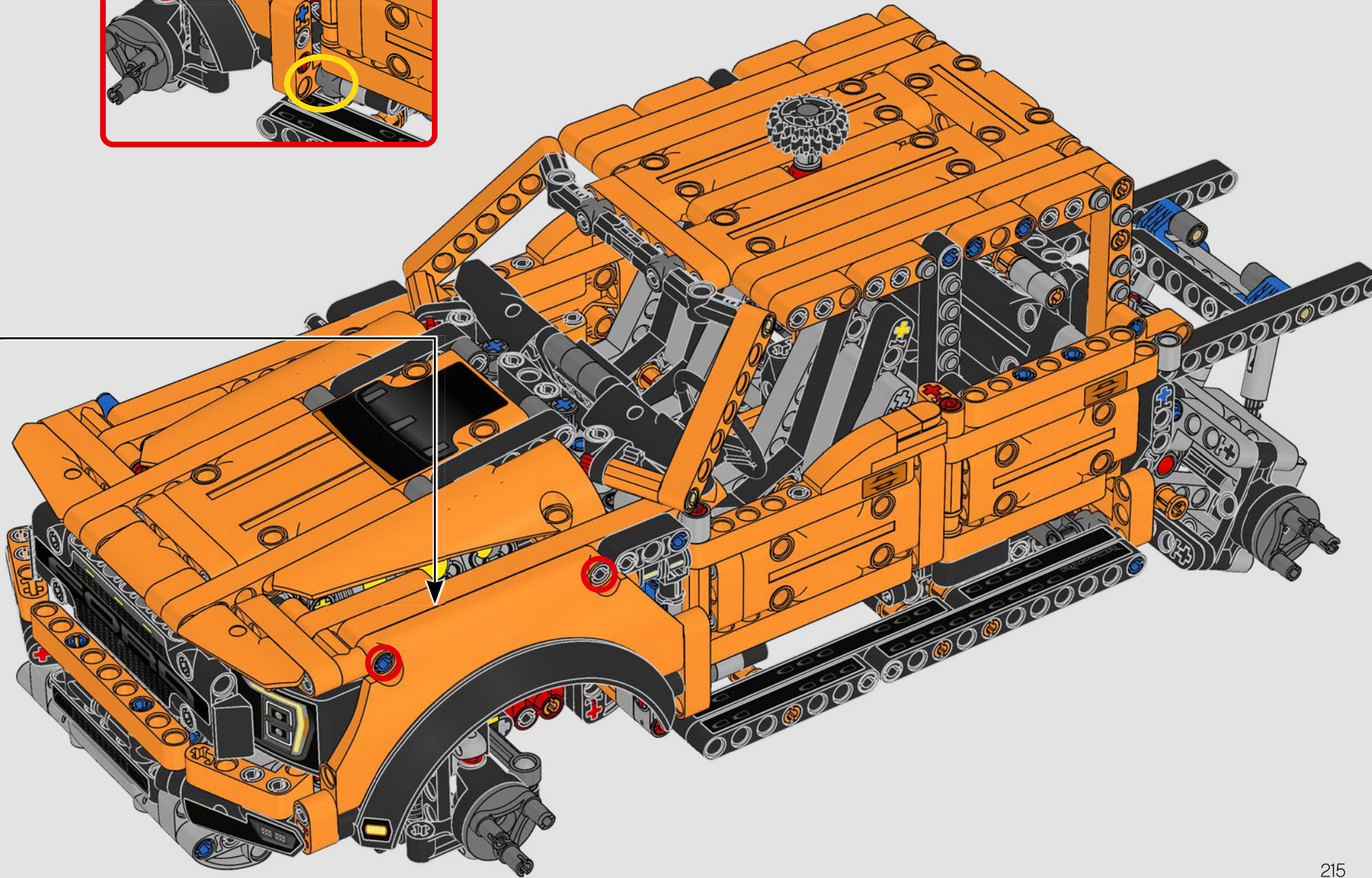
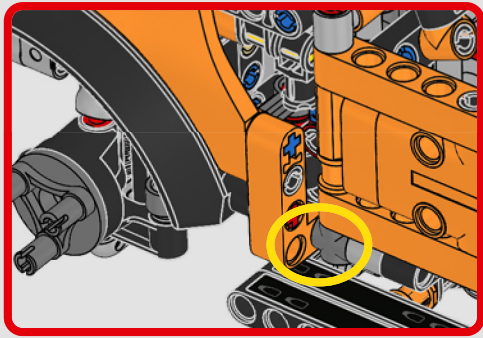

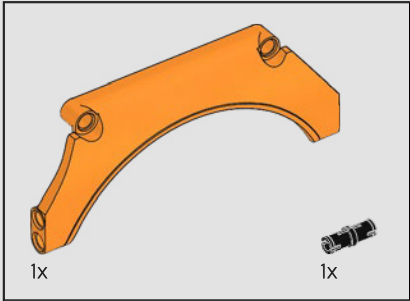
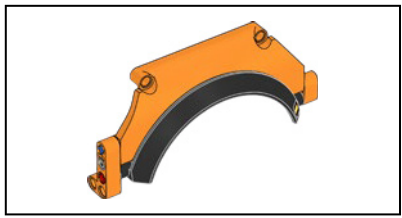

352

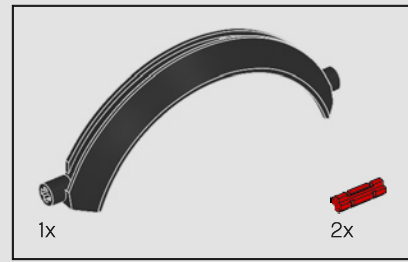
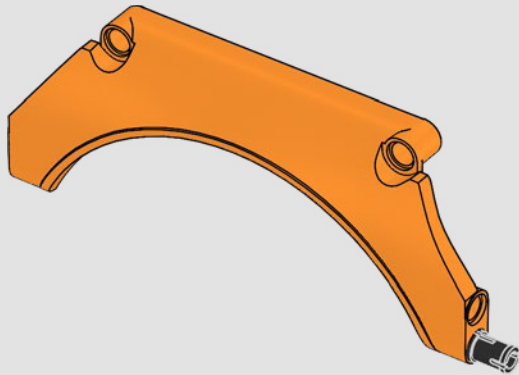

353

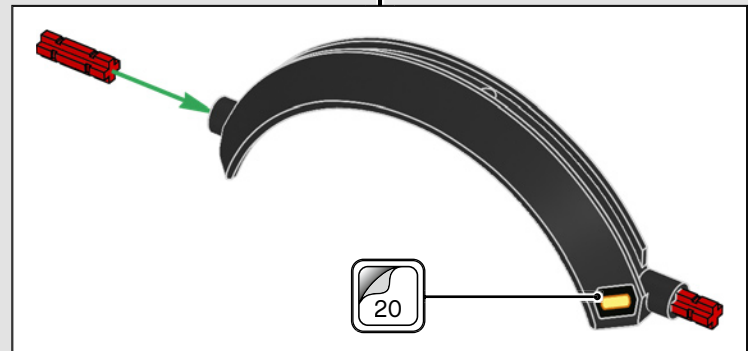
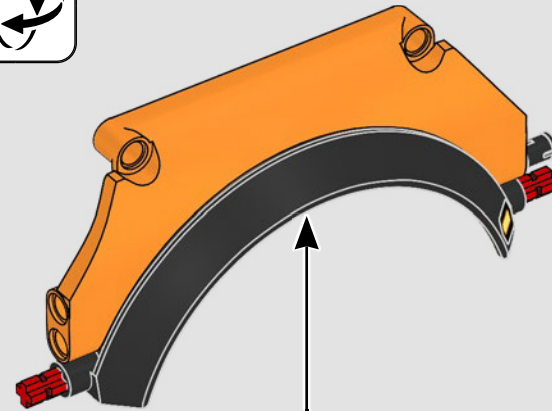
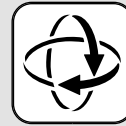



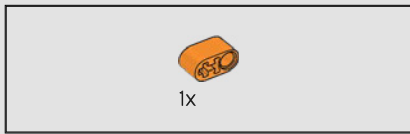

354

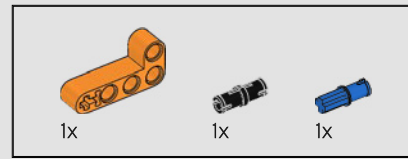
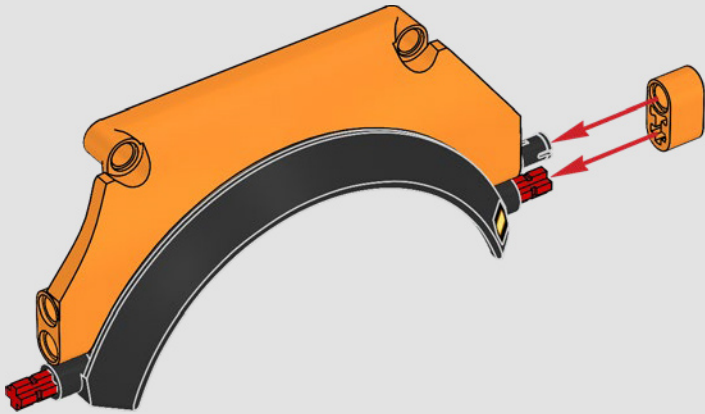

355

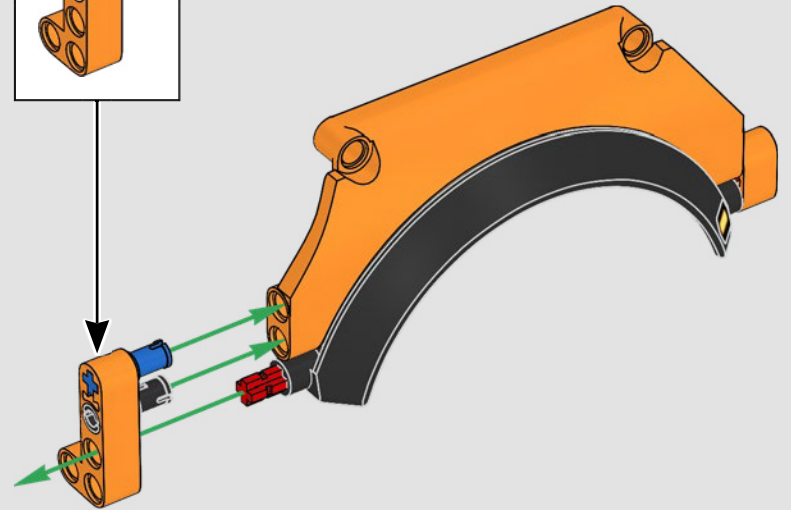
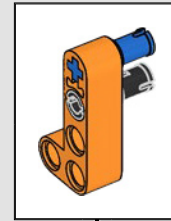

356

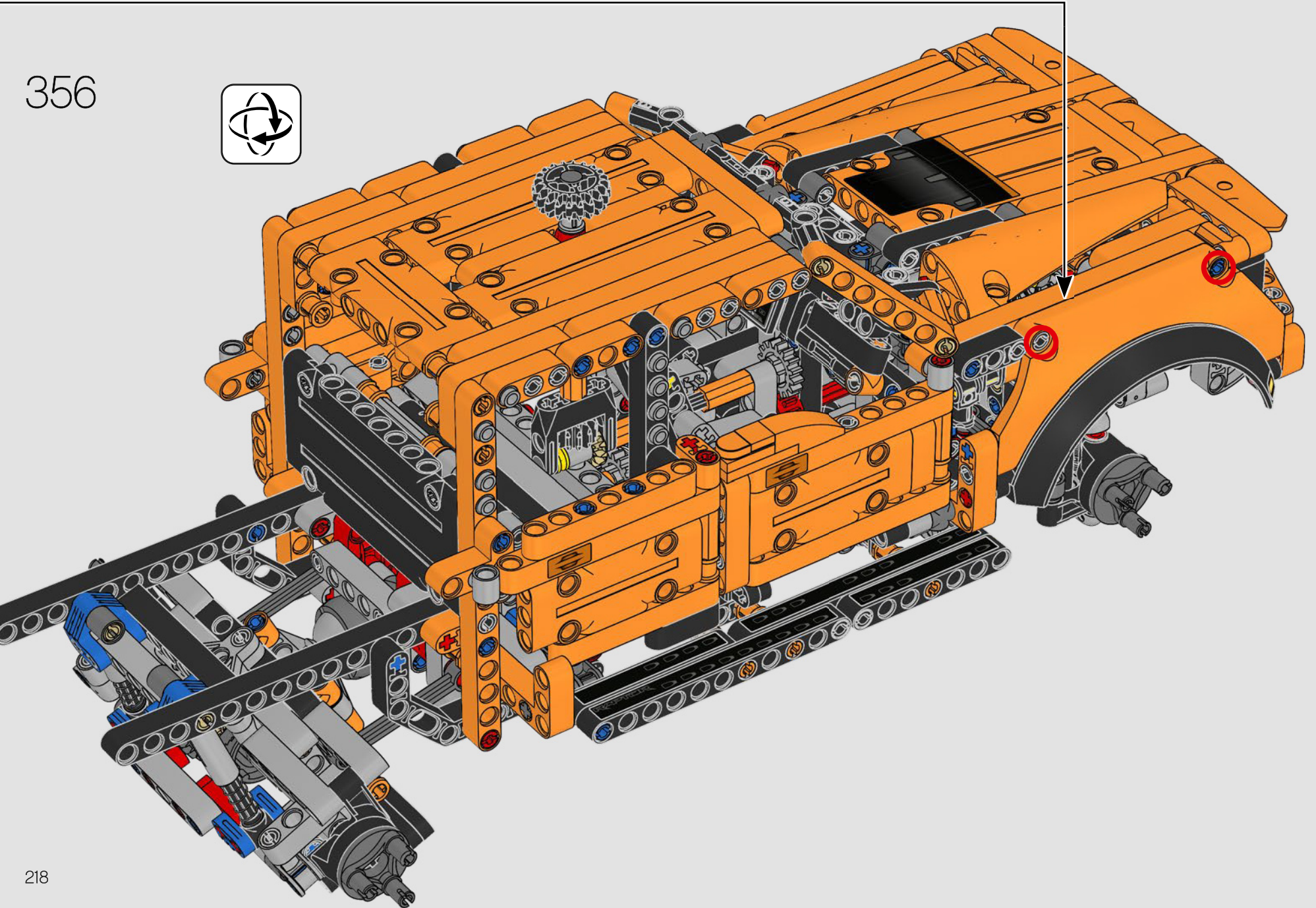



357

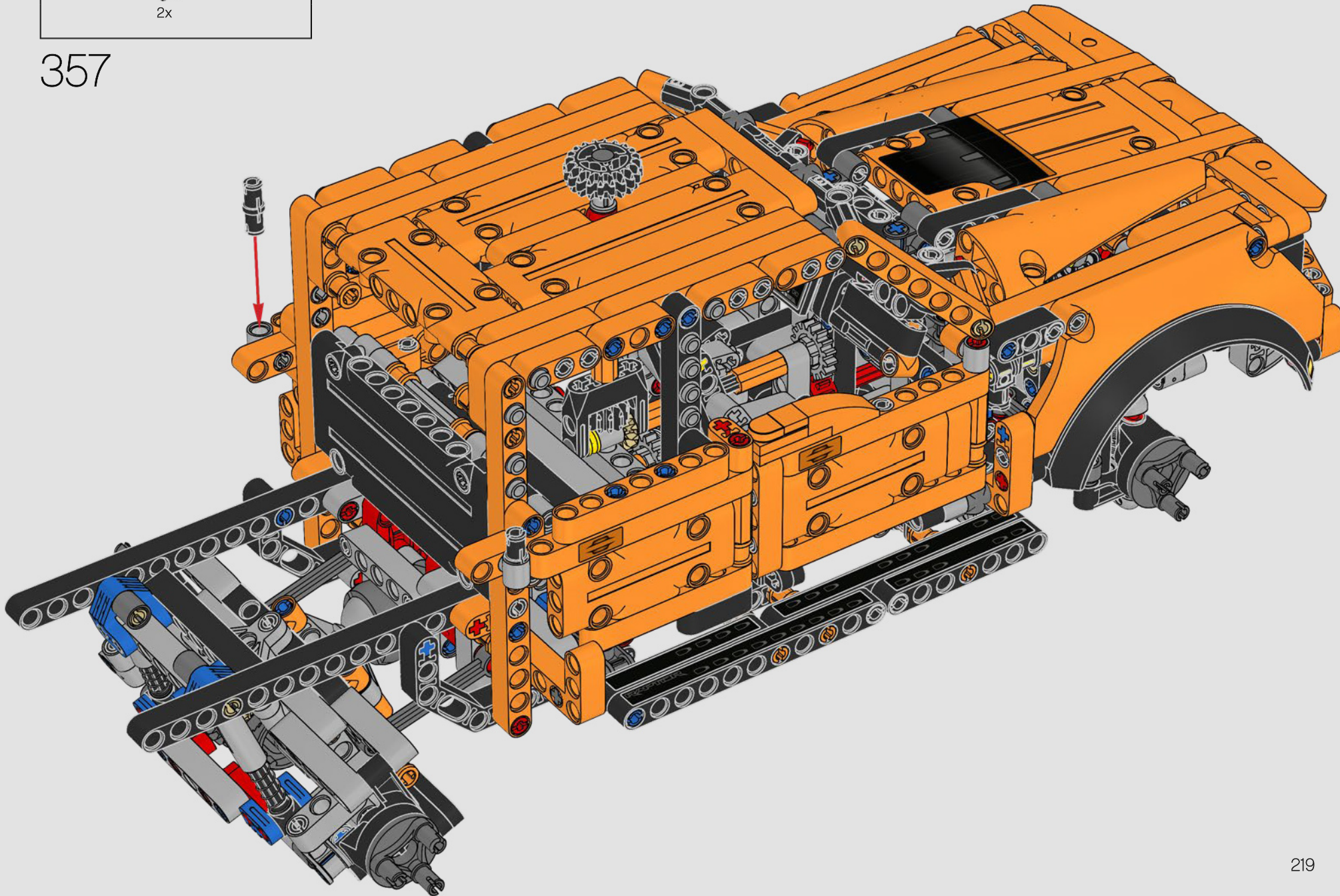

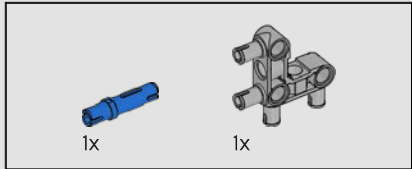
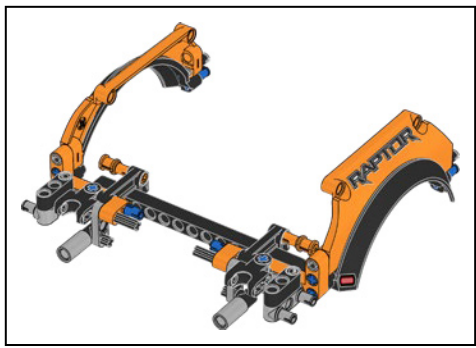

358

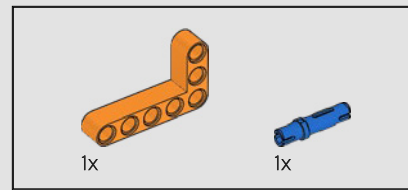
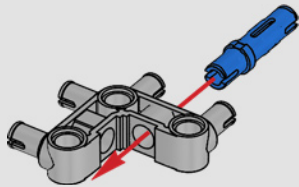

359

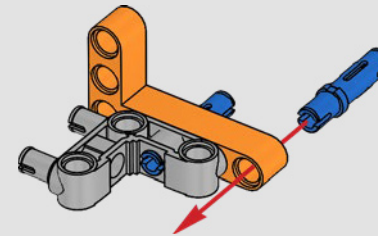

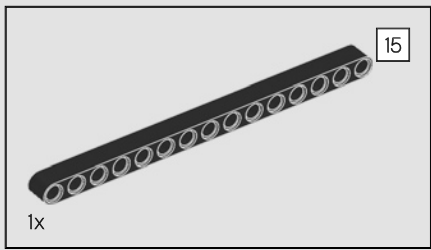

360

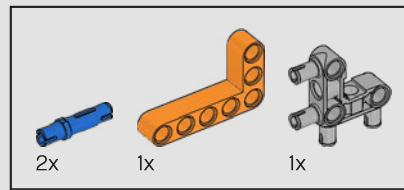
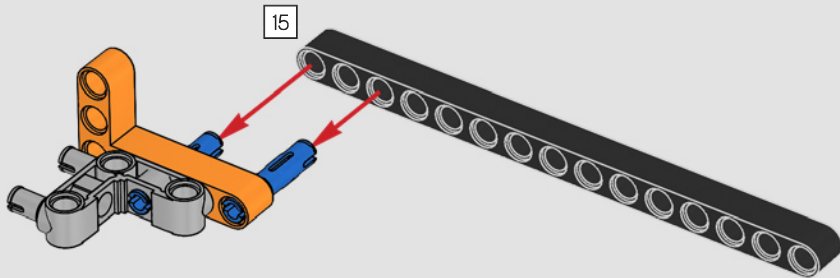

361

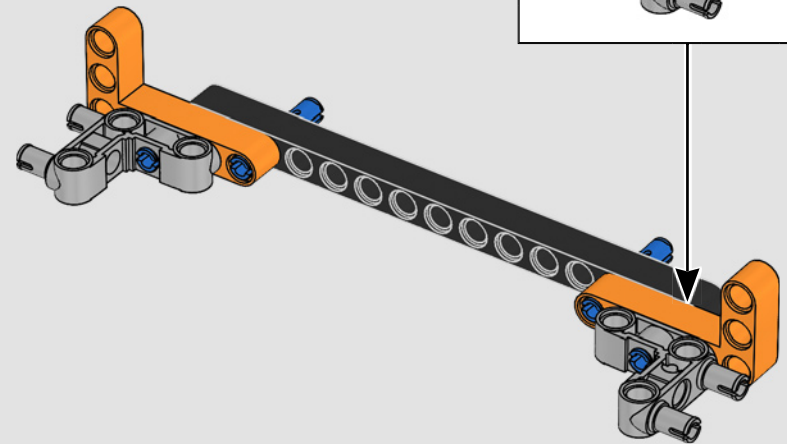
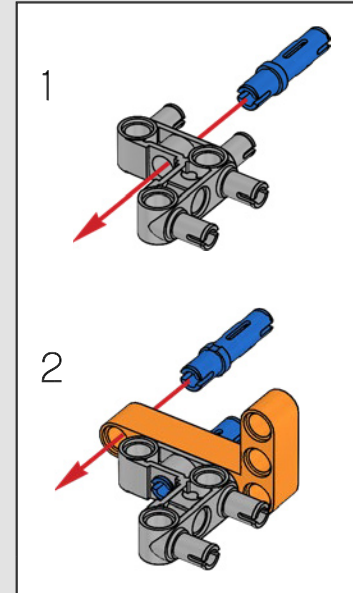

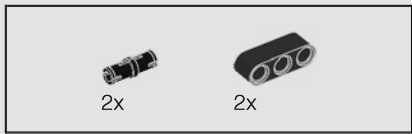

362

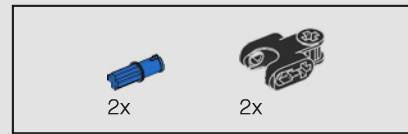
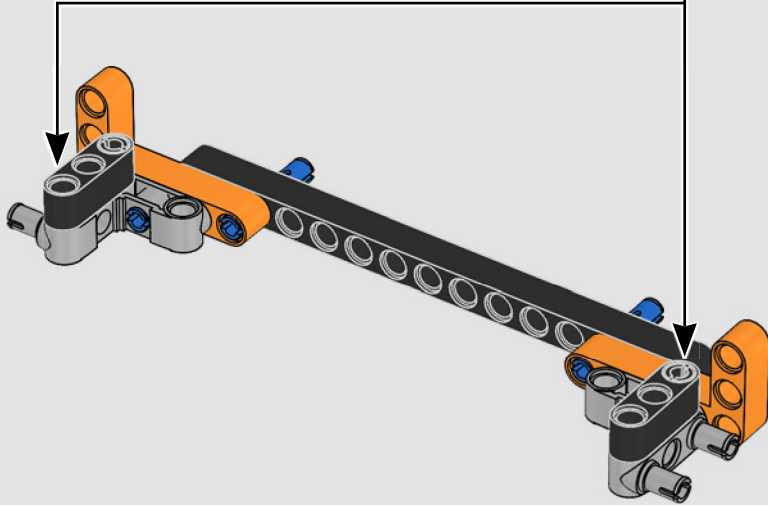
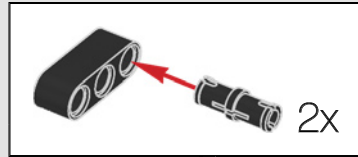

363

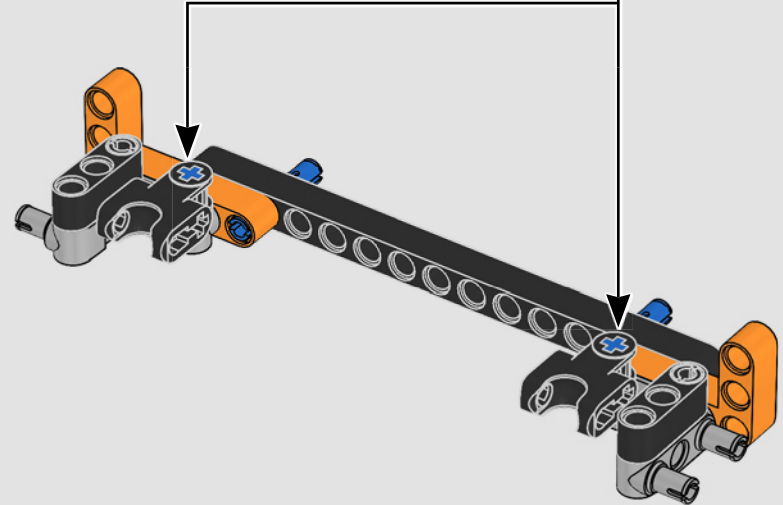
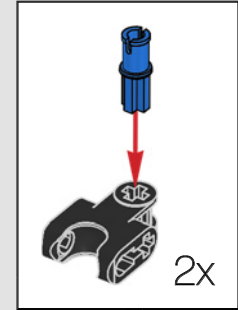

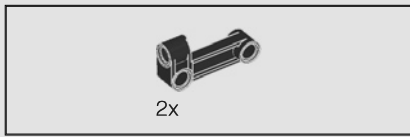

364

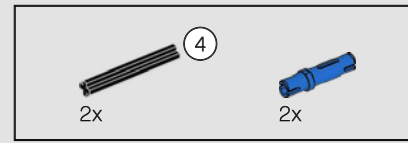
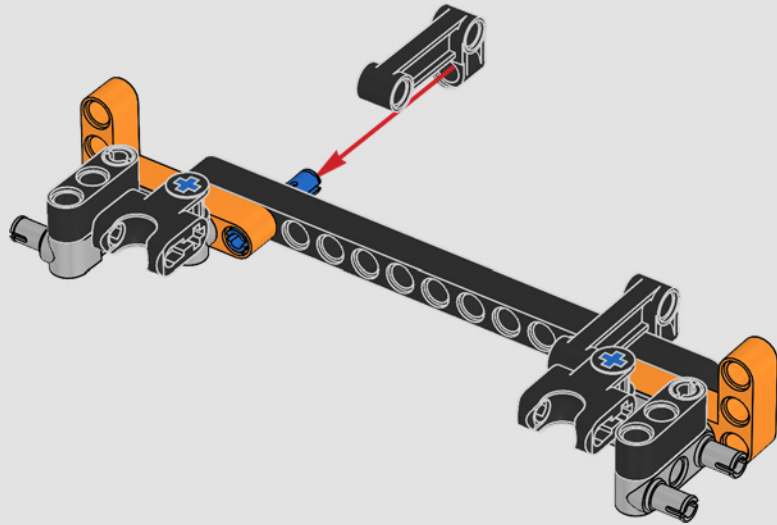

365

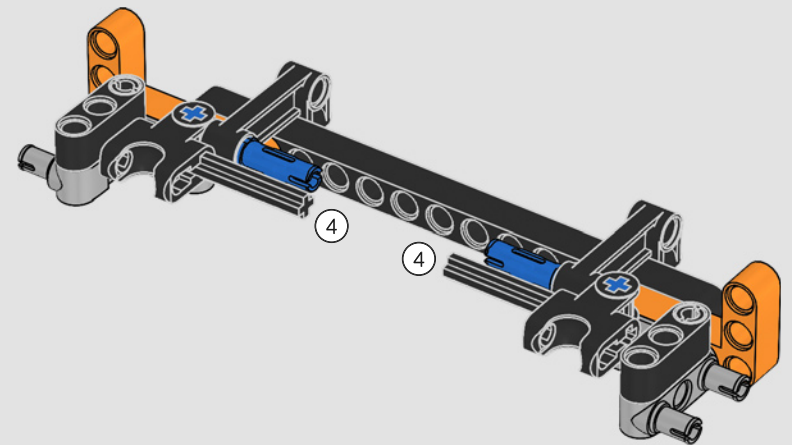
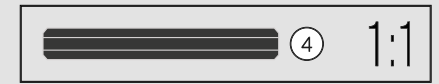

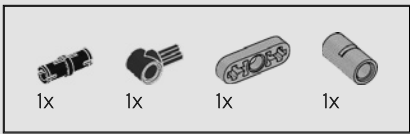

366

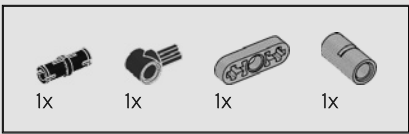
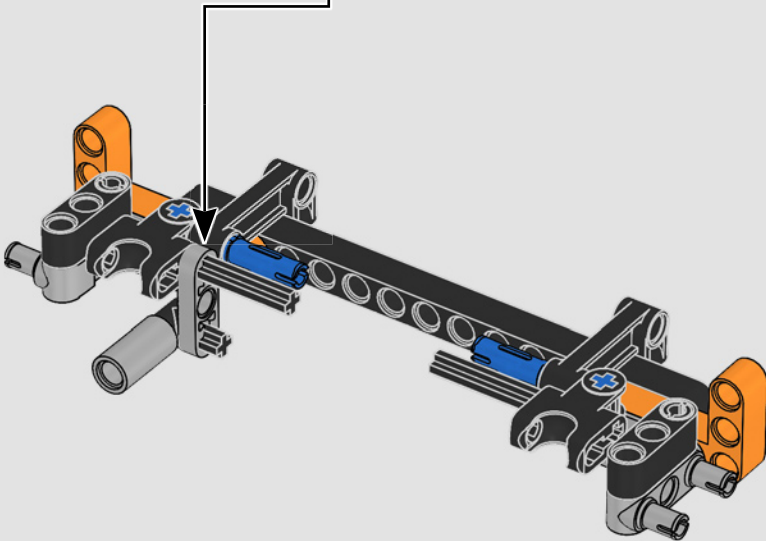
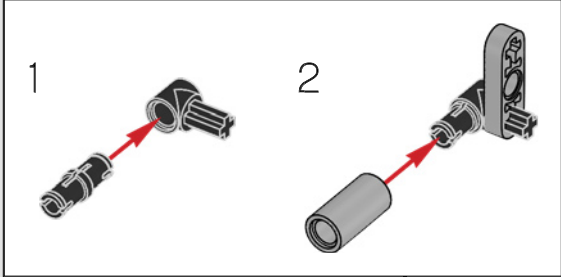

367

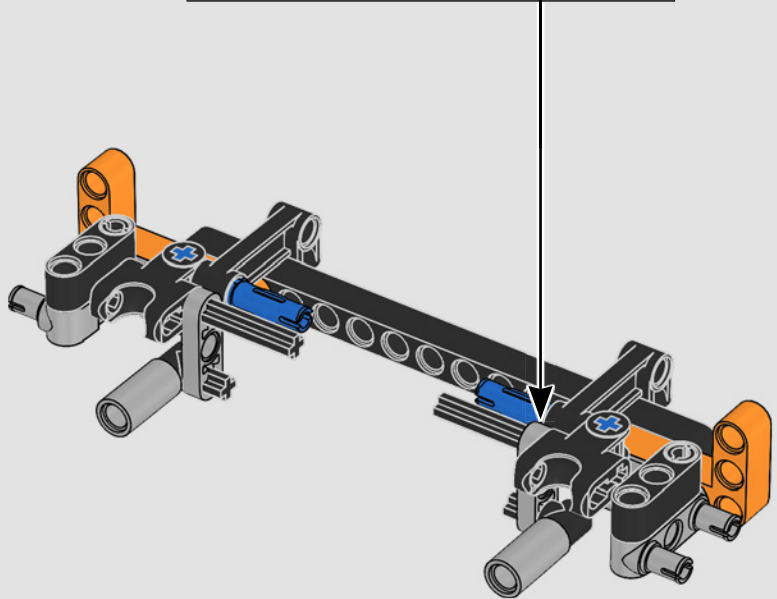
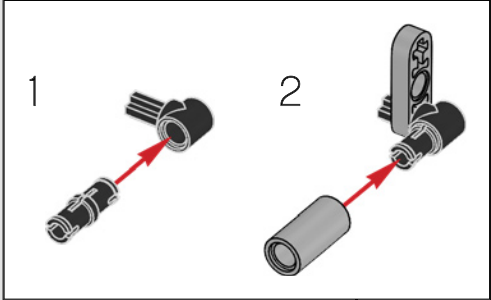





368

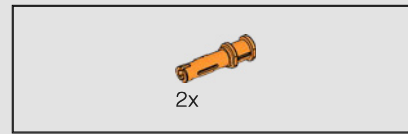

369

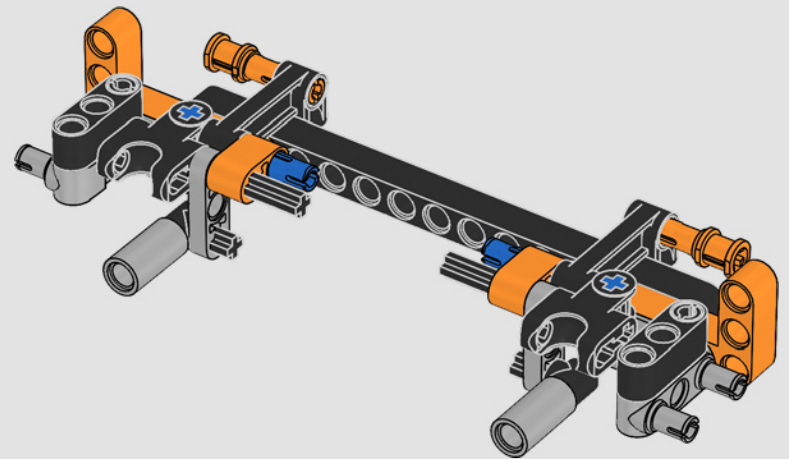
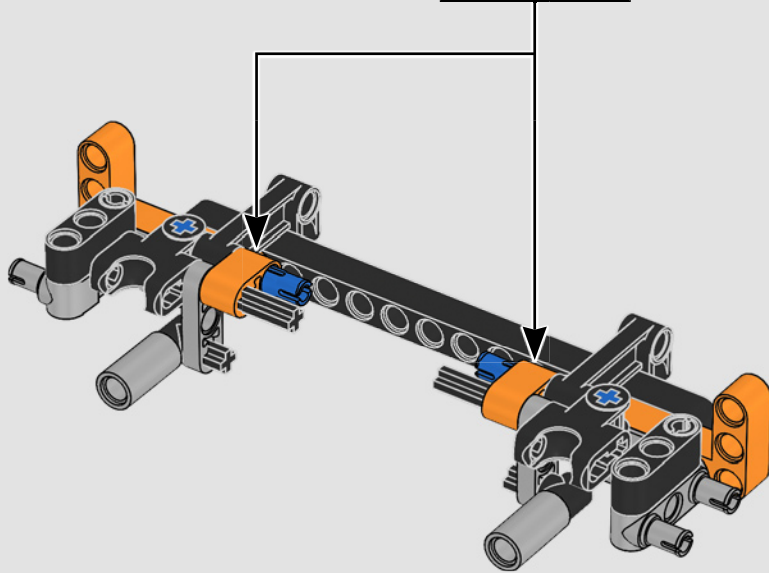

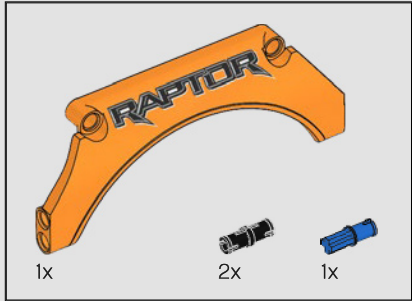

370

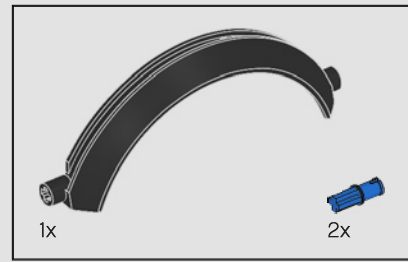

371

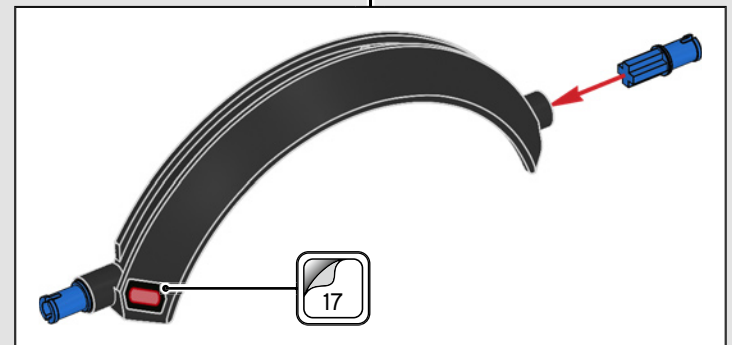
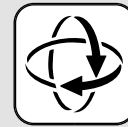

*Le premier Raptor produit affichait une teinte orange fondu avec un décor numérique évoquant des traces de boue.*

372

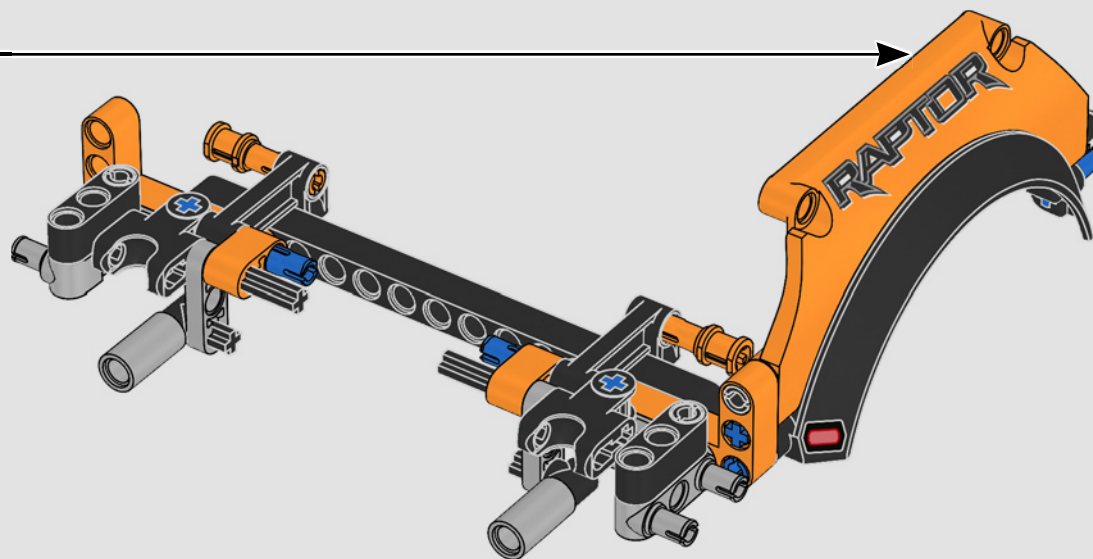

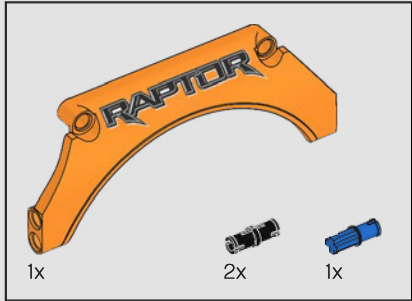

373

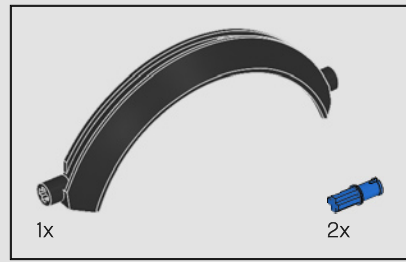
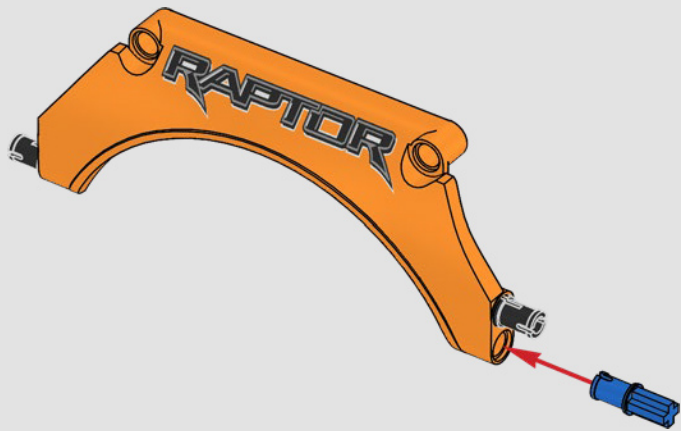

374

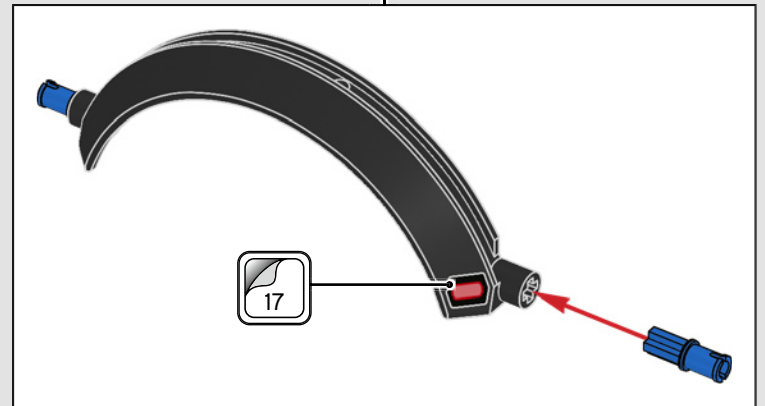

375

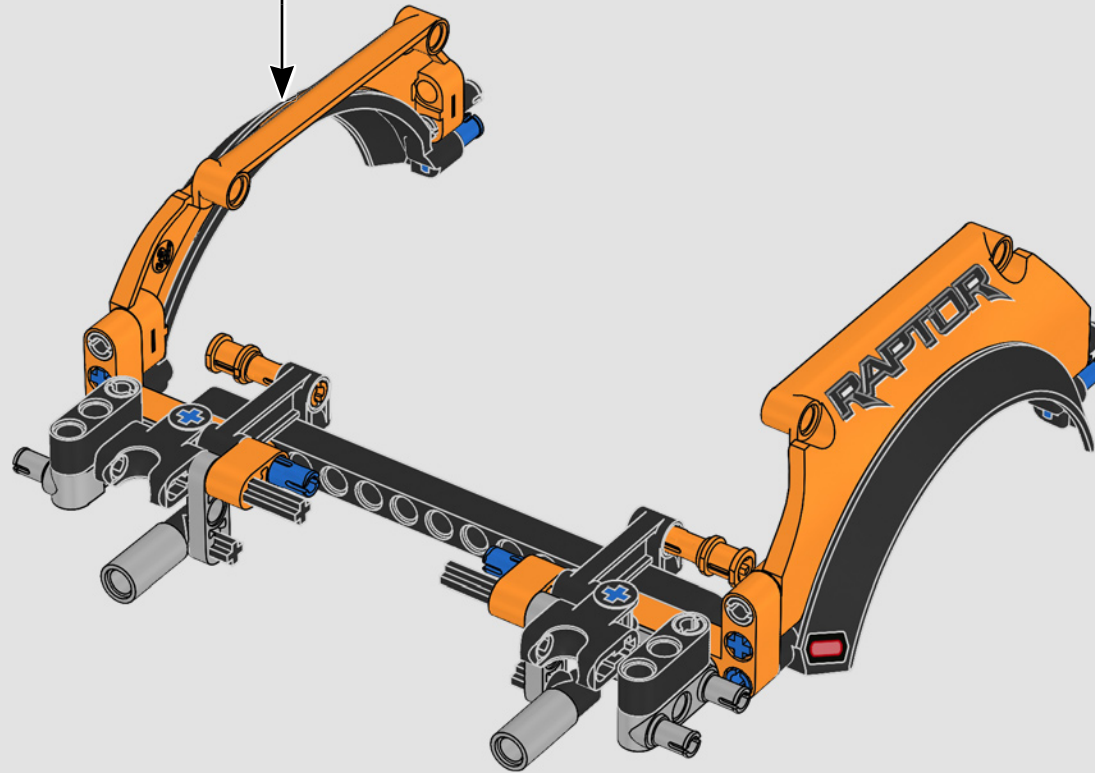

376

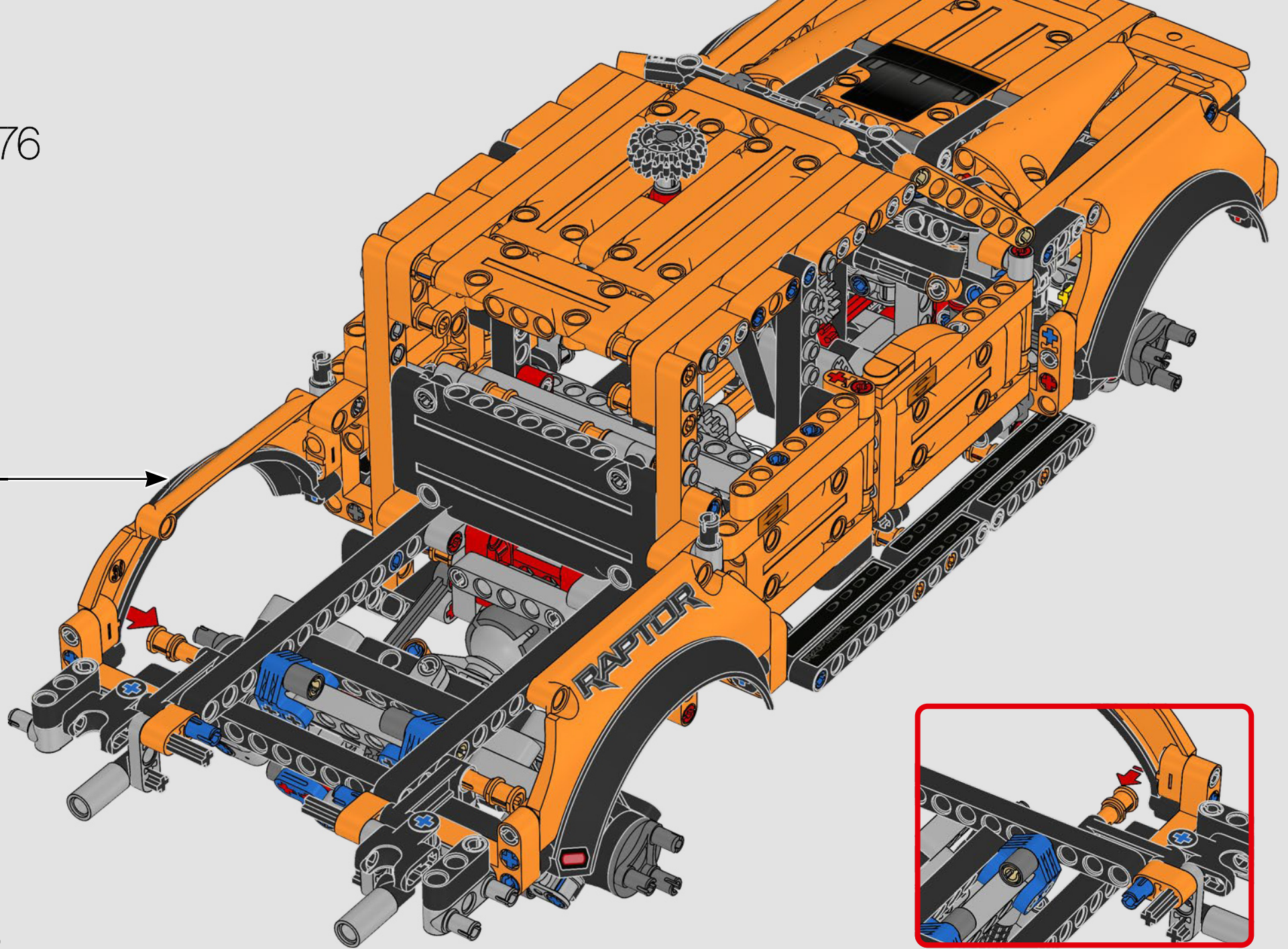

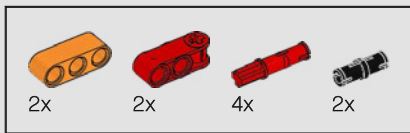

377

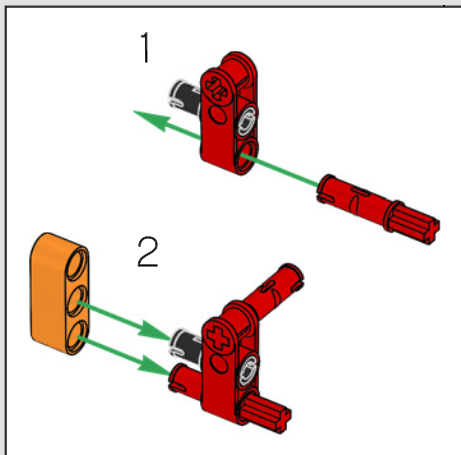
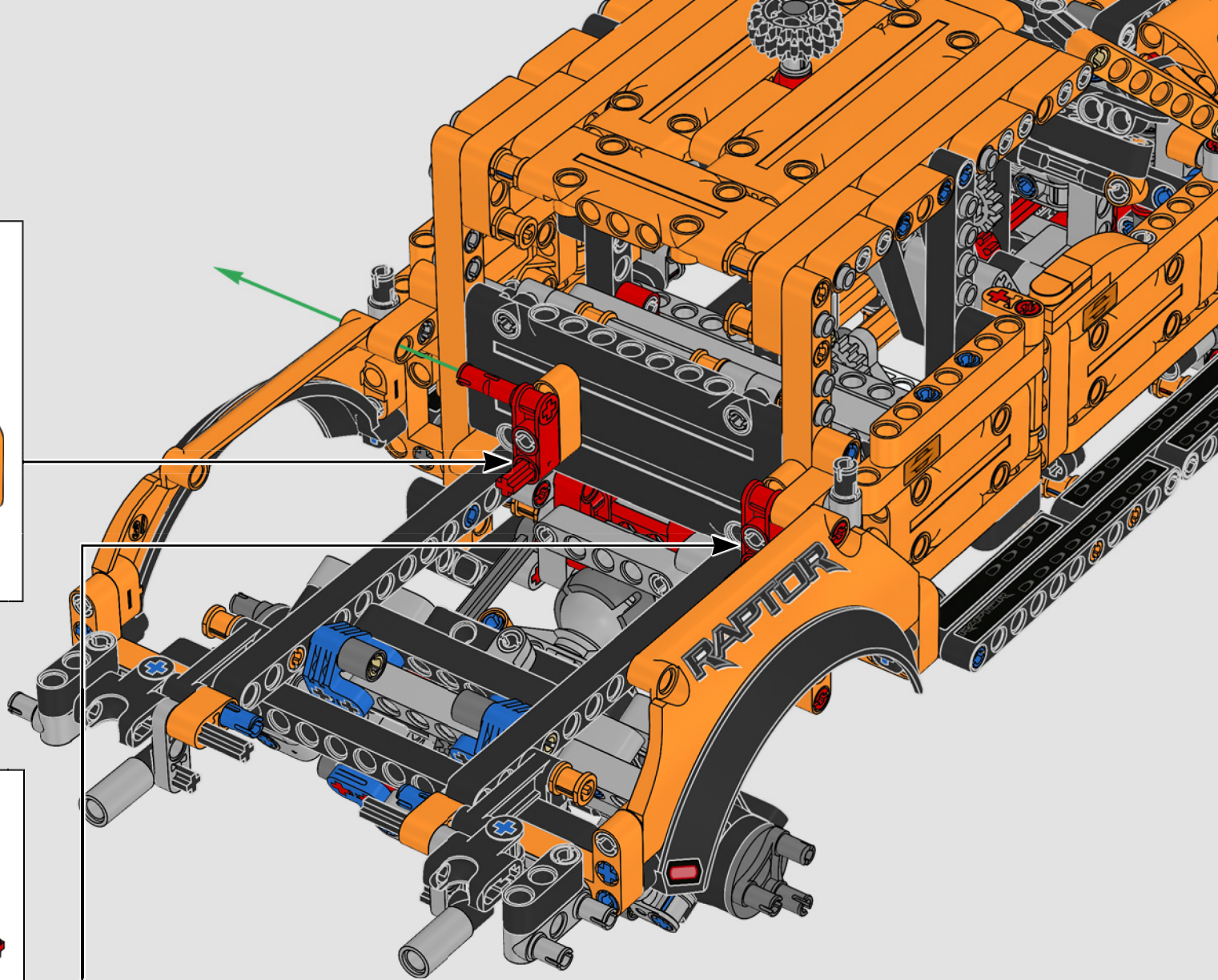
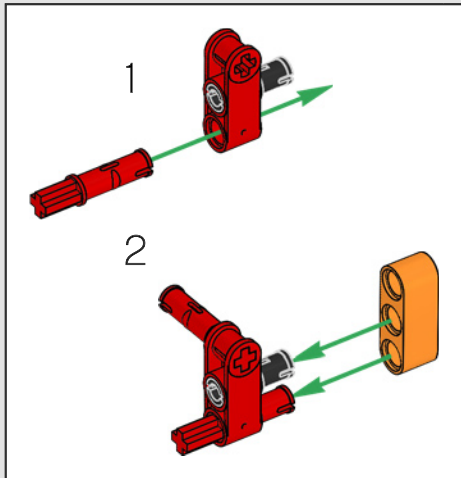

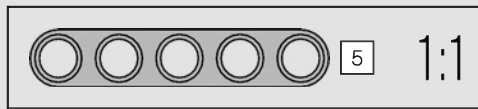
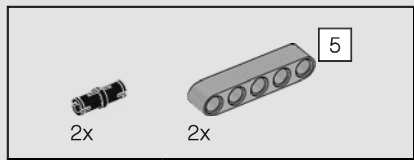

378

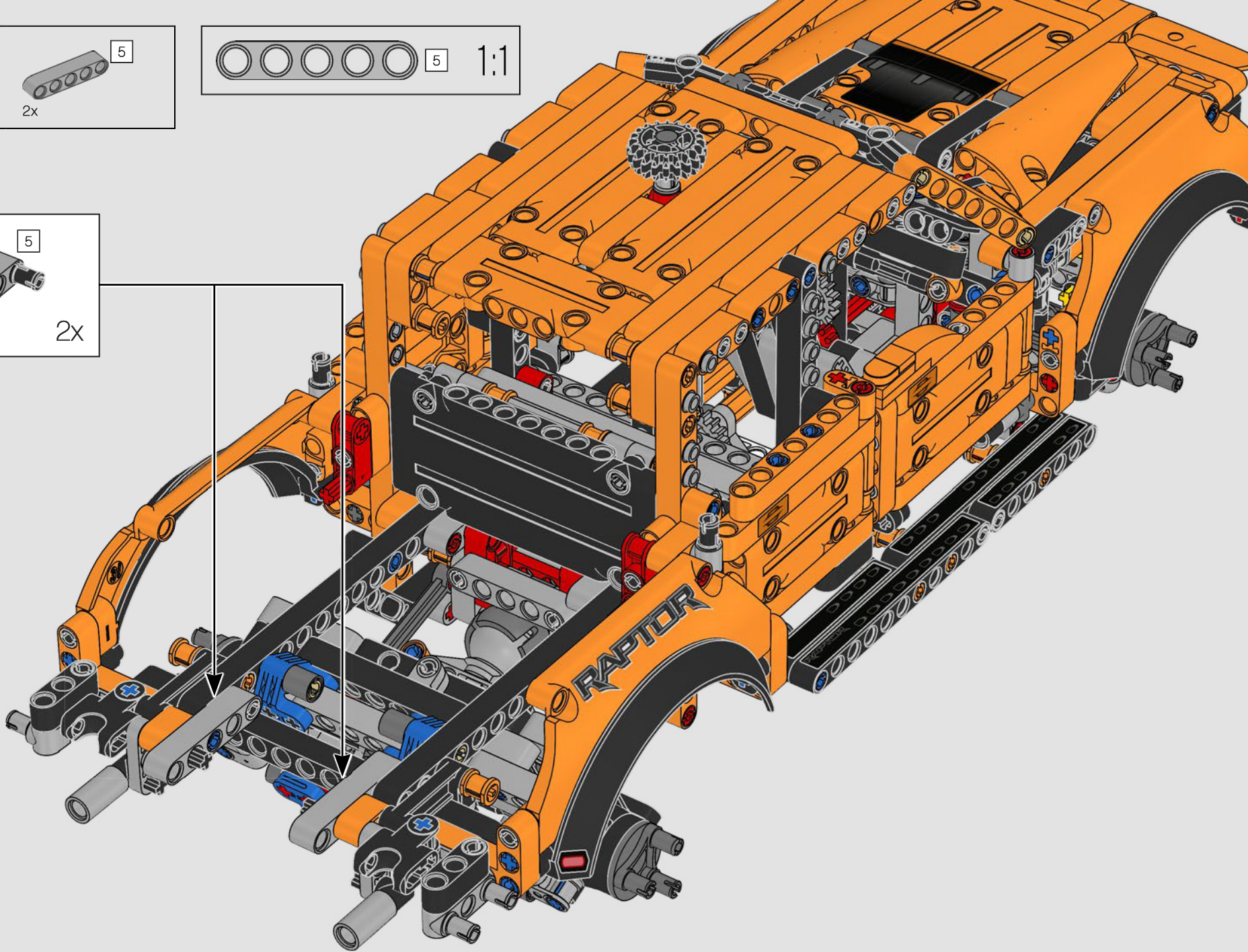
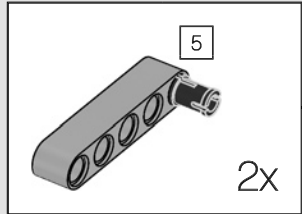



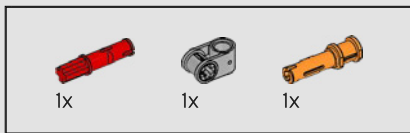

379

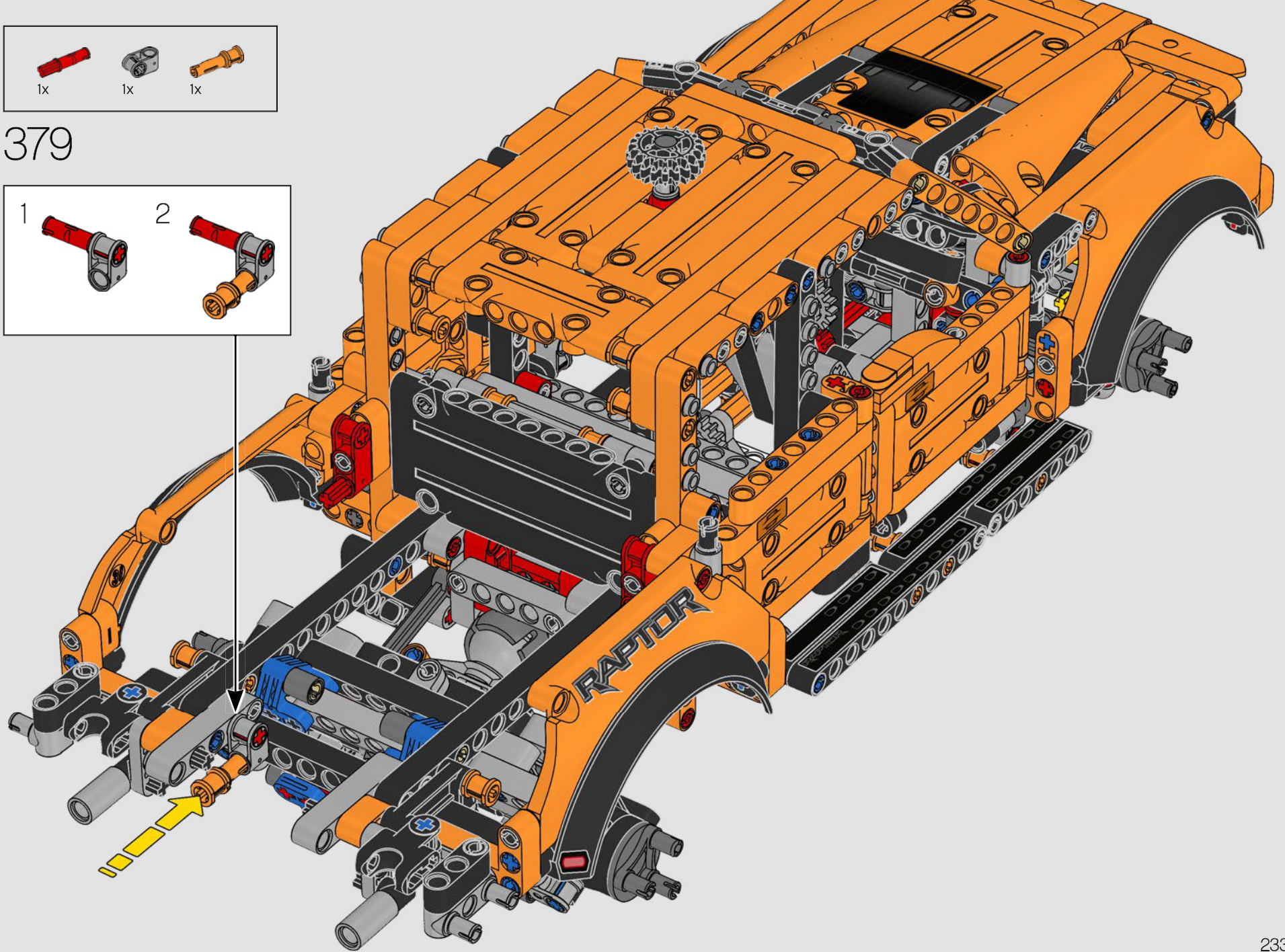
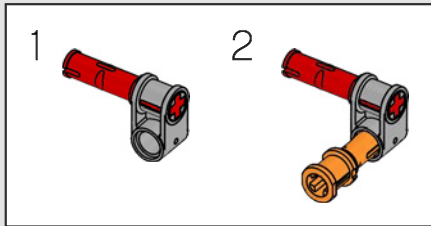

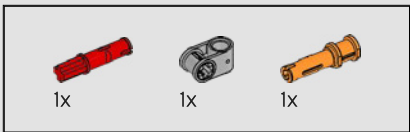

380

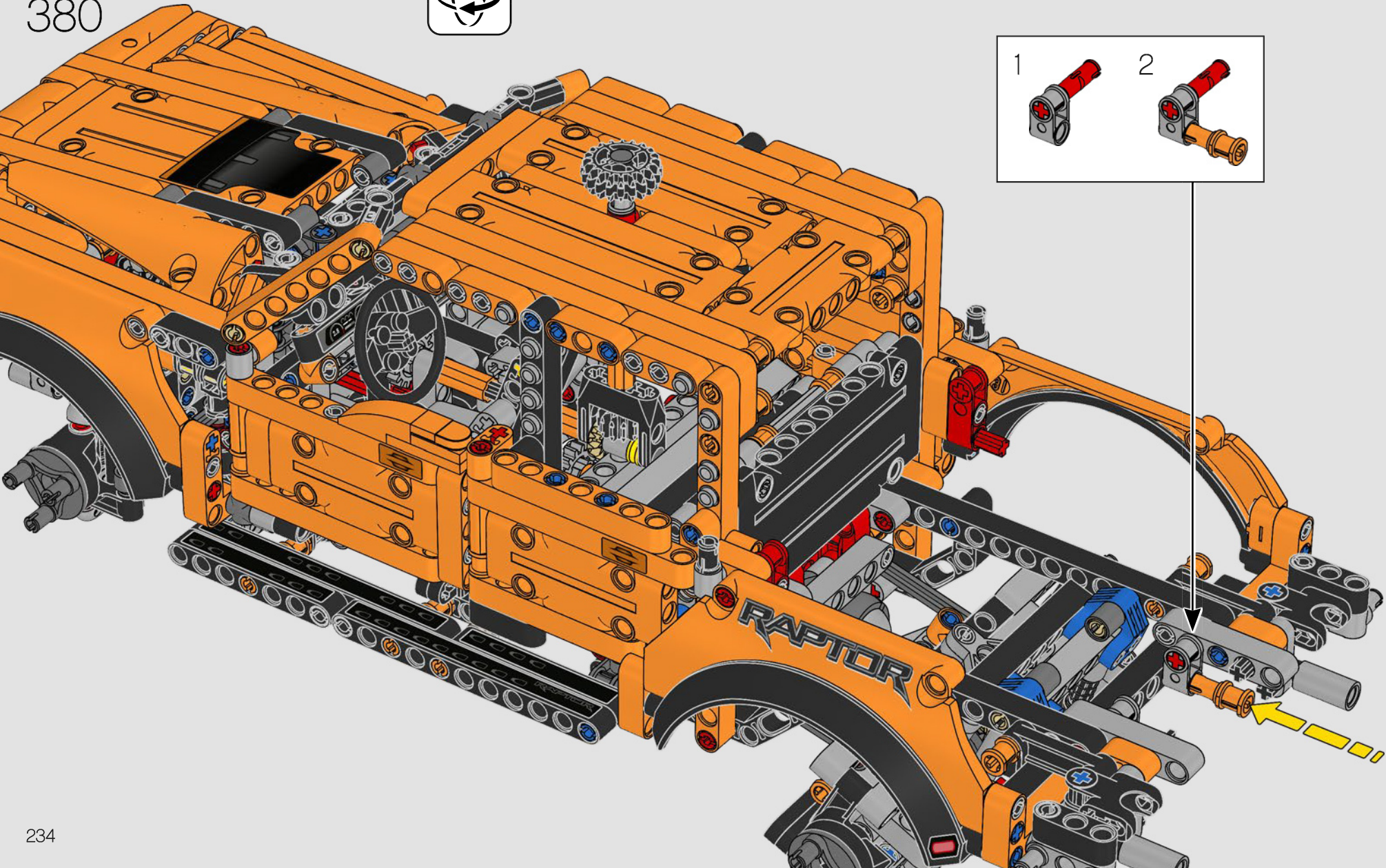
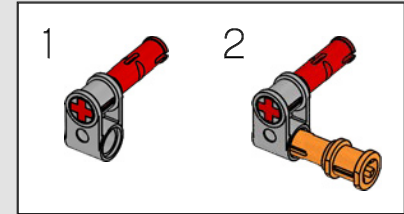

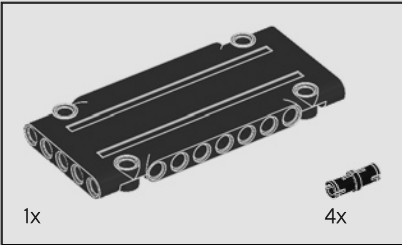
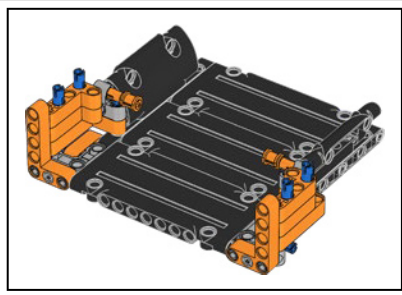

381

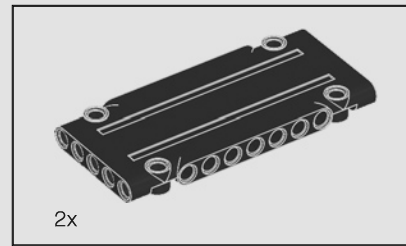
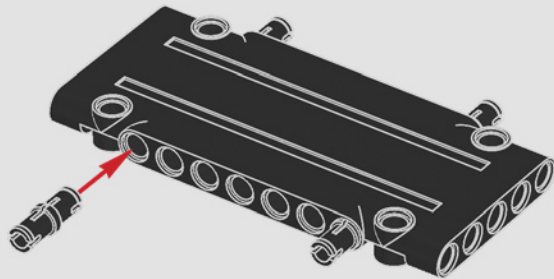

2x

382

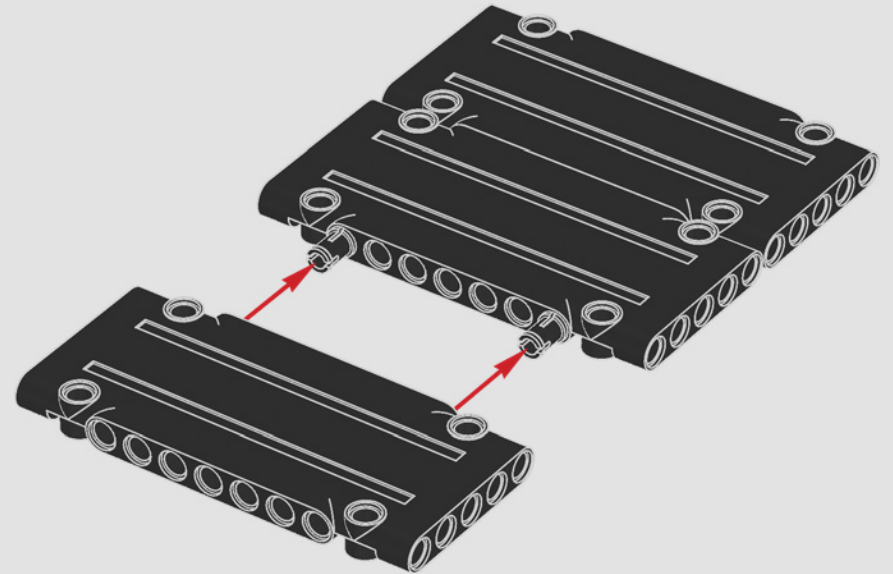



383

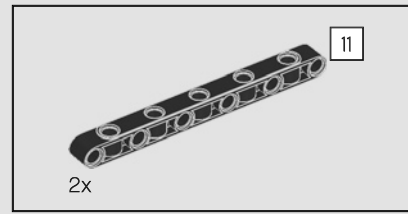
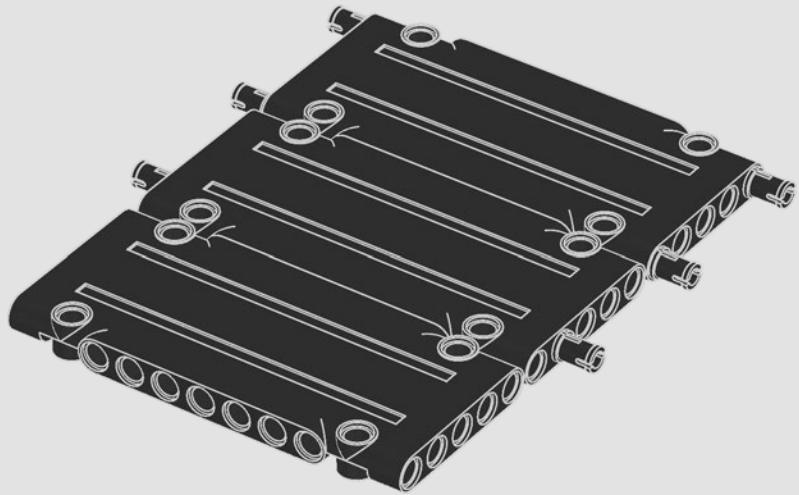

2x

384

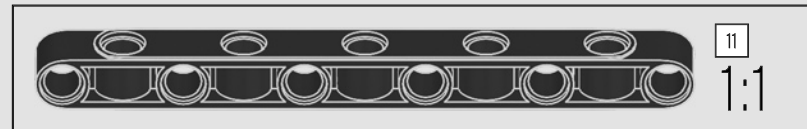
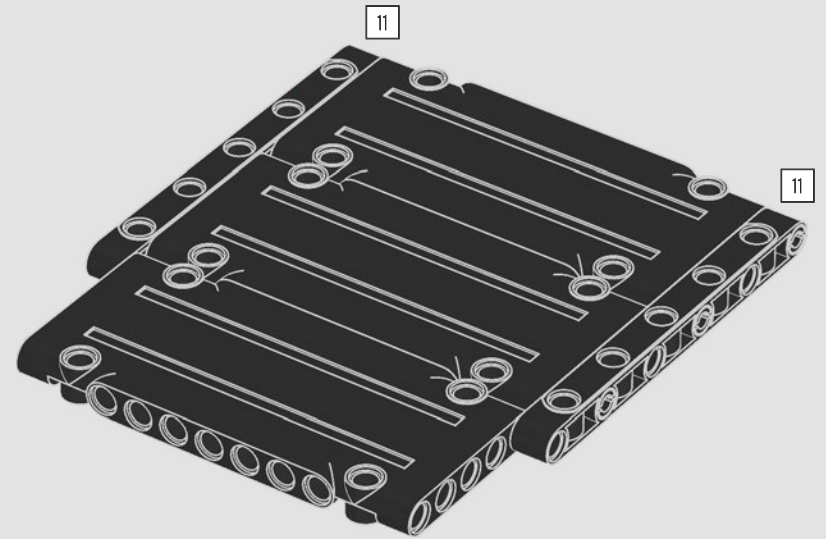

1:1

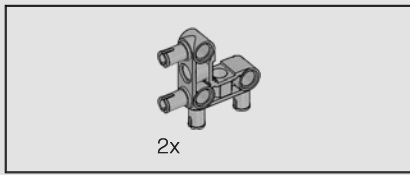

385

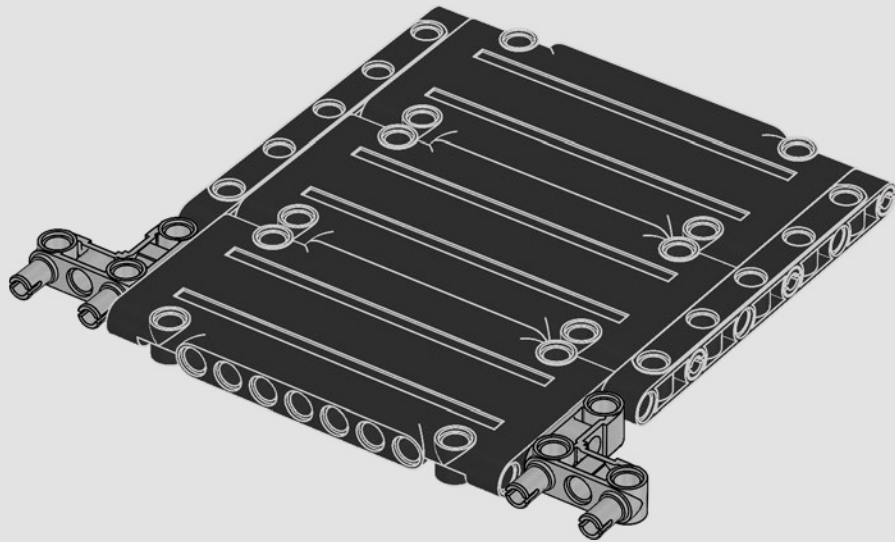

386

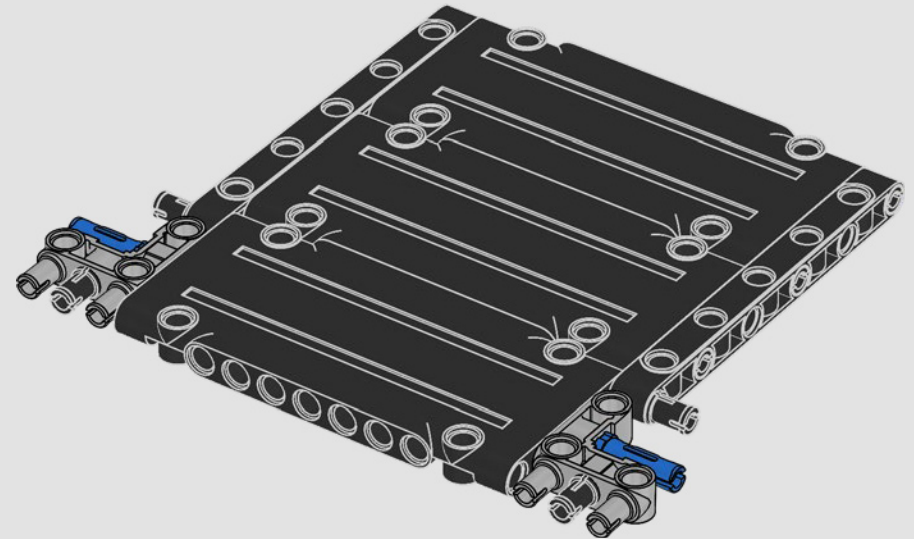

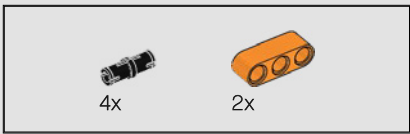

387

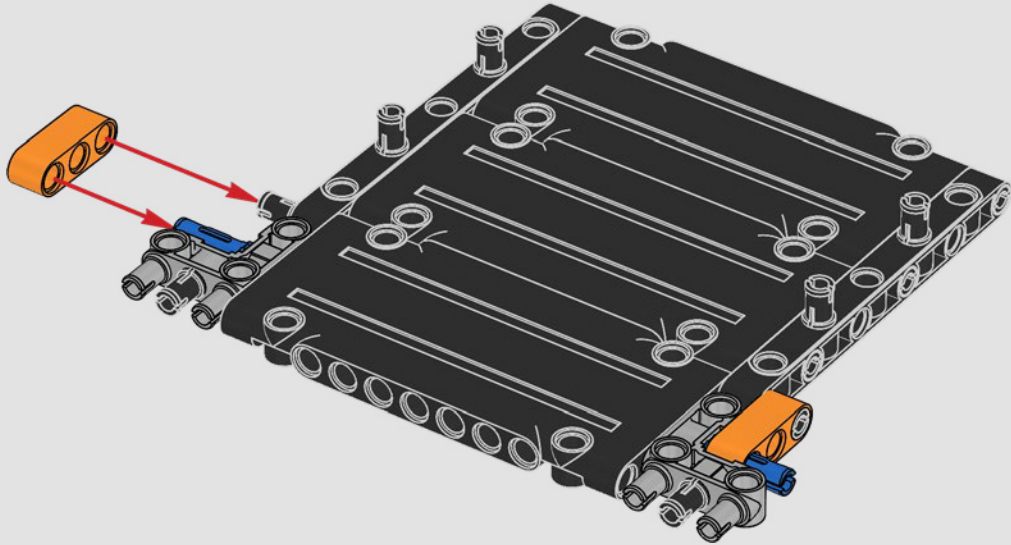

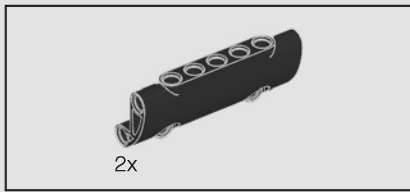

388

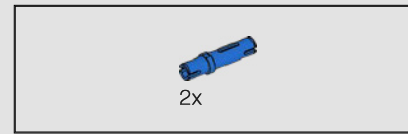
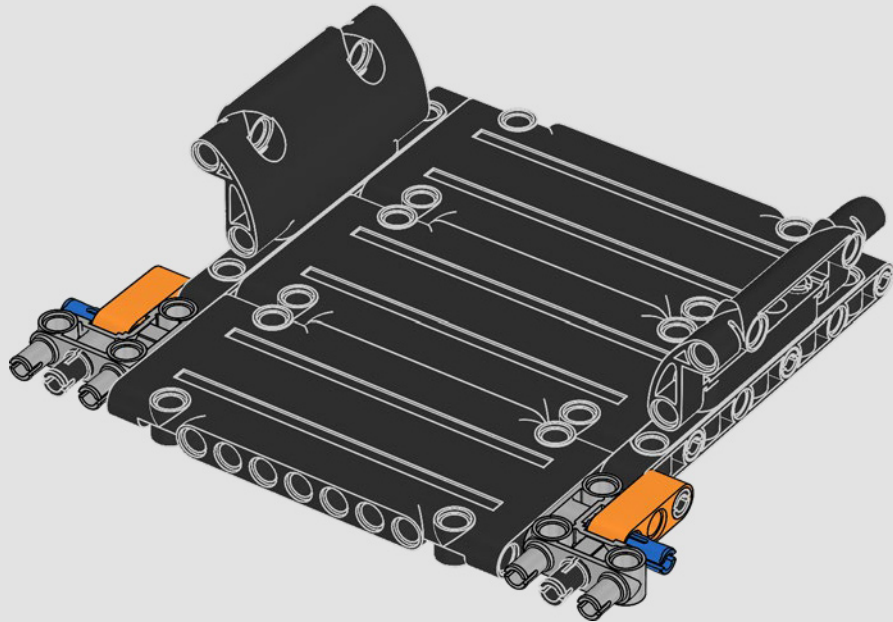

389

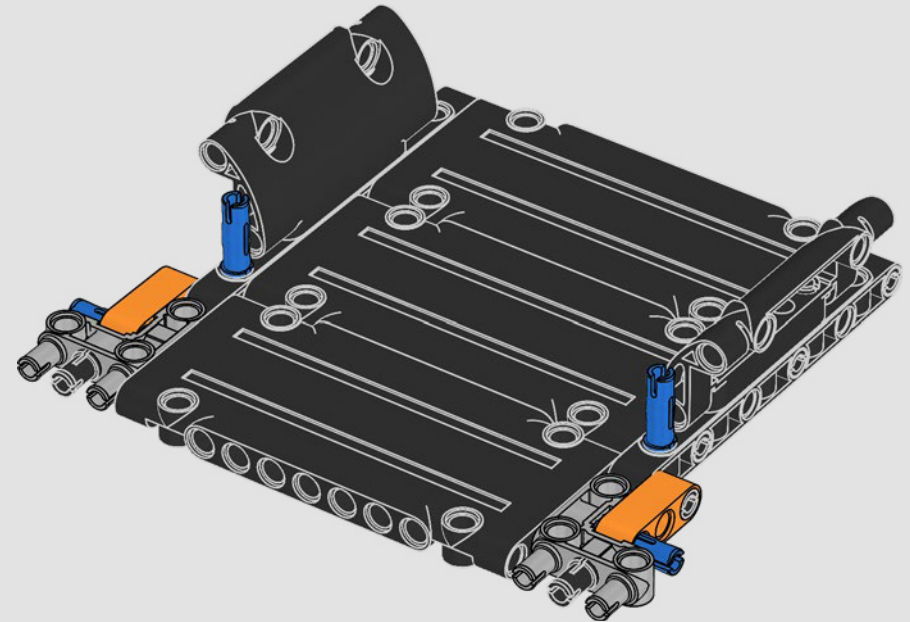

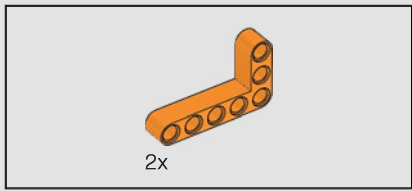

390

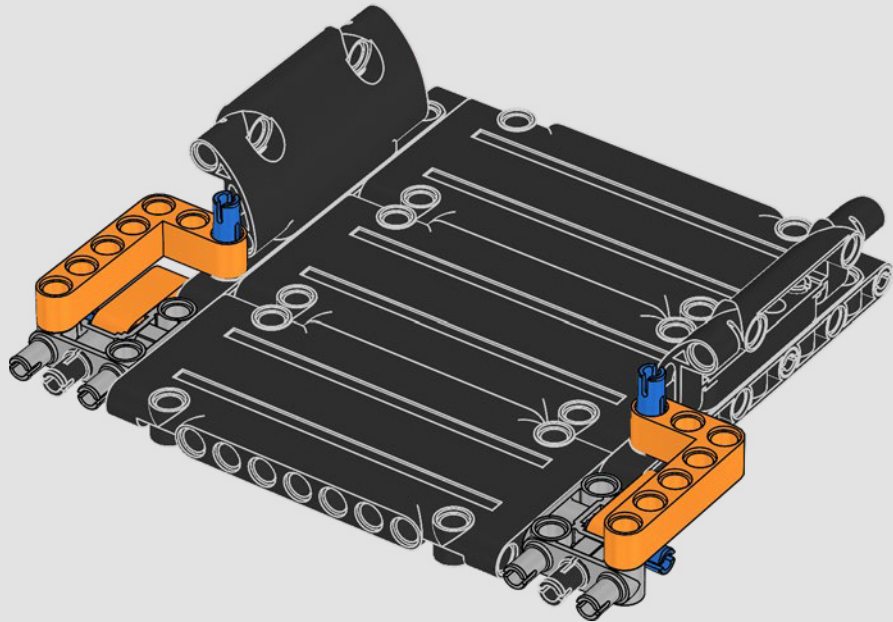

391

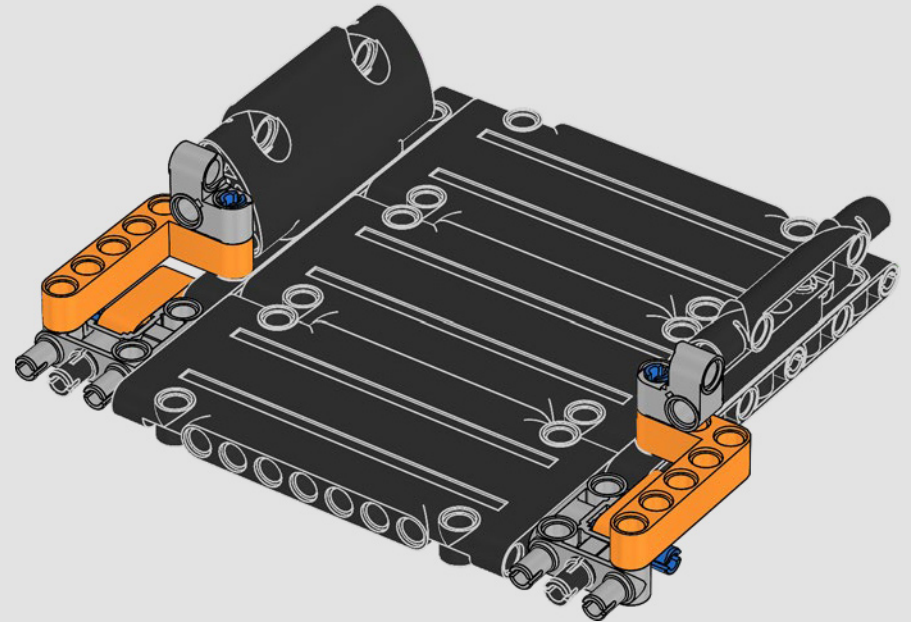



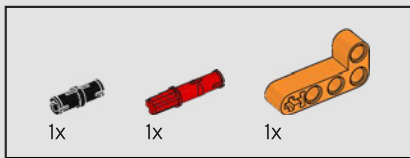

392

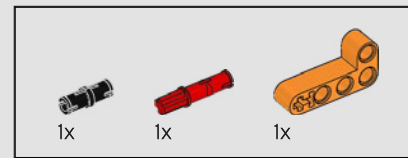
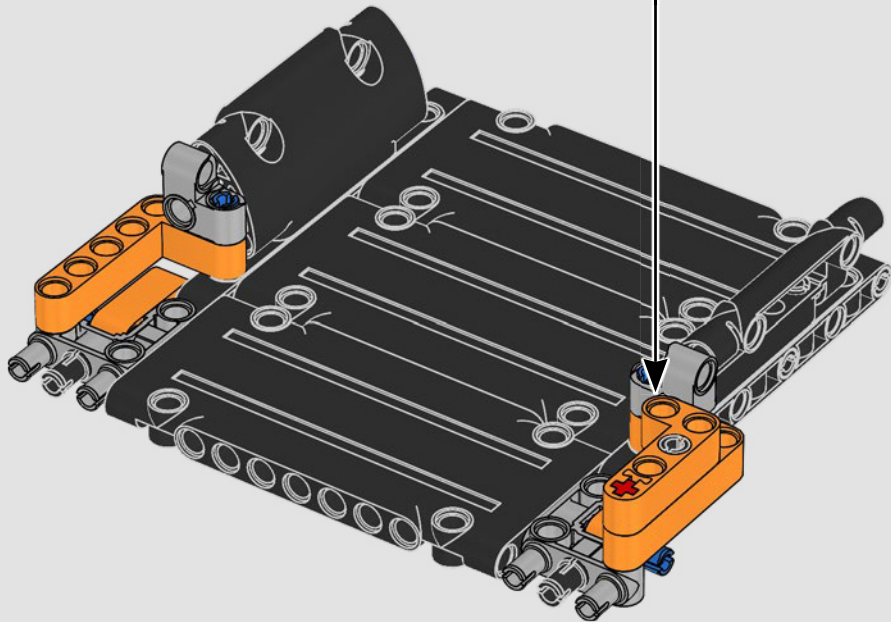
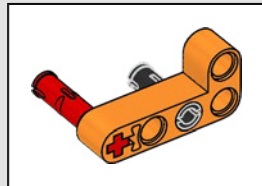

393

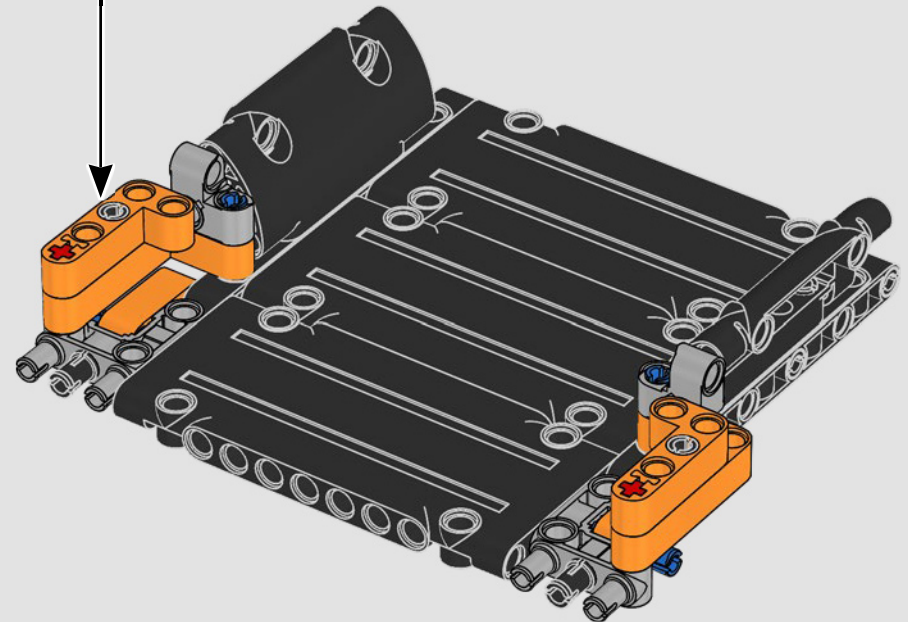
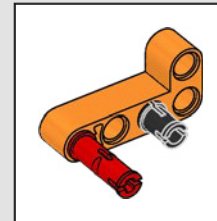

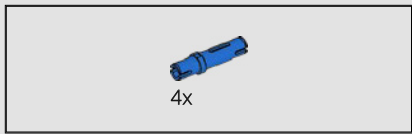

394

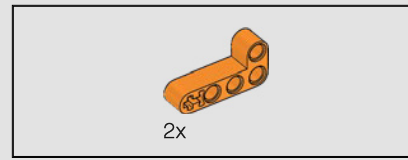
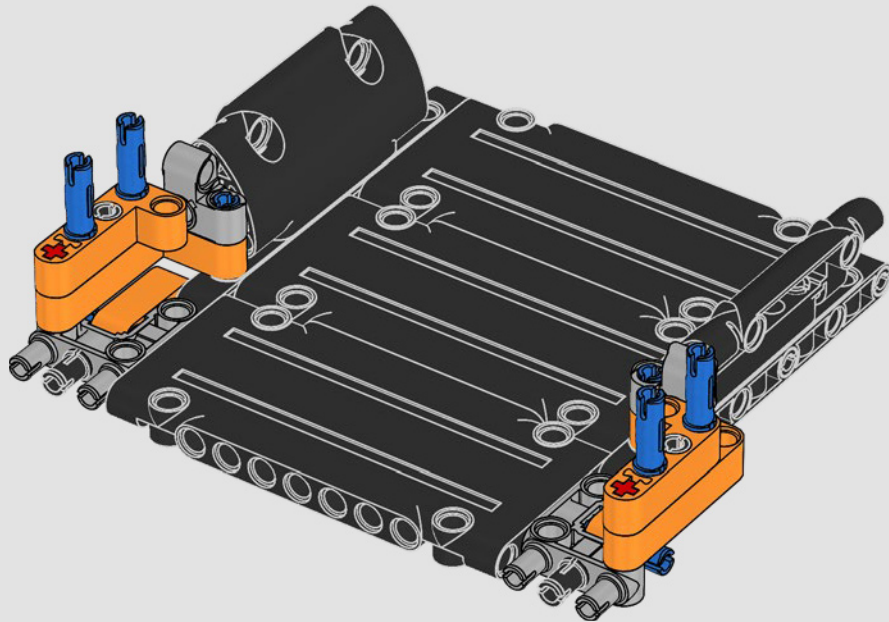

395

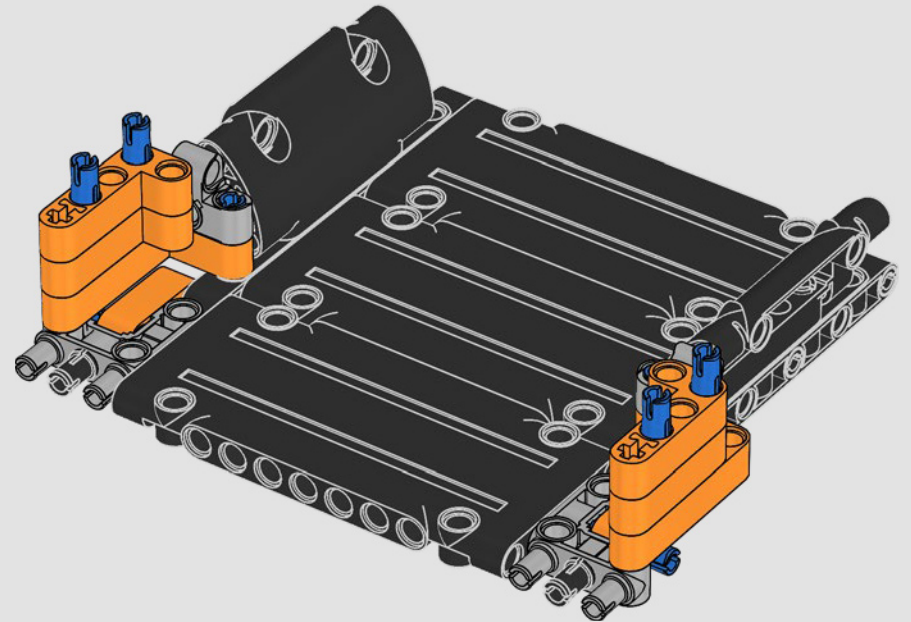

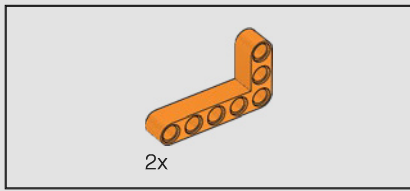

396

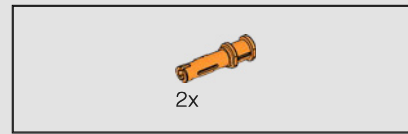
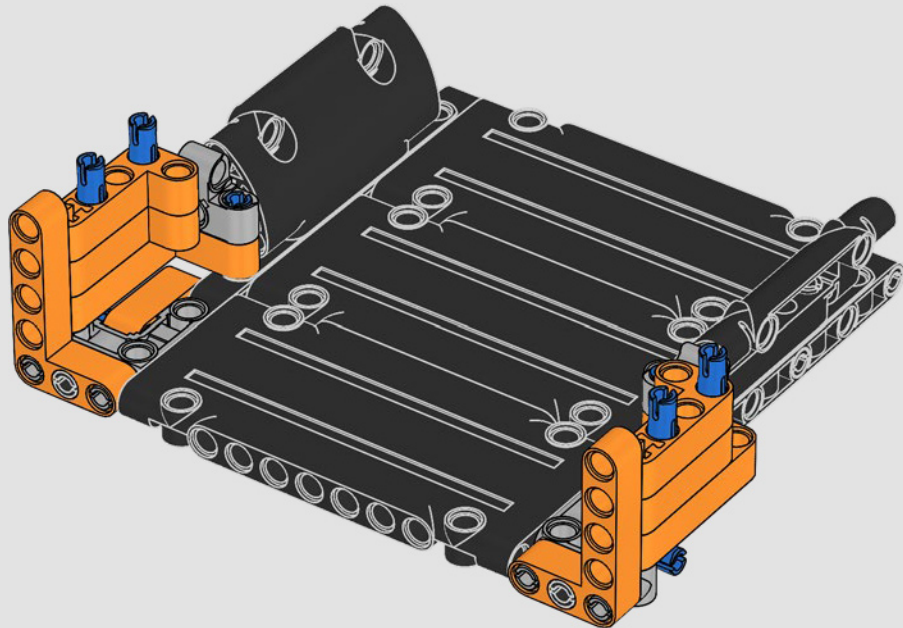

397

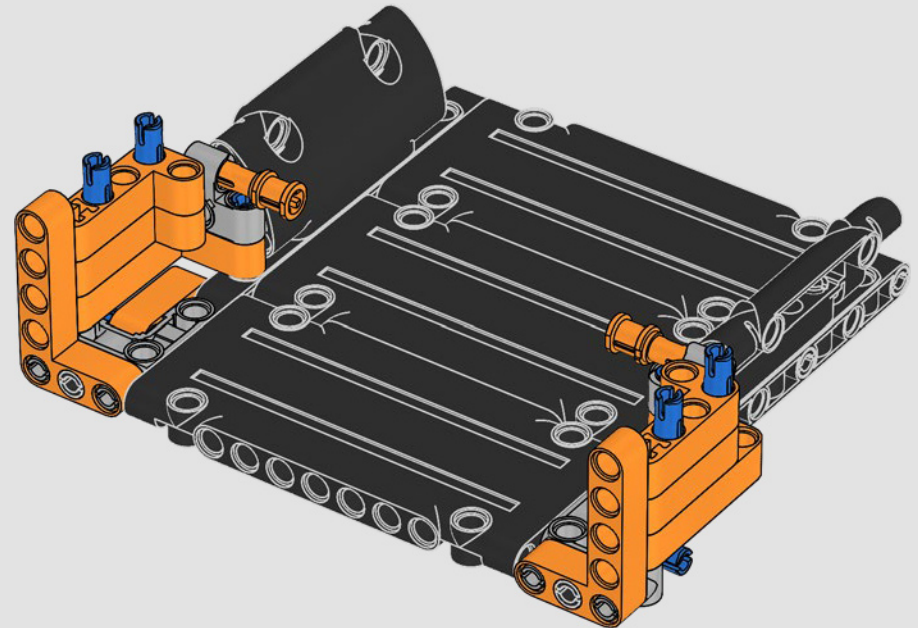

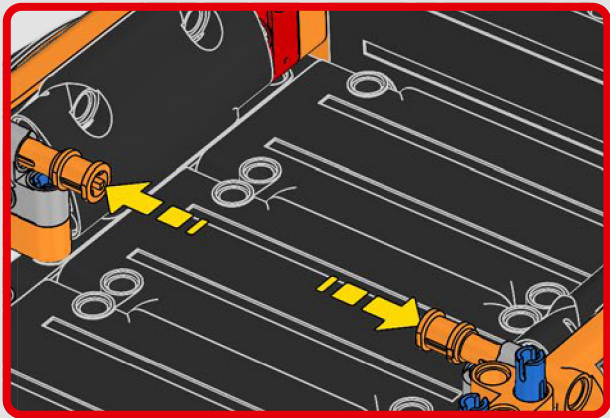

398

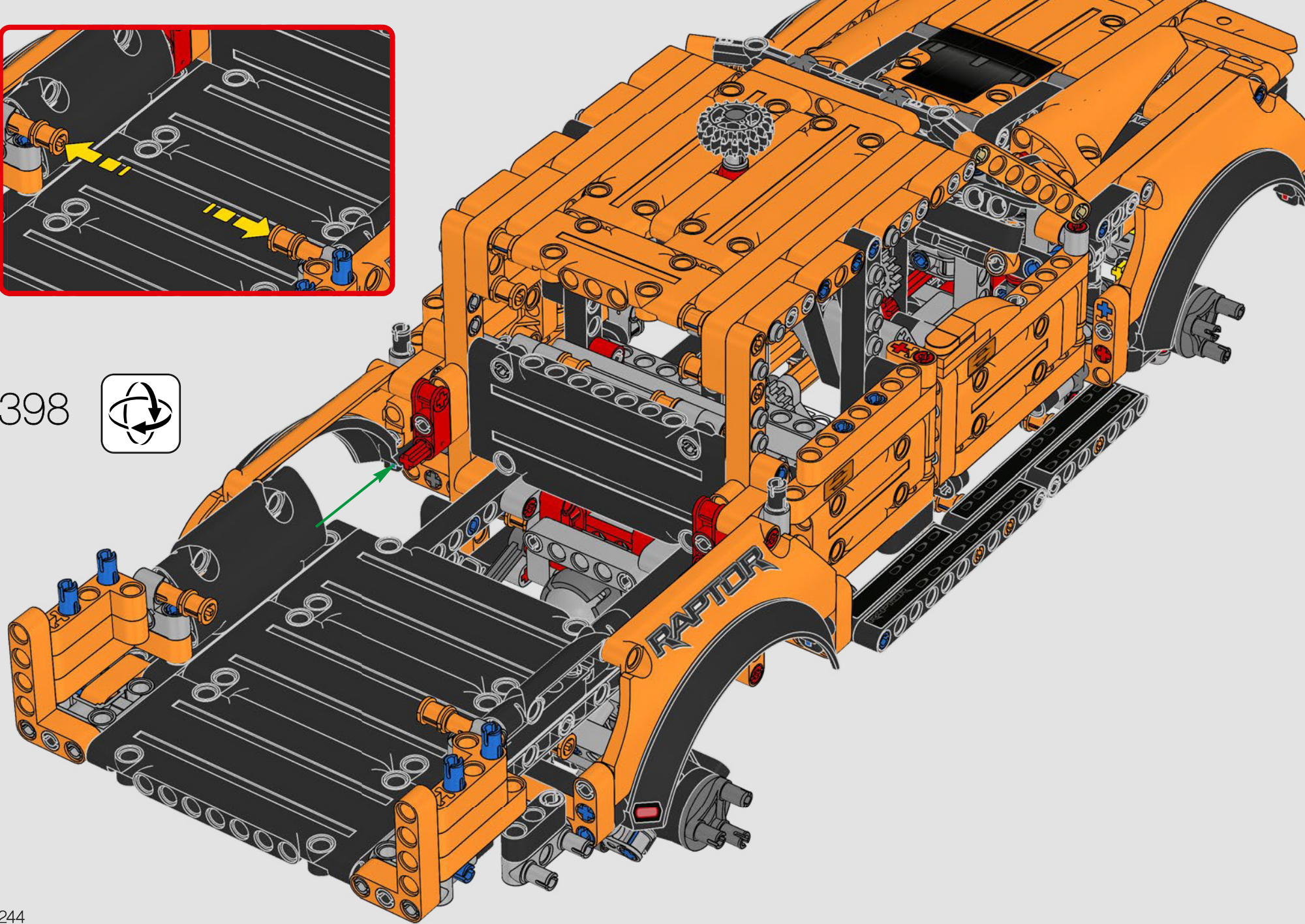

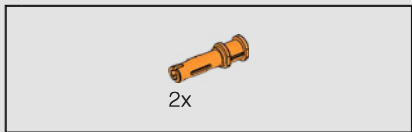

399

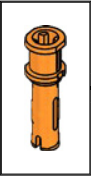
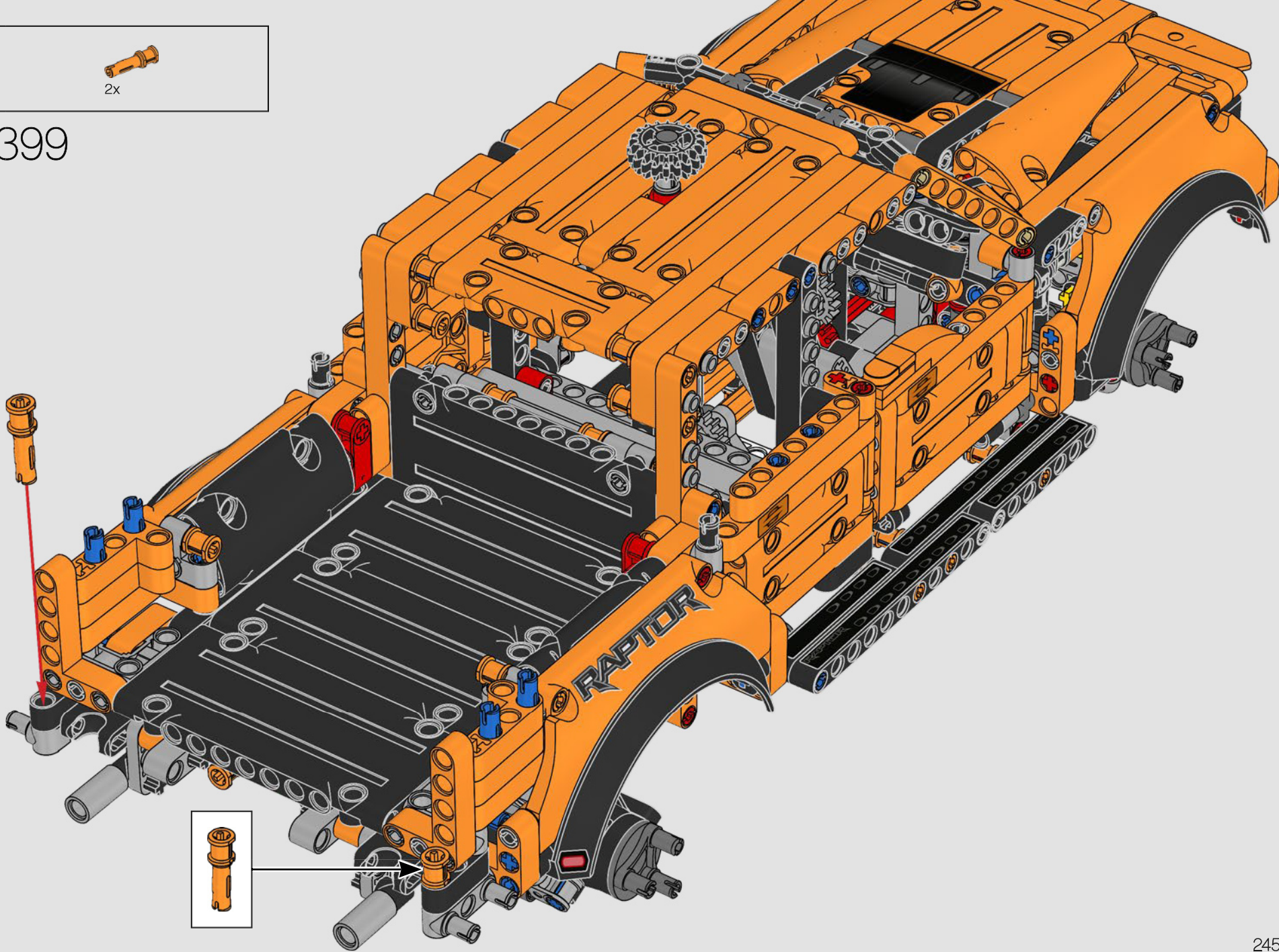

8x

400

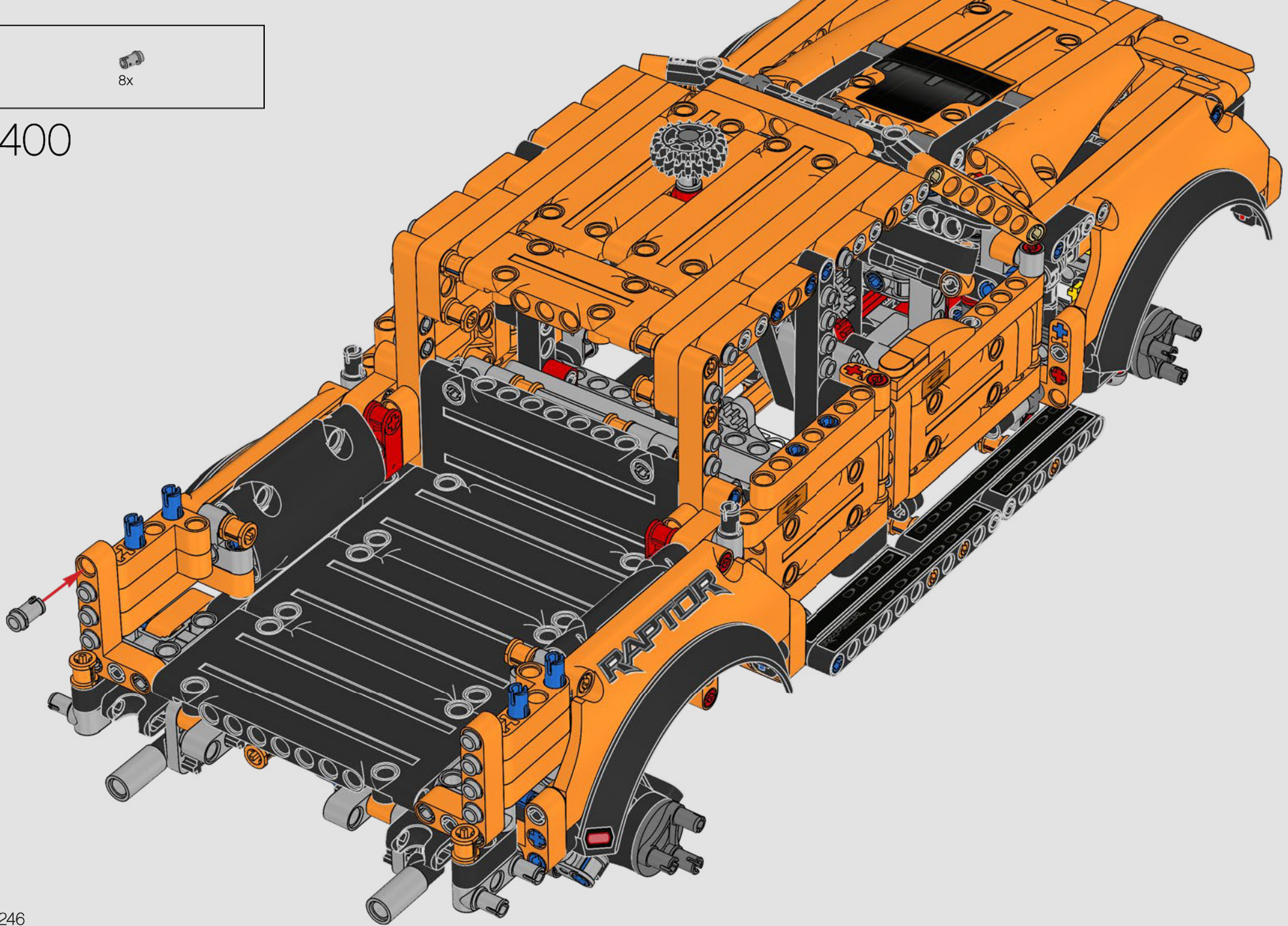



401

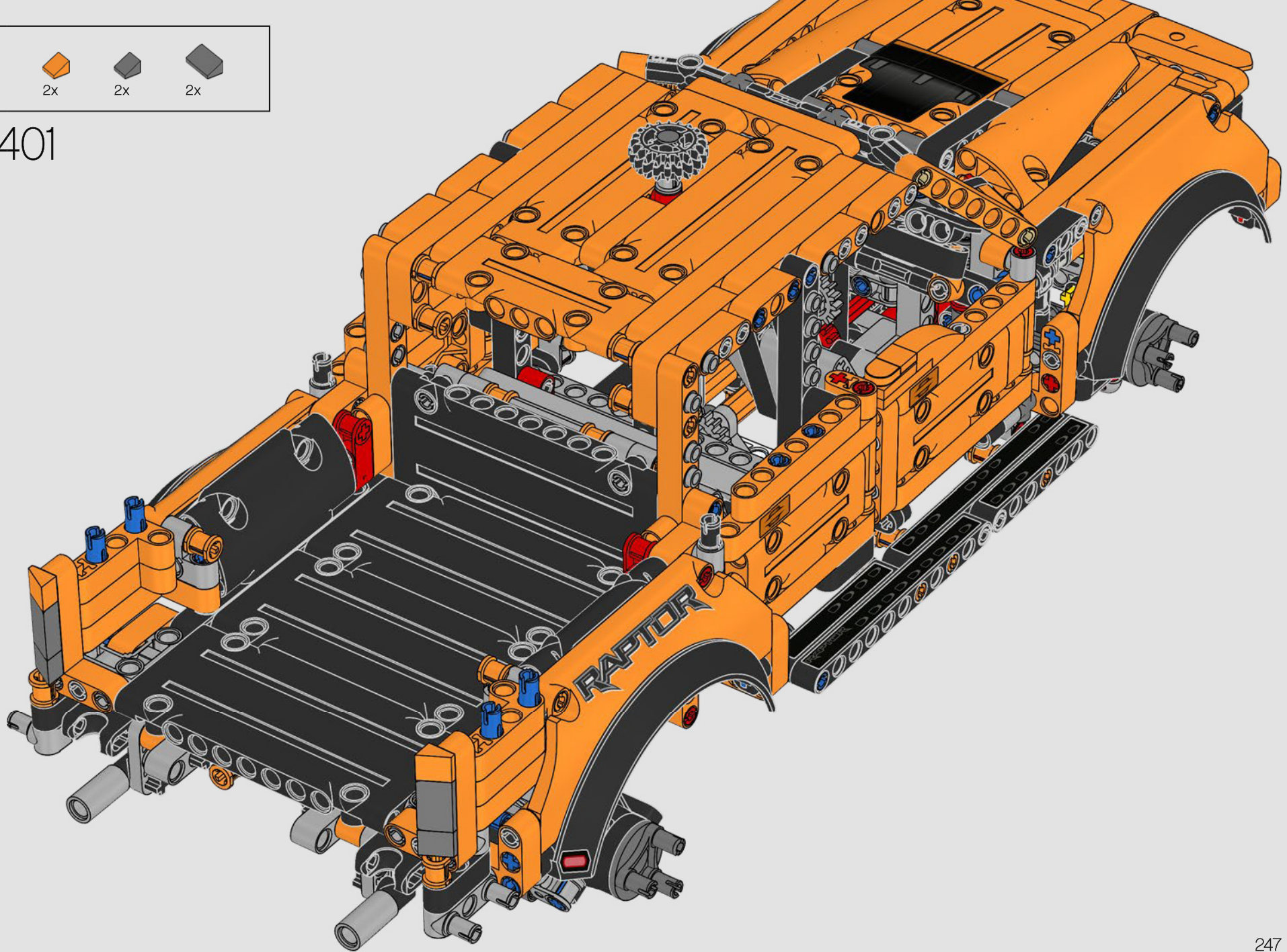

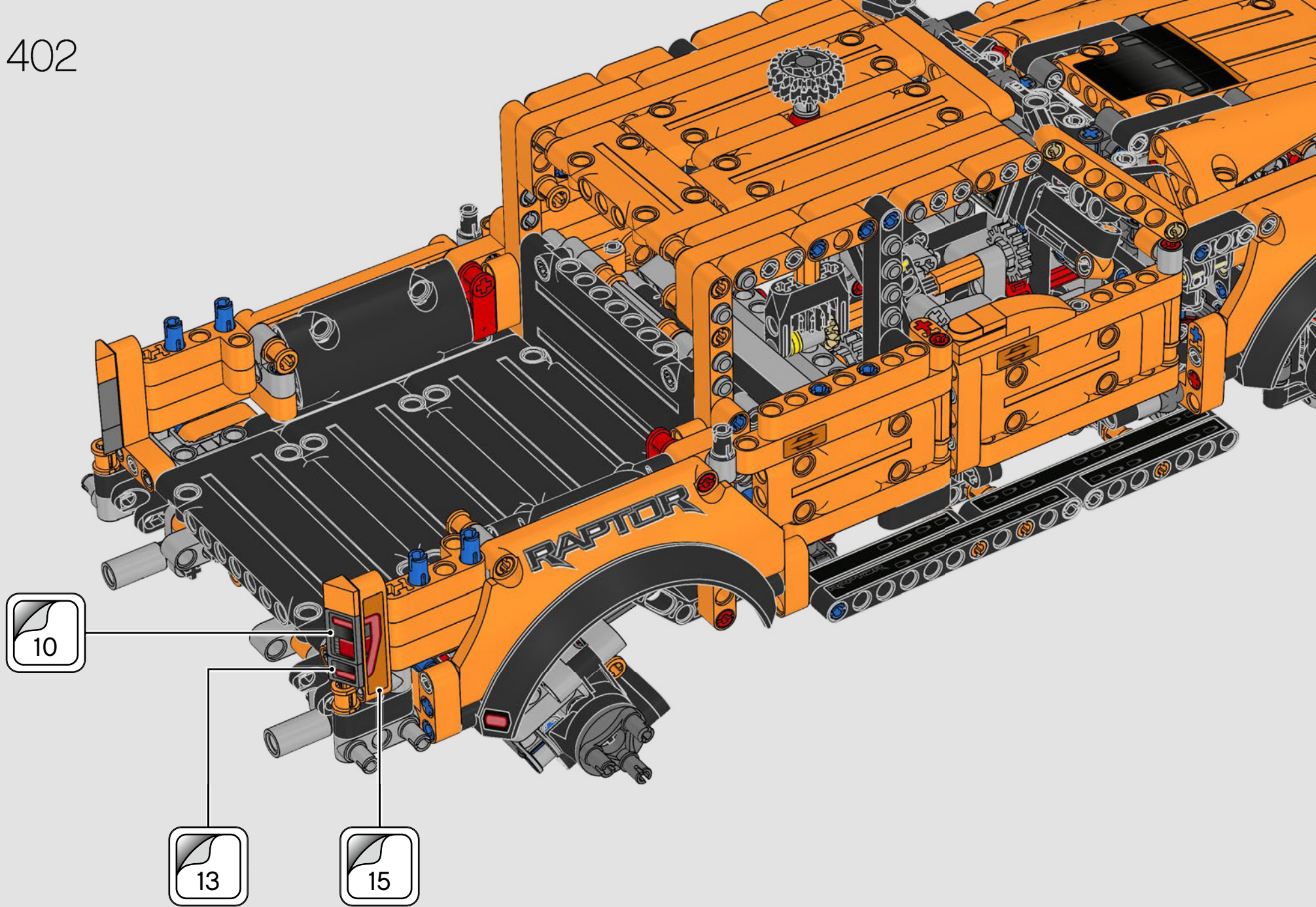

10

13

15



403

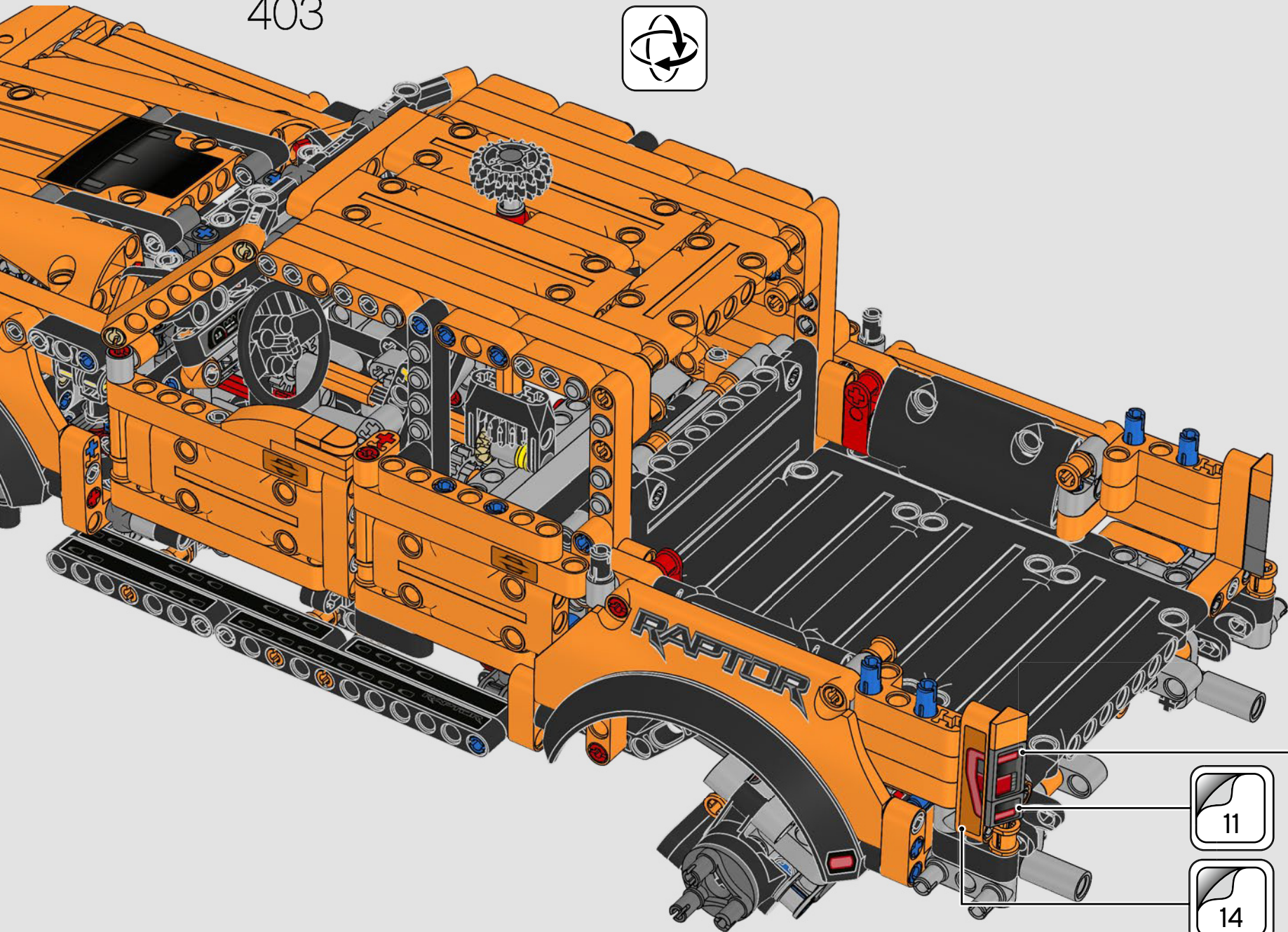
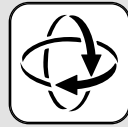

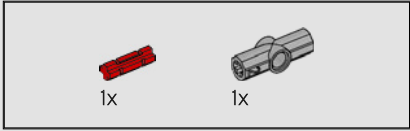
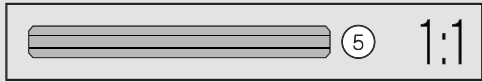
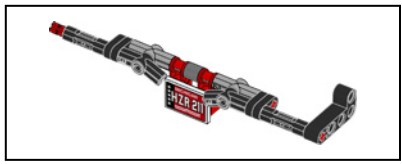

404

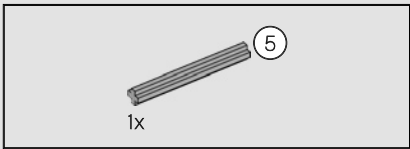
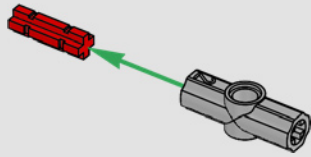

405

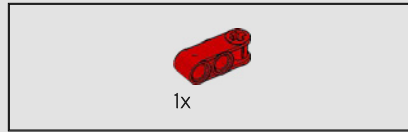
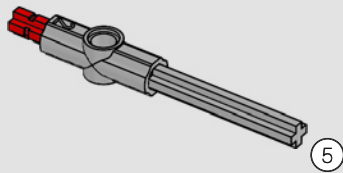

406

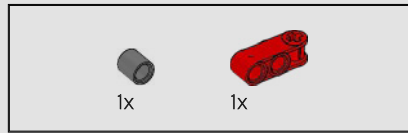
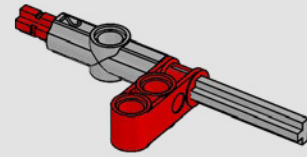

407

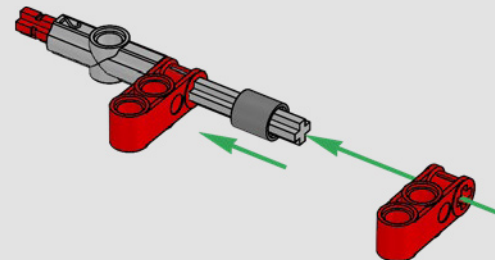

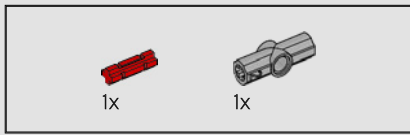

408

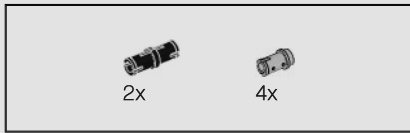
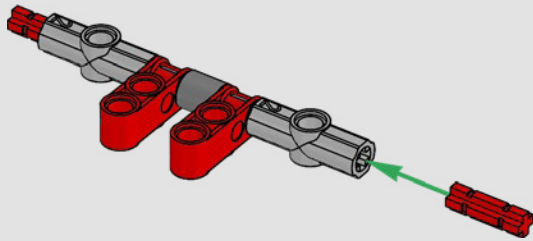

409

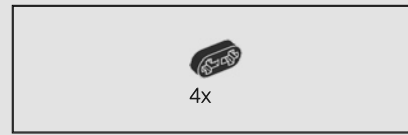
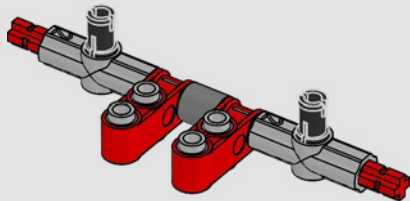

410

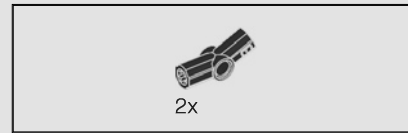
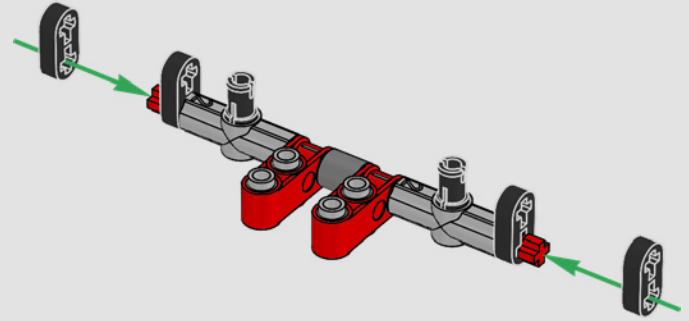

411

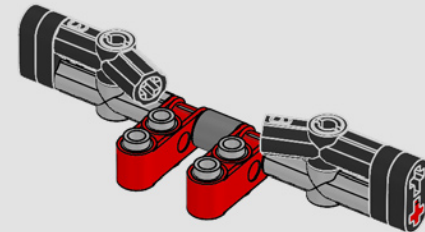

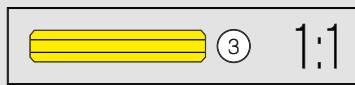
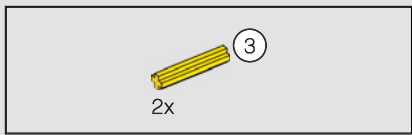

412

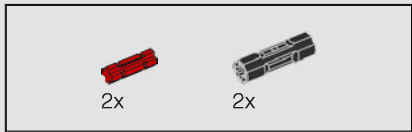
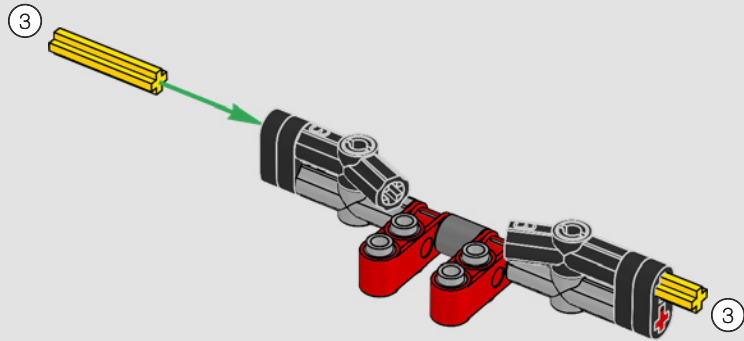

413

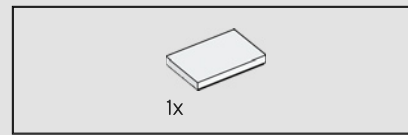
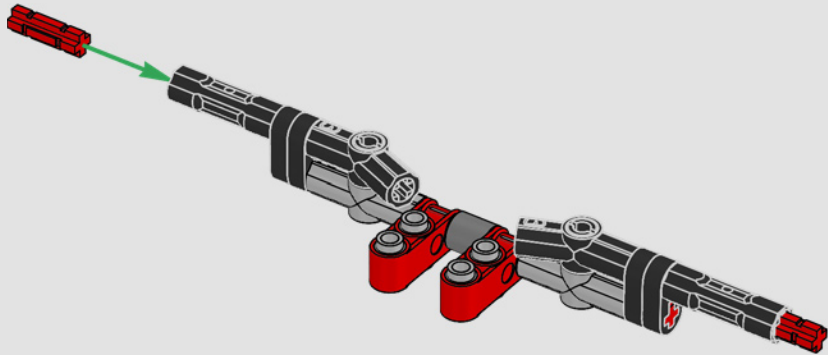

414

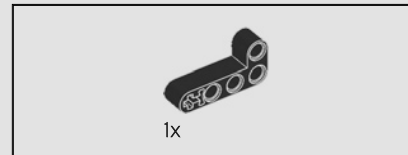
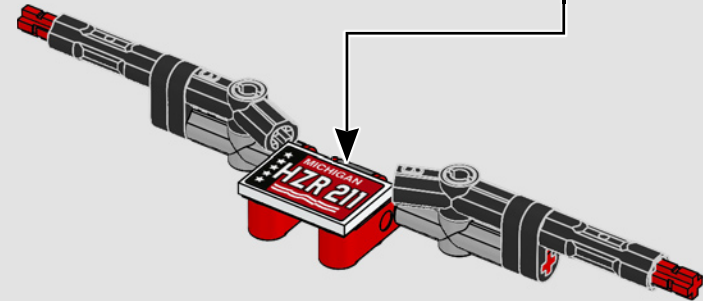
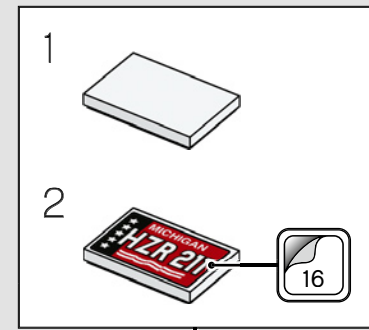

415

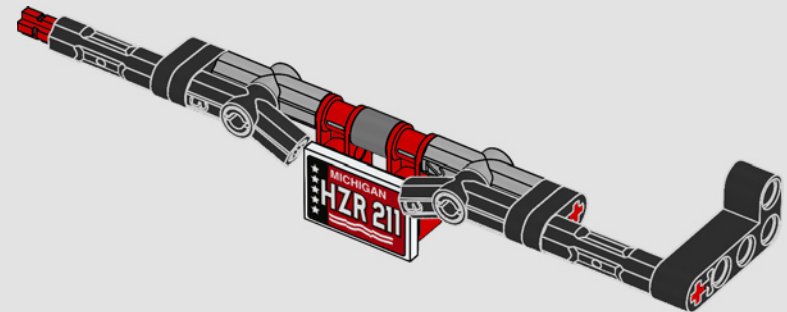
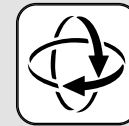

416

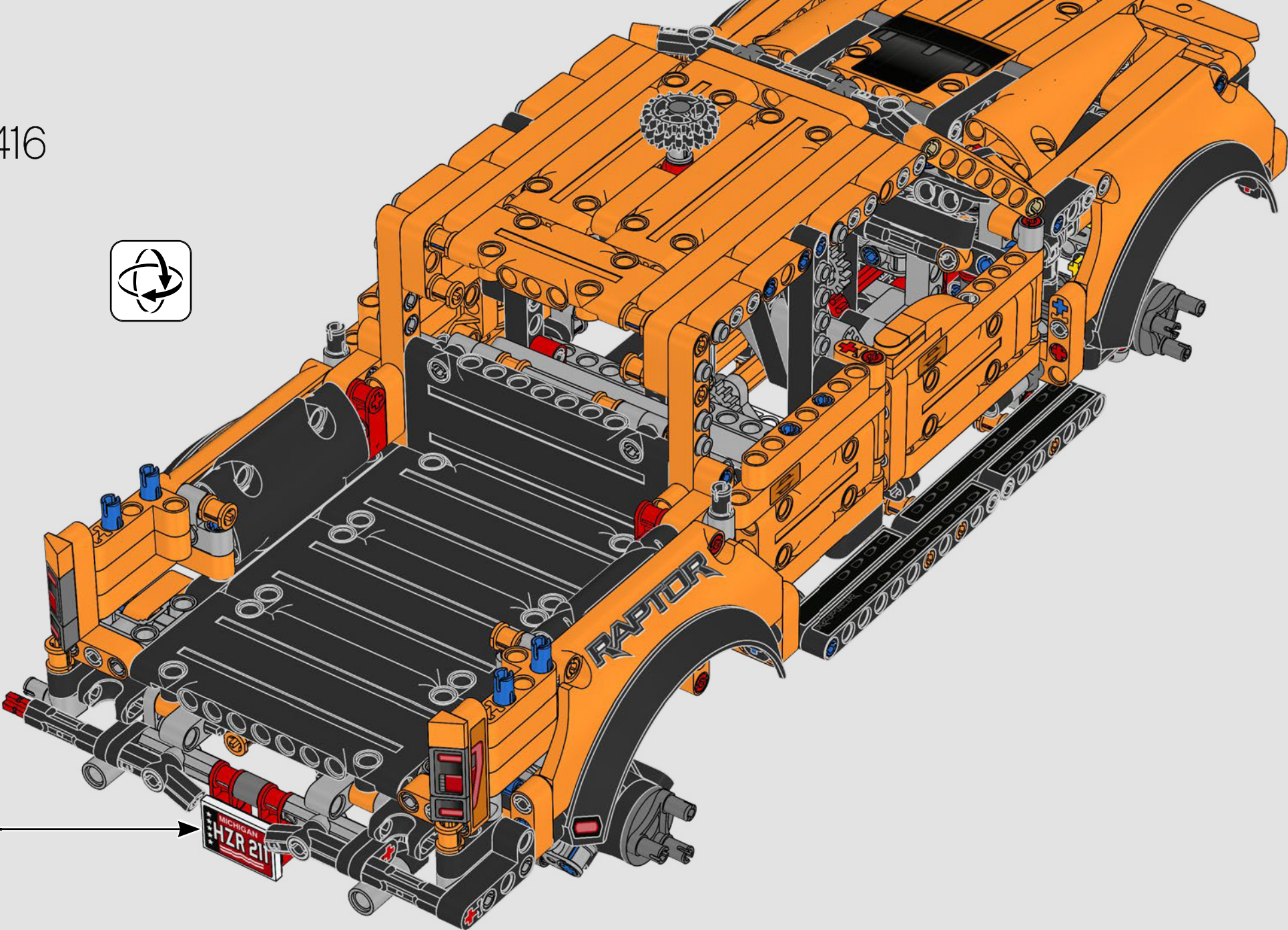

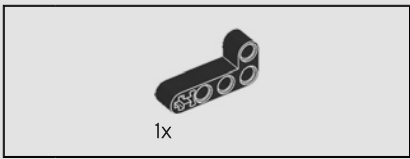

417

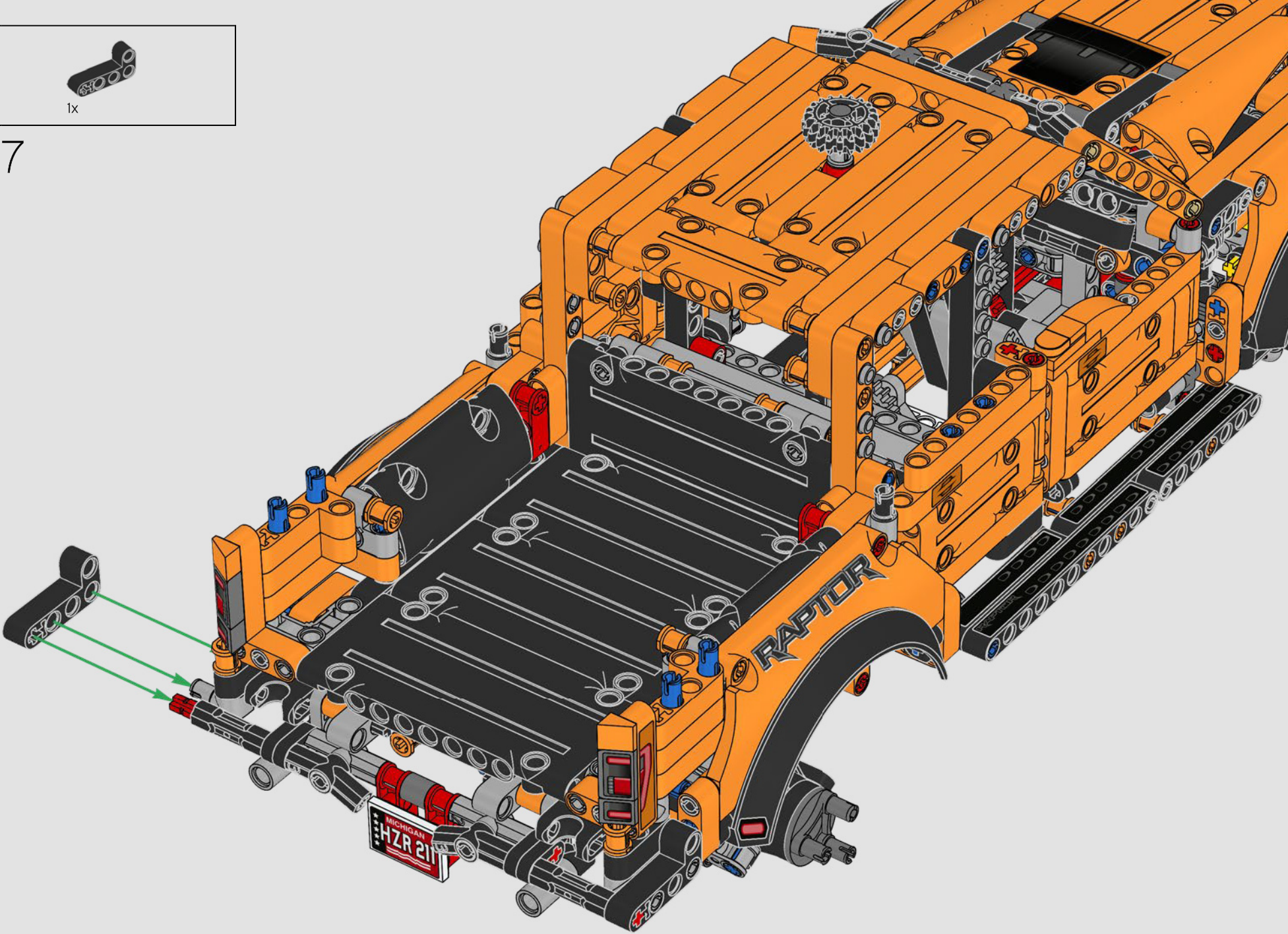

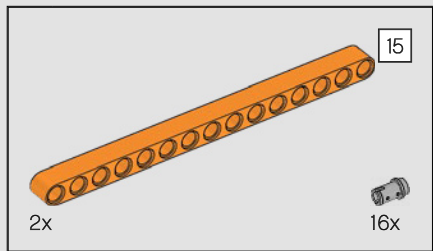

418

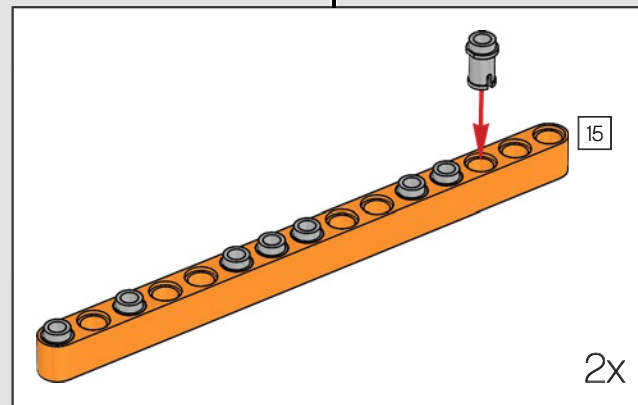
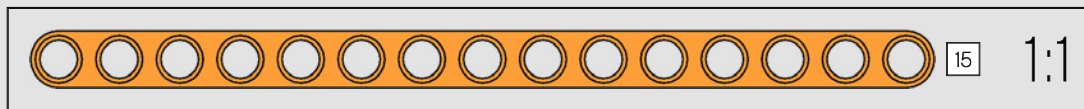
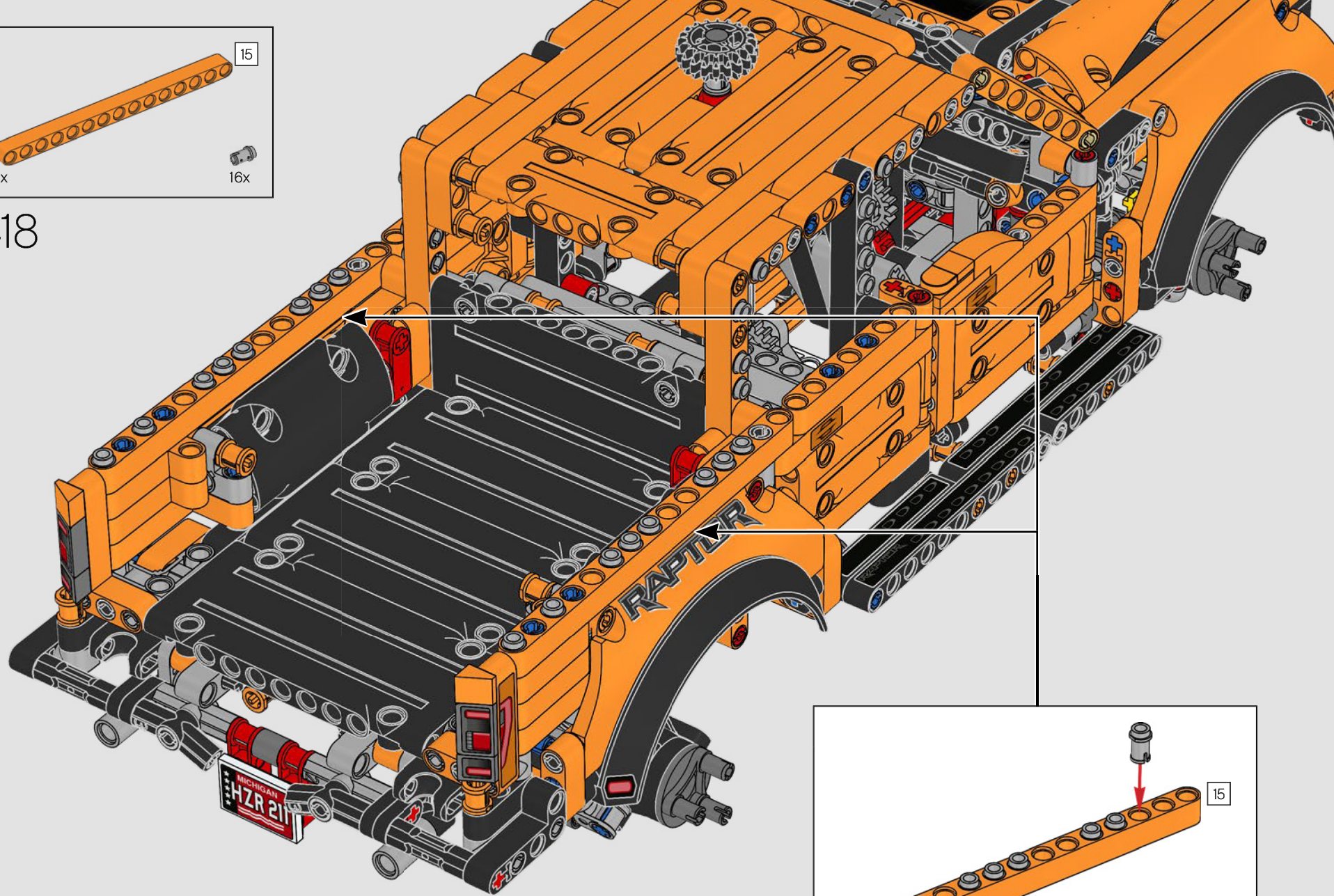

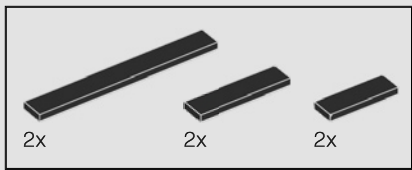

419

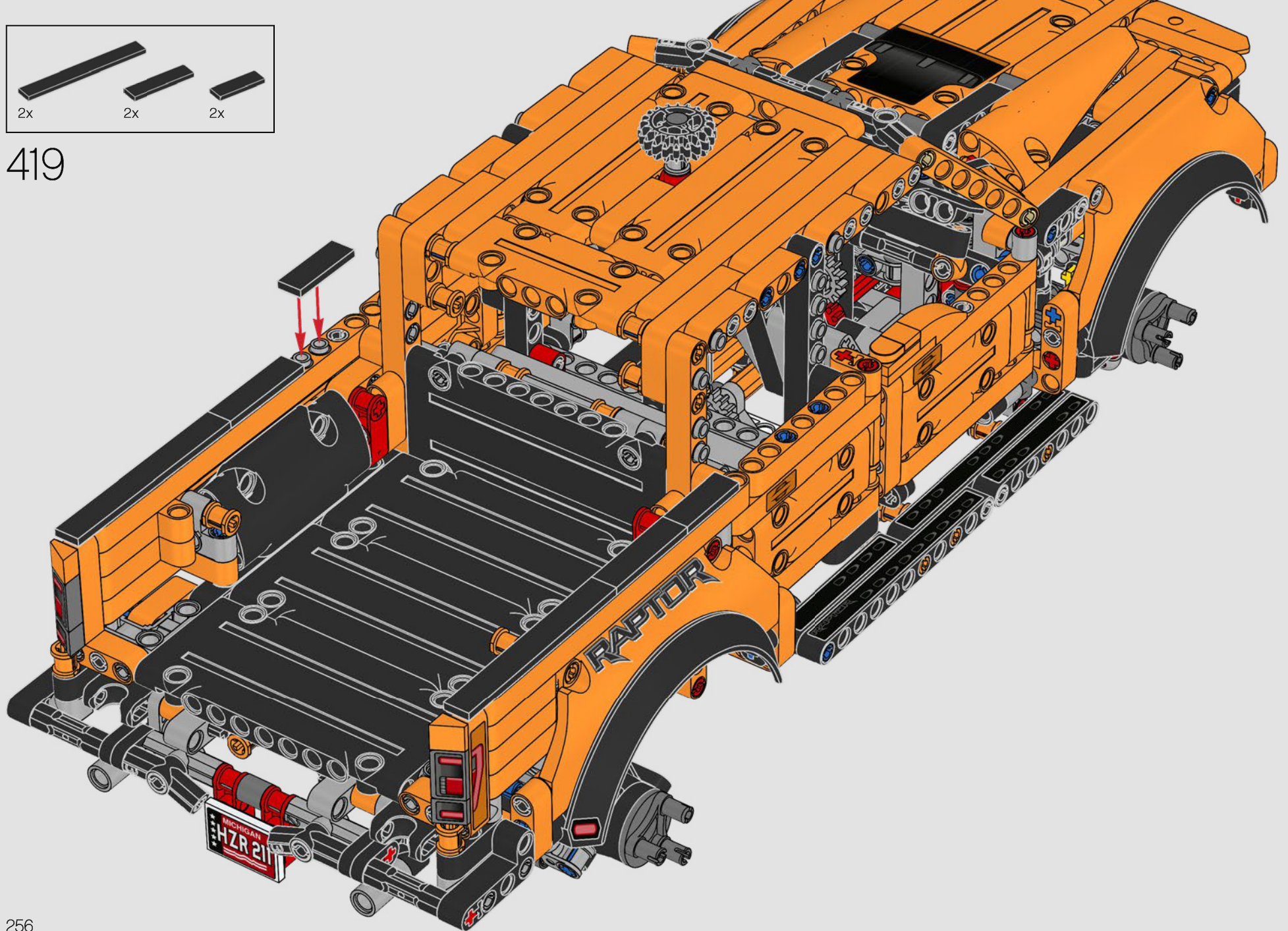



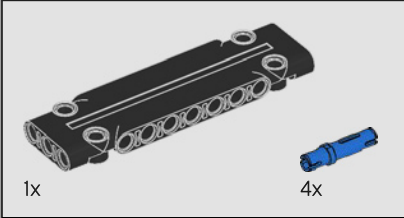
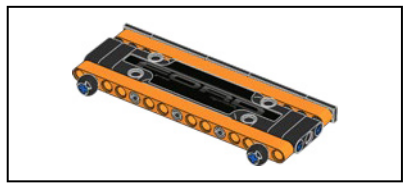

420

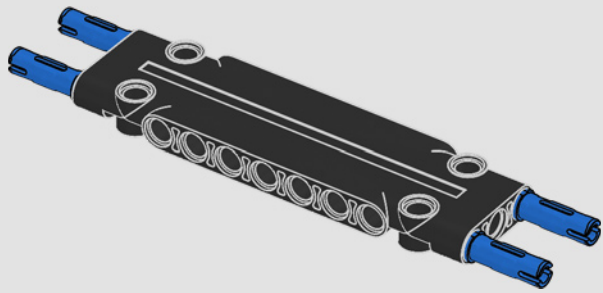

421

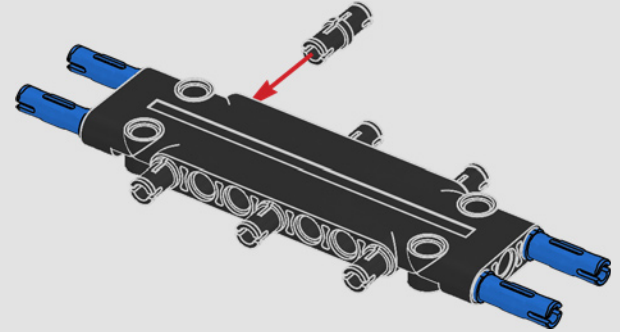

422

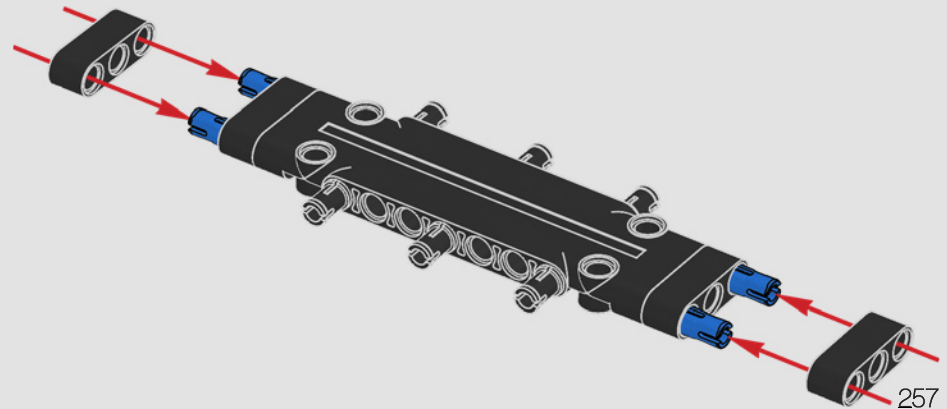

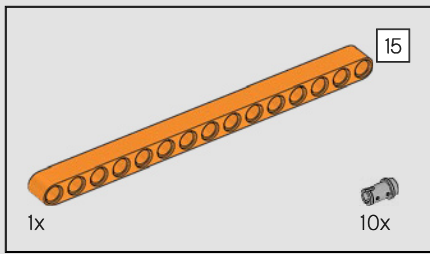

423

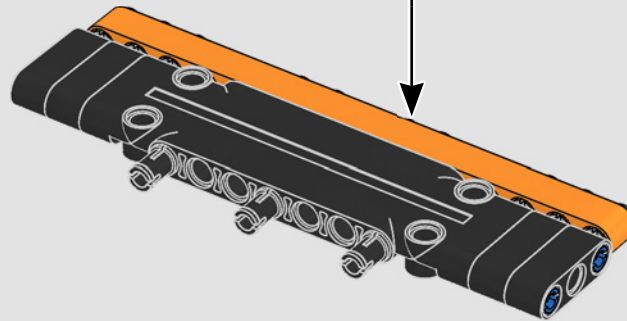
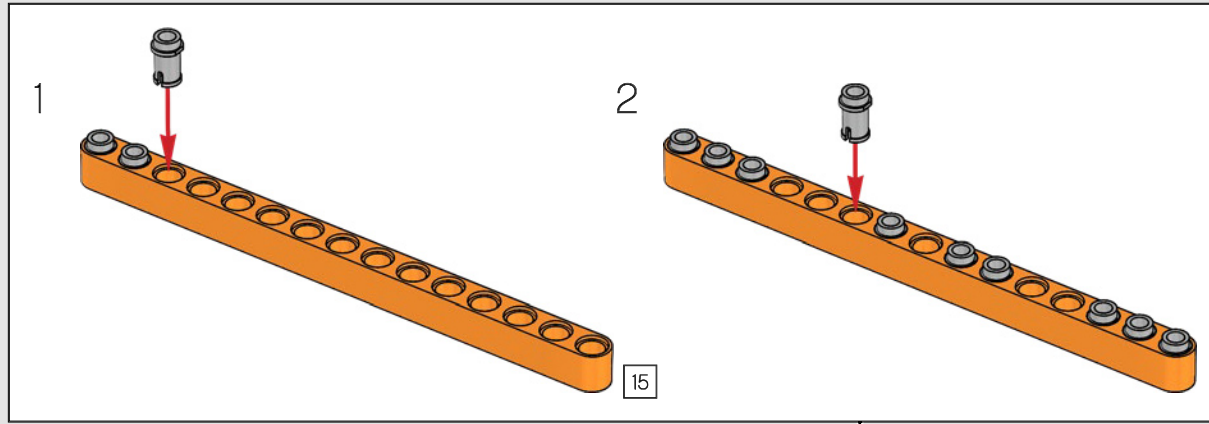
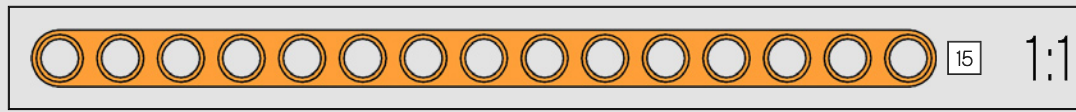

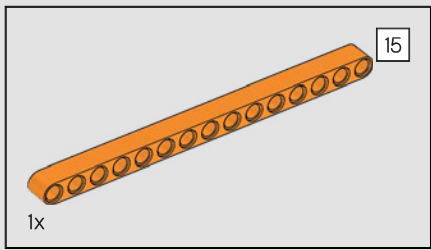

424

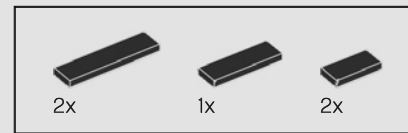
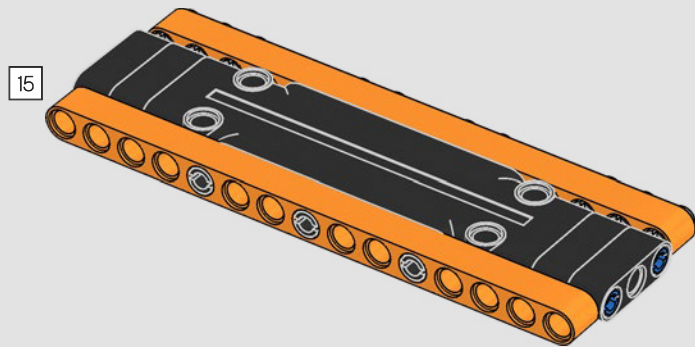

425

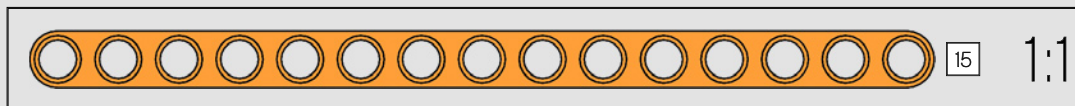
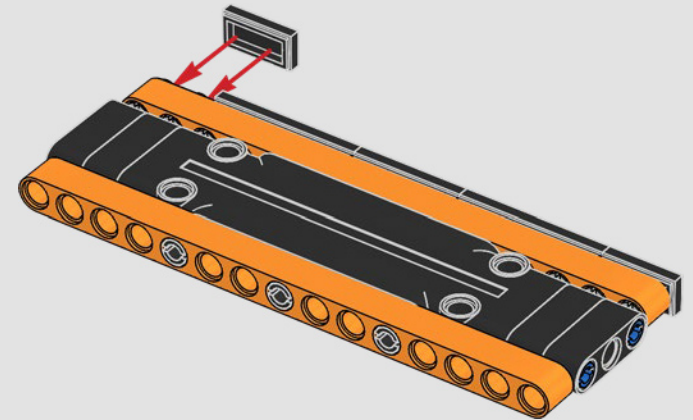

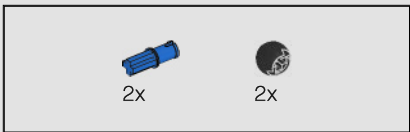

426

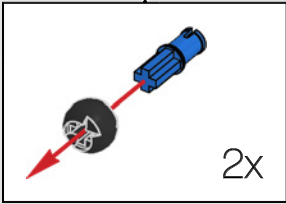
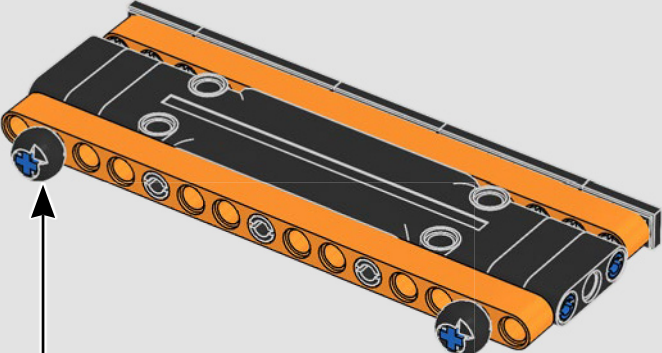

427

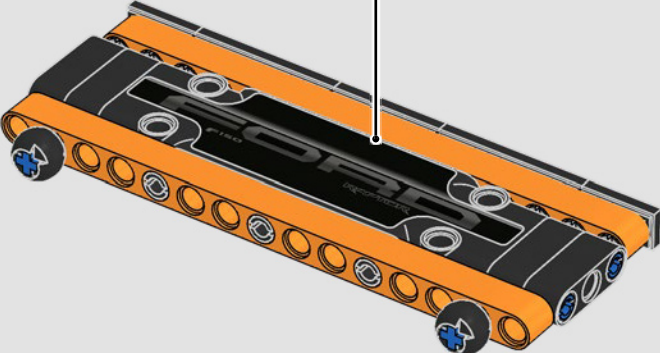

428

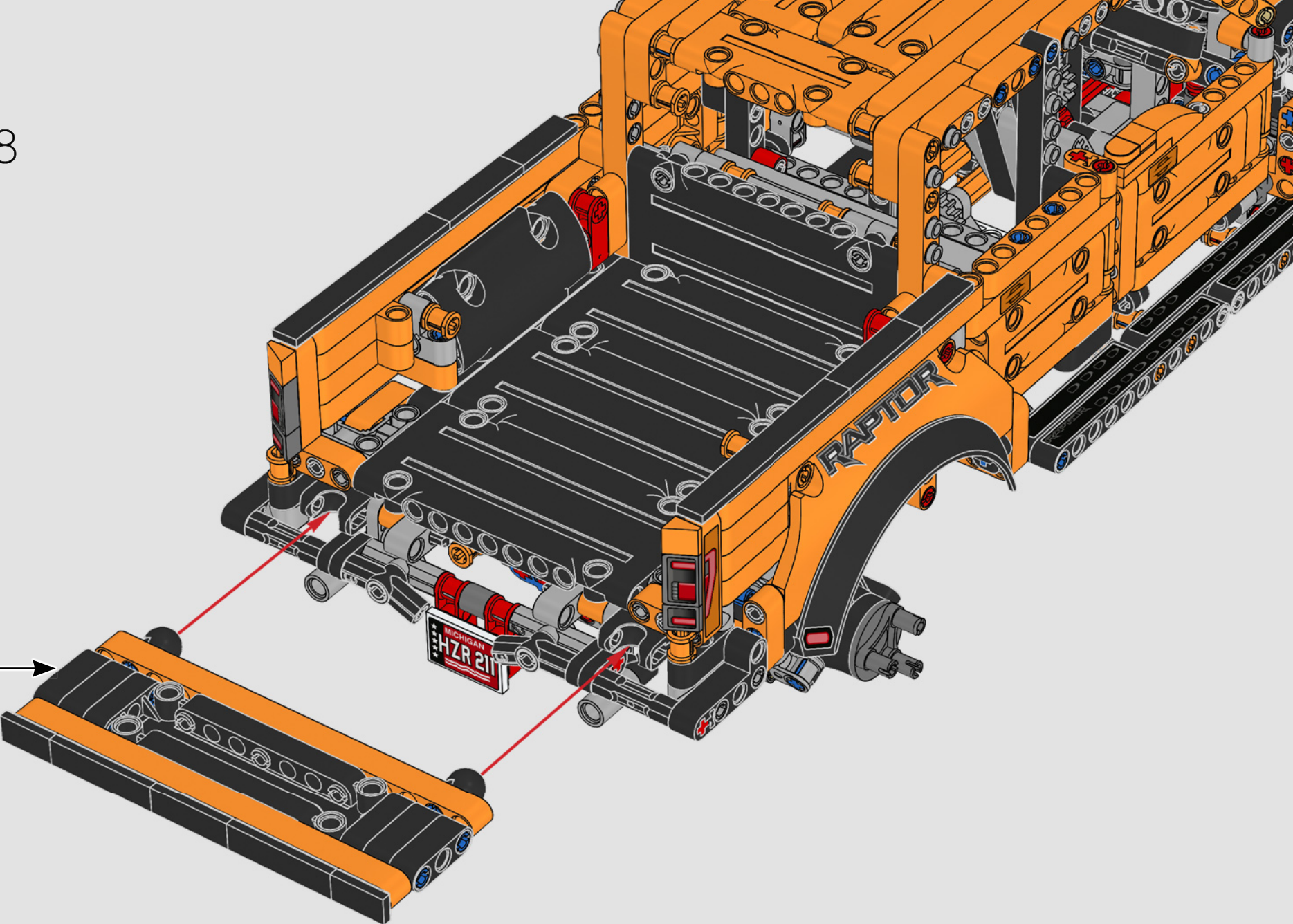

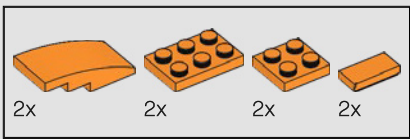

429

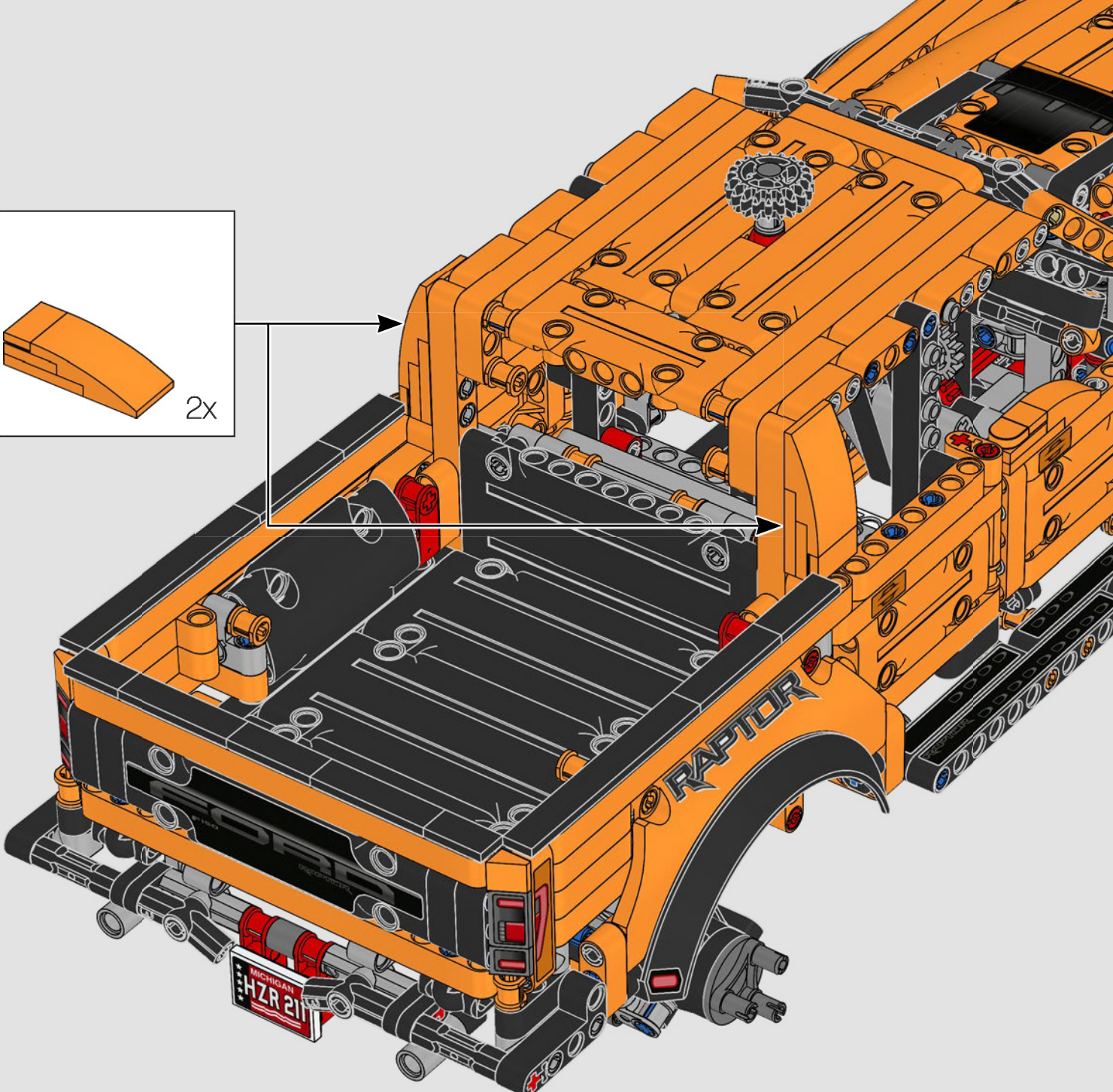
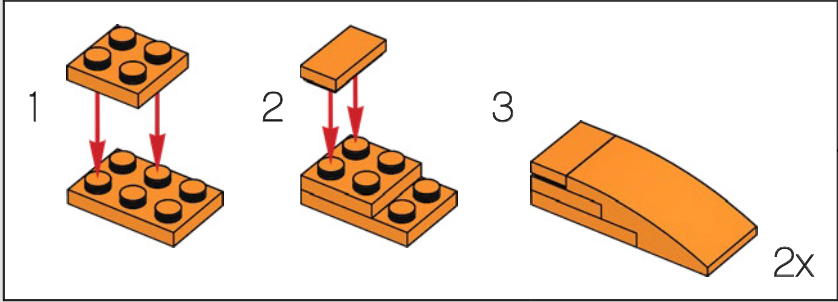

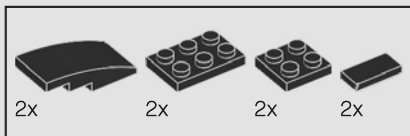

430

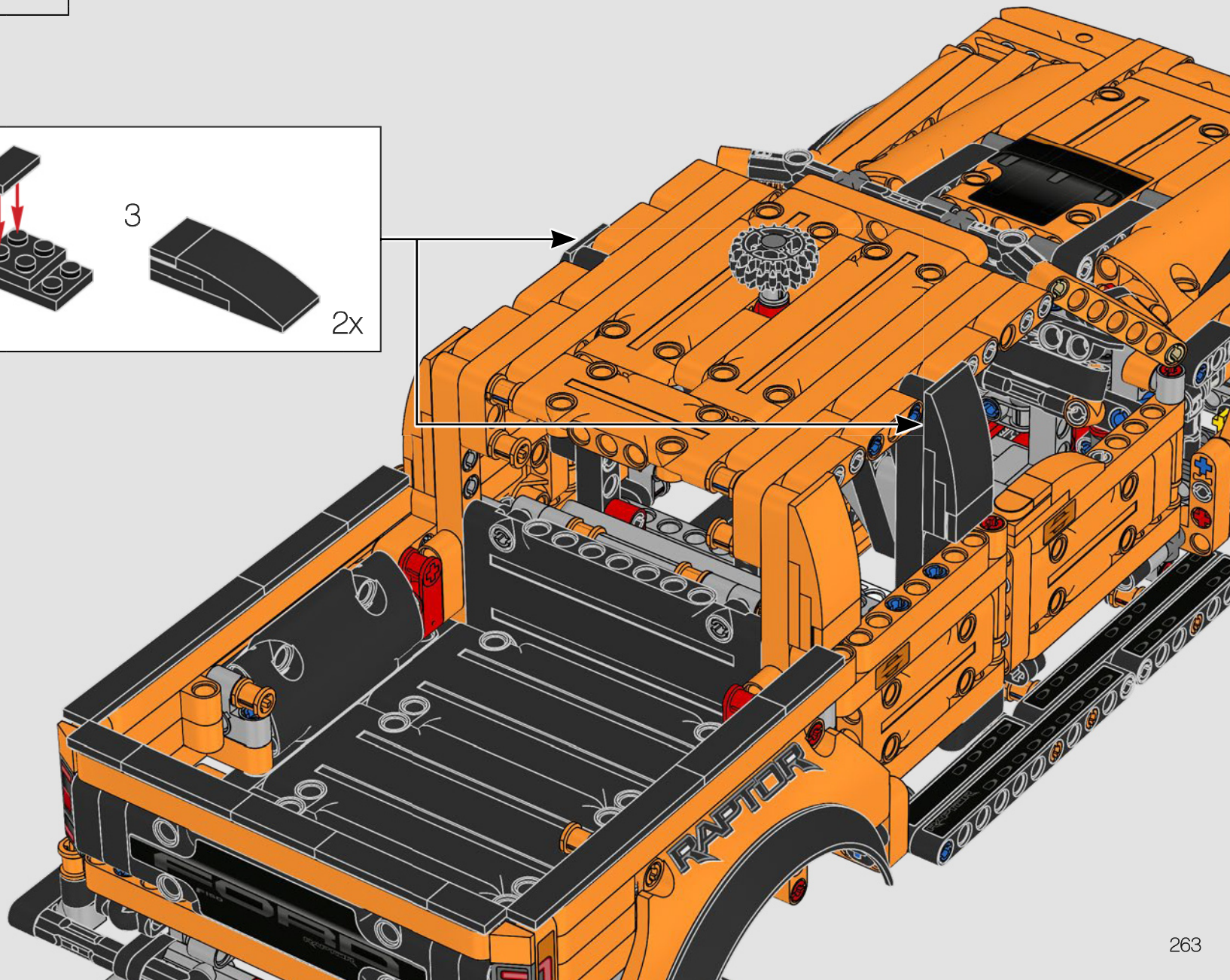
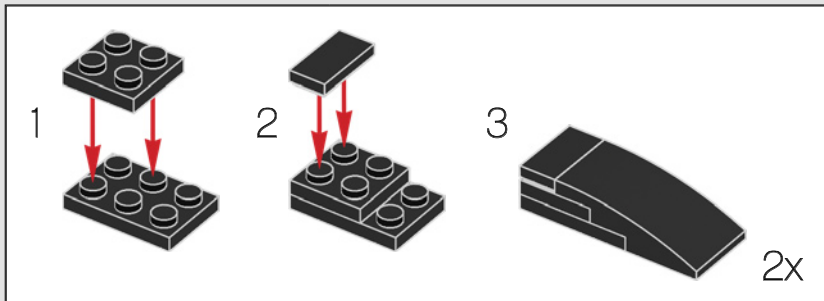

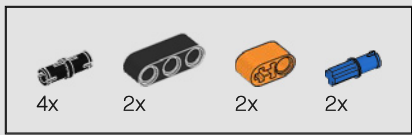

431

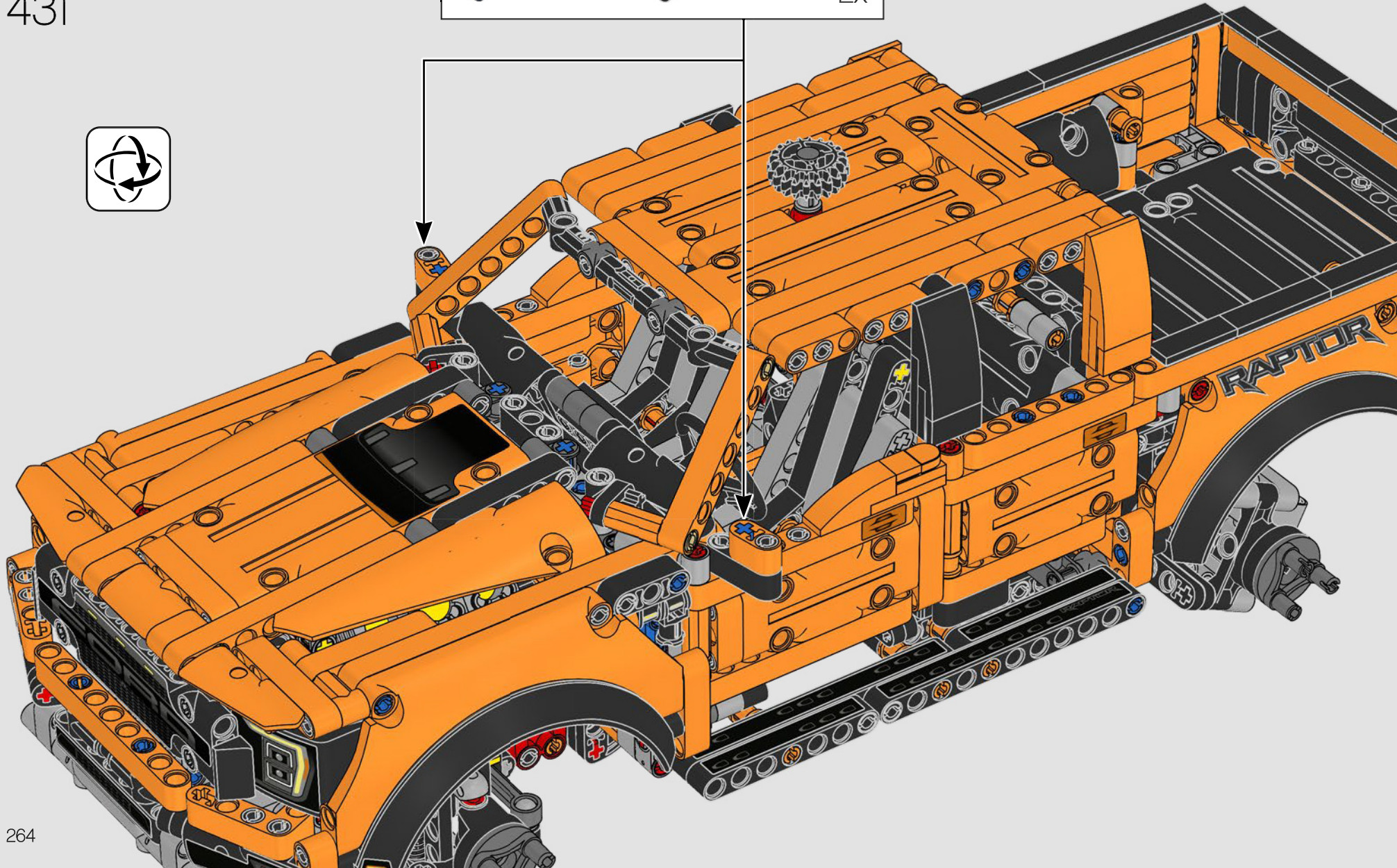
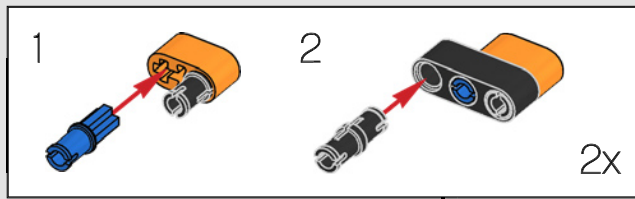



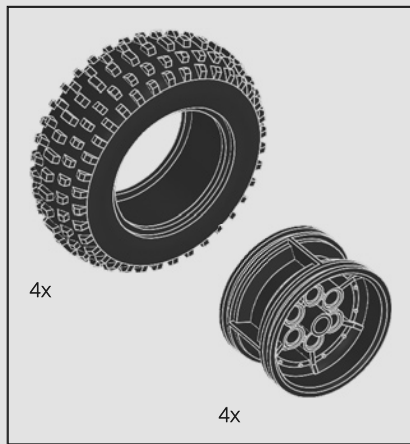

432

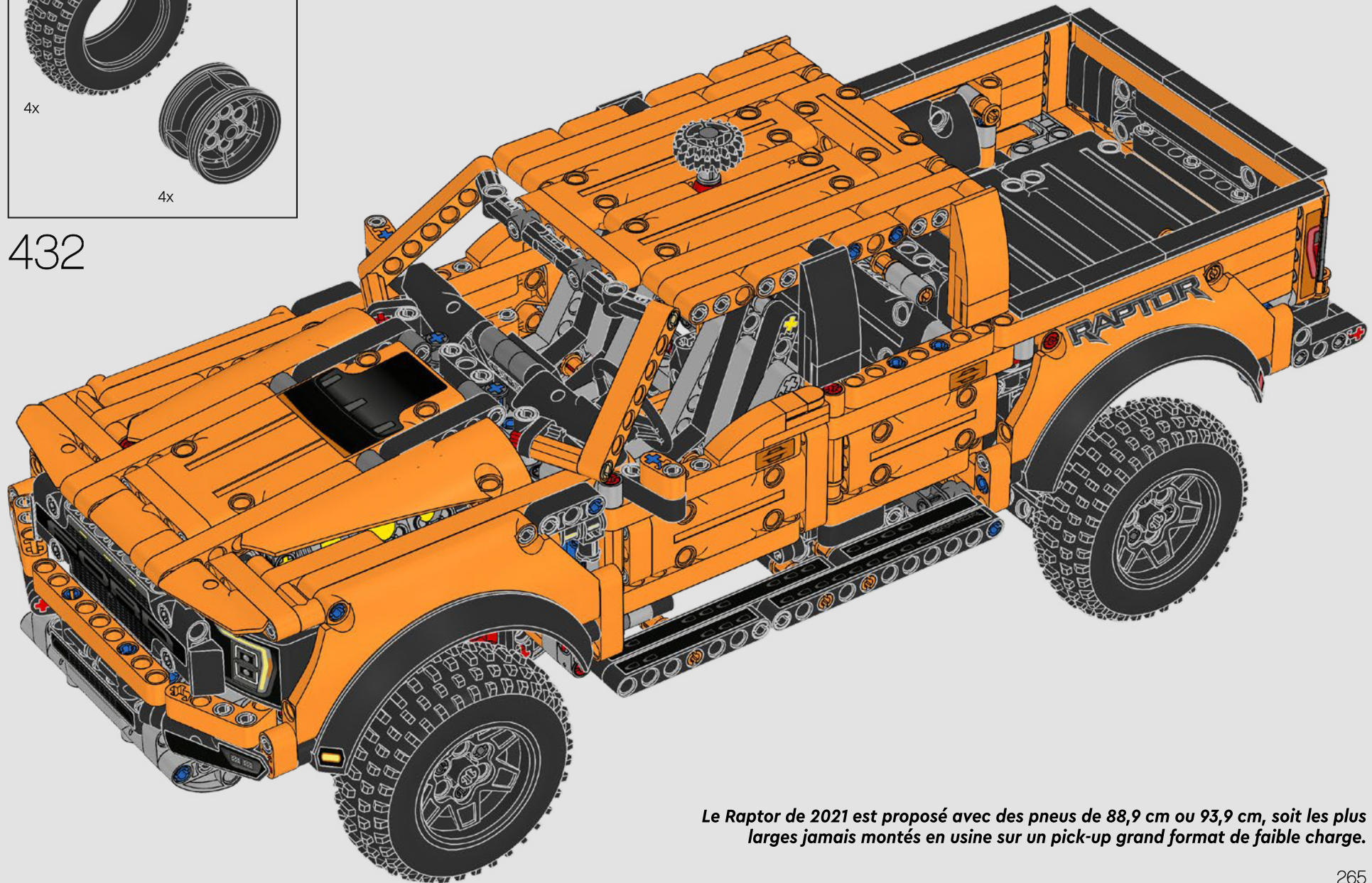

*Le Raptor de 2021 est proposé avec des pneus de 88,9 cm ou 93,9 cm, soit les plus larges jamais montés en usine sur un pick-up grand format de faible charge.*



3x 6275844  
 21x 6282142  
 69x 4211483  
 2x 4211375  
 21x 6261375  
 6x 4211880  
 2x 6173127  
 6x 4640536  
 2x 6361459  
 6x 6000018  
 2x 6360043  
 3x 6346487  
 3x 6282158  
 1x 6335279

6x 4234251  
 6x 6313453  
 24x 6271831  
 4x 6331428  
 4x 6247352  
 11x 4211639  
 16x 4211713  
 16x 4211651  
 2x 6055519  
 1x 6257136  
 4x 6279885

1x 6296843  
 9x 6102449  
 13x 6102449  
 3x 4522934  
 4x 4629802  
 2x 6338588  
 2x 6358258  
 1x 4580014  
 6x 6358259

1x 6358253  
 1x 6358255  
 2x 4125278  
 1x 6358254  
 4x 6305545  
 12x 6271832  
 2x 6054529  
 11x 6135086  
 2x 6339023

2x 6344851  
 6x 6332584  
 6x 6259825  
 14x 6265128  
 20x 6143028  
 2x 4251969  
 2x 6147047  
 3x 6143014  
 14x 6143015  
 7x 6339024  
 5x 6358256

2x 6332570  
 53x 4206482  
 2x 6331024  
 6x 6279026  
 128x 6299413  
 2x 4558595  
 2x 4504371  
 1x 6352662  
 1x 6340604  
 2x 4177932  
 2x 4188771  
 2x 4159007  
 43x 6347790  
 17x 6102618

2x 6271167  
 6x 4112203  
 2x 4119474  
 21x 6130007  
 1x 6130009  
 22x 6100030  
 2x 4504378  
 2x 4567887  
 2x 6280395  
 10x 6167281  
 1x 6296844

10x 6276984  
 4x 4610378  
 9x 6083620  
 1x 4525184  
 3x 4508553  
 4x 4629920  
 2x 6027566  
 2x 6027565

Customer Service  
 Kundenservice  
 Service Consommateurs  
 Servicio Al Consumidor  
 LEGO.com/service or dial  
 : 00800 5346 5555  
 : 1-800-422-5346



# FEEDBACK AND WIN



## FEEDBACK AND WIN

Your feedback will help shape the future development of this product series.

Please visit:

## FEEDBACK UND GEWINNEN

Dein Feedback trägt zur Weiterentwicklung dieser Produktreihe bei.

Geh auf:

## COMMENTEZ ET GAGNEZ

Vos commentaires nous aideront à concevoir les futurs produits de cette gamme.

Rendez-vous sur :

## COMENTA Y GANA

Tu opinión nos ayudará a dar forma al desarrollo de esta serie de productos en el futuro.

Visita:

## 反馈有奖

您的反馈将有助于我们在今后改进本系列产品。

请访问：

[LEGO.com/productfeedback](https://www.lego.com/productfeedback)

By completing, you will automatically enter a drawing to win a LEGO® set.

Terms & Conditions apply.

Durch Ausfüllen nimmst du automatisch an der Verlosung eines LEGO® Preises teil.

Es gelten die Teilnahmebedingungen.

En envoyant vos commentaires, vous serez automatiquement inscrit(e) à un tirage au sort qui vous permettra de remporter un prix LEGO®.

Offre soumise à conditions.

Al contestar, participarás automáticamente en el sorteo y podrás ganar un set LEGO®.

Sujeto a Términos y Condiciones.

完成我们的反馈调查，即可自动进入抽奖环节，赢取乐高®套装。

适用《条款和条件》。

LEGO and the LEGO logo are trademarks of the LEGO Group. ©2021 The LEGO Group.

Ford Trademarks and Trade Dress used under license to The LEGO Group of companies.

