



CITY

7239







1

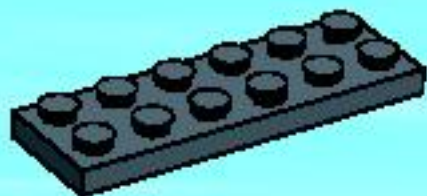

2

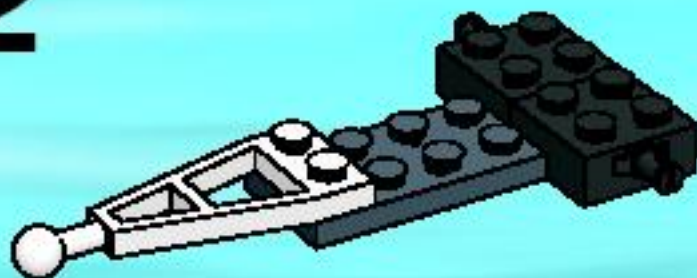

3

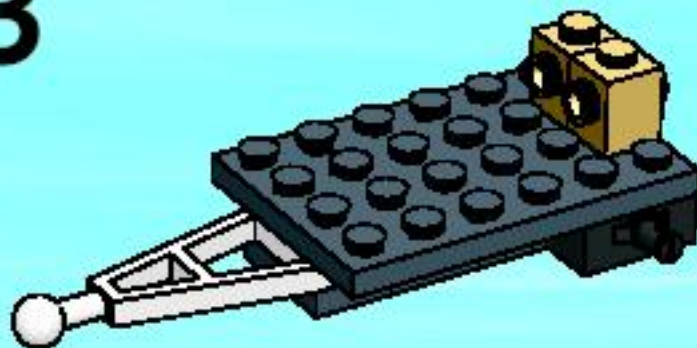

4



5



1

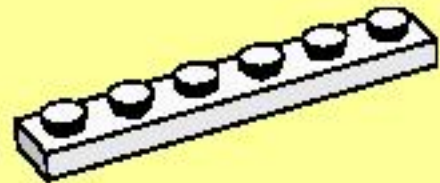

2

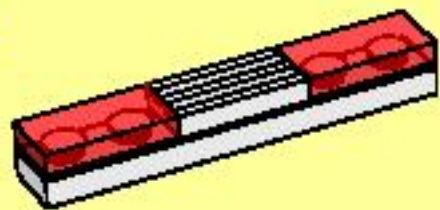

6

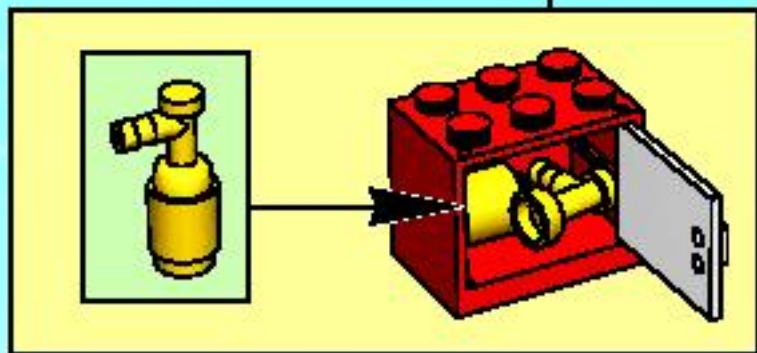
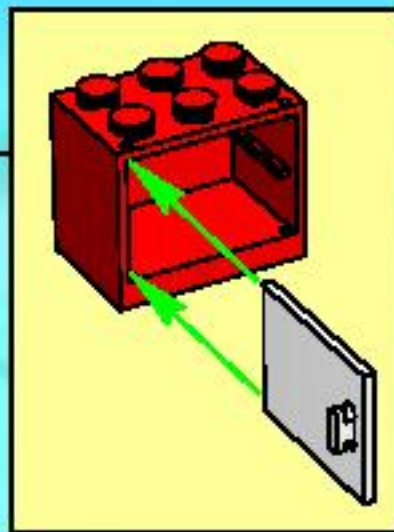

7





1

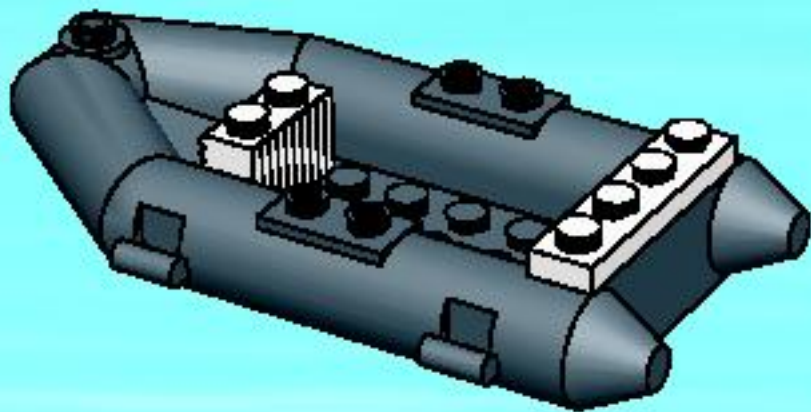

2

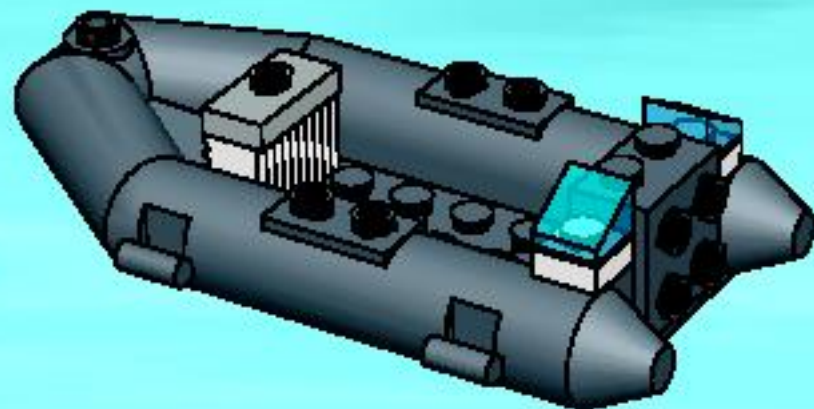

3

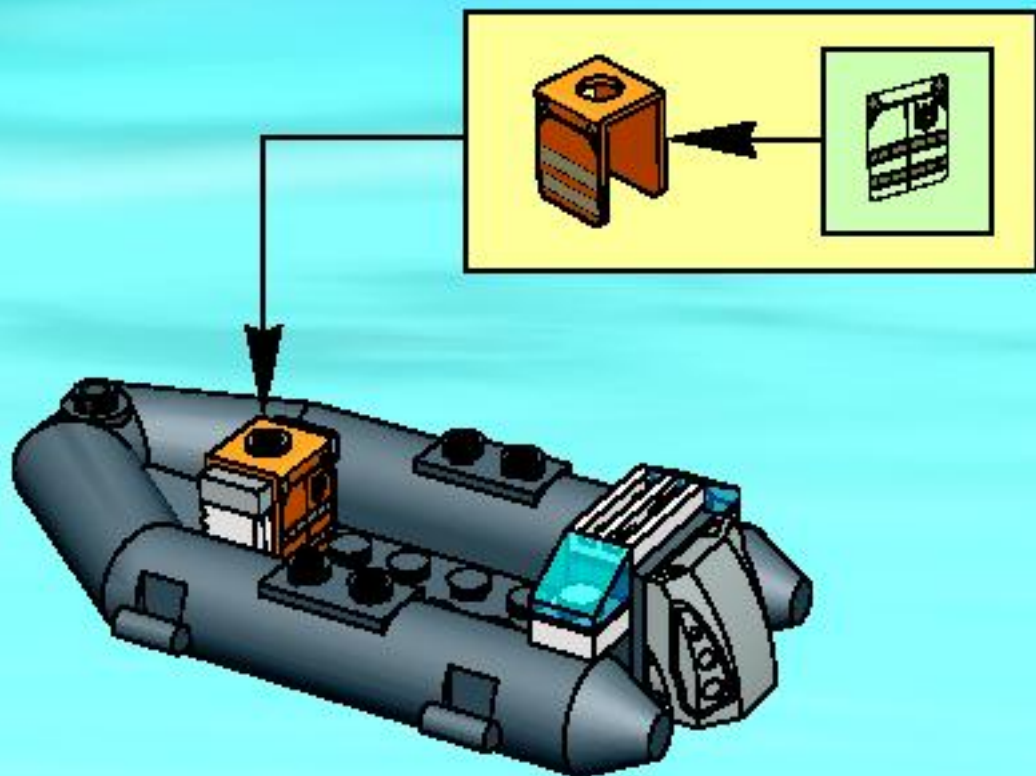

4

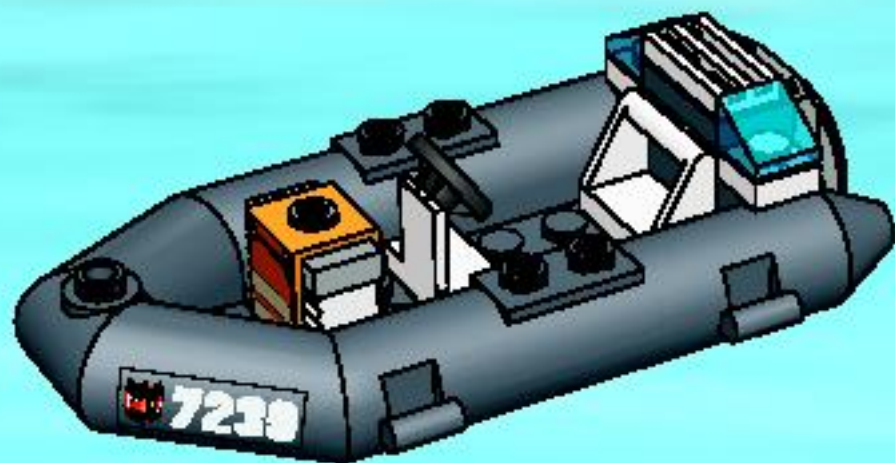

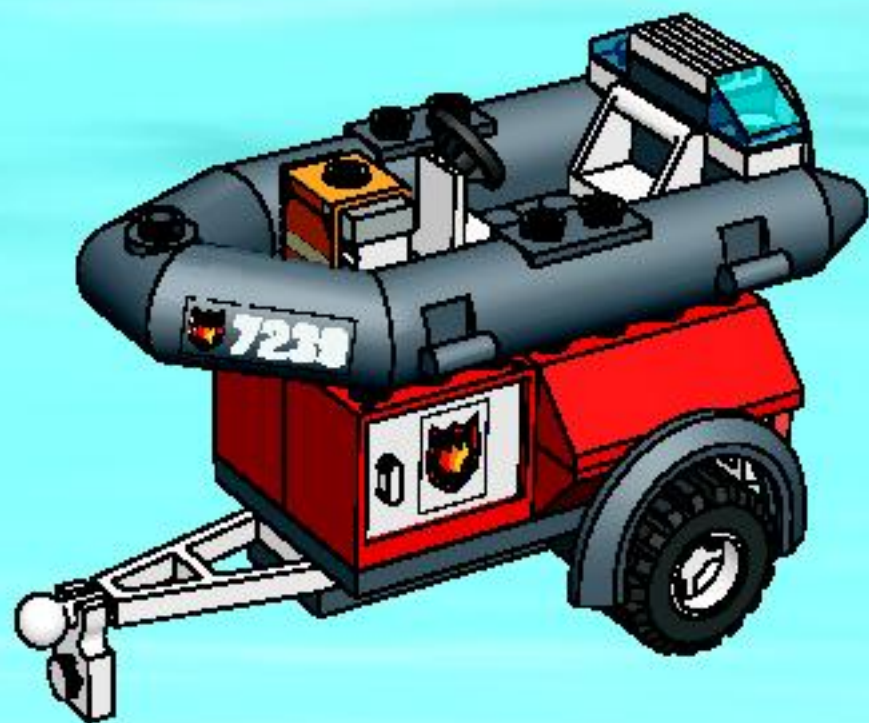

LEGO CITY

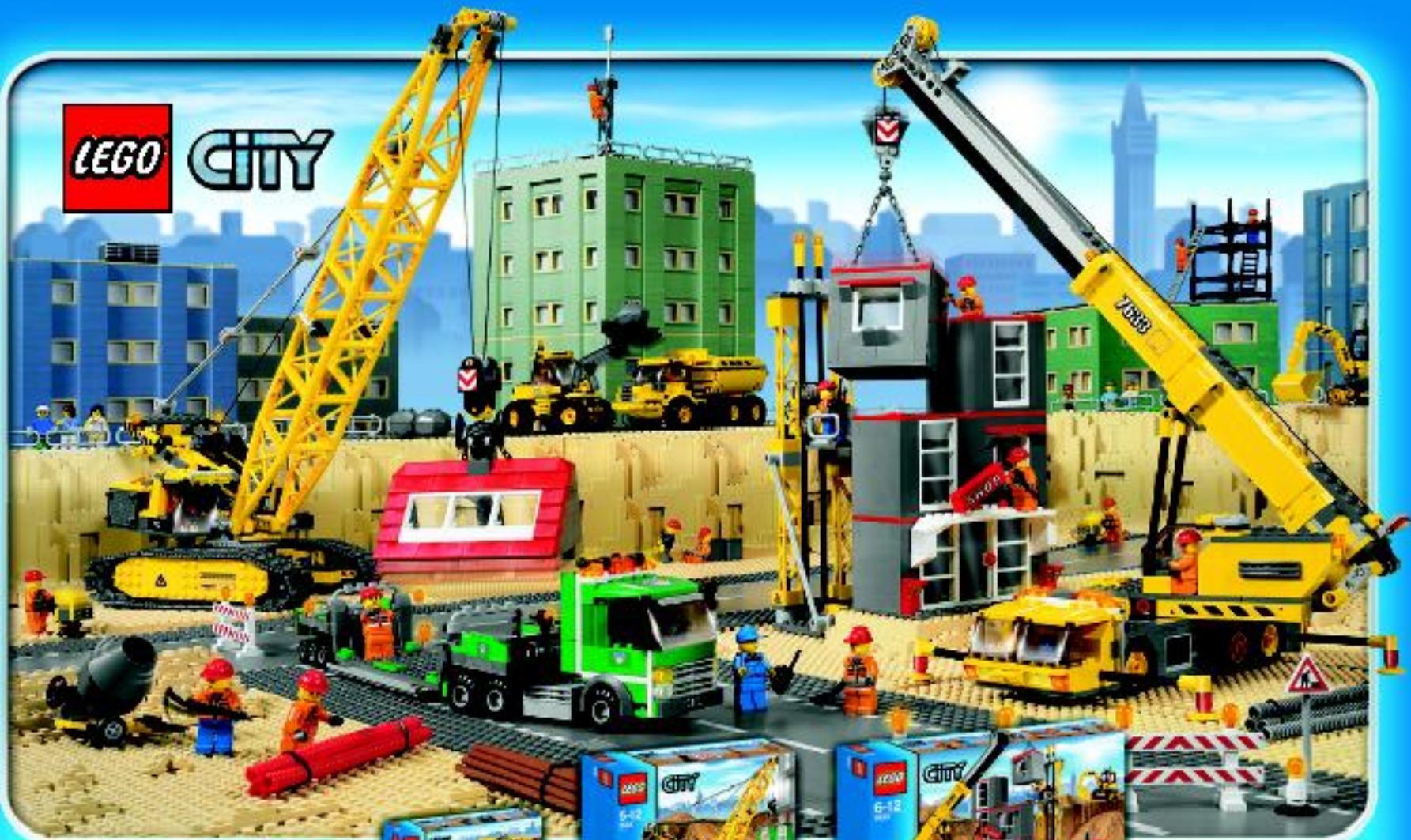

7630



7631



7632



7633



6120



6184



6177

6182



www.LEGO.com





ADVENTURES



FIRST LEGO® DVD MOVIE!
SPRING 2010

Erster LEGO® Film auf DVD! Frühling 2010 - Le premier film LEGO® en DVD ! Printemps 2010 - ¡La primera película de LEGO® en DVD!
Primavera 2010 - Primeiro Filme LEGO® em DVD! Primavera 2010 - Az első LEGO® DVD film! 2010 tavasz

LEGO and the LEGO logo are trademarks of The LEGO Group, © 2009 The LEGO Group, © 2009 The LEGO Group, © 2009 The LEGO Group. All Rights Reserved. © 2009 Universal Studios. All Rights Reserved.





WIN!

 www.LEGO.com

Go to www.nielsen.com/LEGO
to fill out a survey for a chance
to win a cool LEGO® Product.
No purchase necessary.
Open to all residents where not prohibited.



www.nielsen.com/LEGO

GEWINNE!

Nimm an der Umfrage auf www.nielsen.com/LEGO teil und hab die Chance ein cooles LEGO® Produkt zu gewinnen!
Die Teilnahme am Gewinnspiel führt zu keinerlei Kaufverpflichtungen. Teilnahme in allen nicht ausgeschlossenen Ländern möglich.

4586969

WIN!

Ga naar www.nielsen.com/LEGO, vul een enquêteformulier in en maak kans op een cool LEGO® product.
Geen aankoopverplichting, iedereen mag deelnemen, uitgezonderd ingezetenden van landen waar een enquêteverbod geldt.

GAGNE!

Visite www.nielsen.com/LEGO pour répondre à un questionnaire et avoir une chance de gagner un produit LEGO® très cool!
Aucune obligation d'achat.
Ouvert à tous les résidents des pays autorisés.

当てよう!

www.nielsen.com/LEGO にアクセスして、アンケートにご記入ください。
当選者にはレゴ製品を差し上げます。
お買い上げの義務はありません。
禁止されていない限り、すべての管轄にご参加いただけます。

LEGO and the LEGO logo are trademarks of the LEGO Group. ©2010 The LEGO Group.
©2010 Lucasfilm Ltd. & TM. All rights reserved. Used under authorization.