



Taj Mahal:

AGRA, INDIA
AGRA, INDE

LEGO

Architecture

Booklet available in English on
Livret disponible en français sur
Folleto disponible en español en

[LEGO.com/service/buildinginstructions](https://www.lego.com/service/buildinginstructions)



Taj Mahal – The History

Located on the southern bank of the river Yamuna in the Indian city of Agra, the Taj Mahal is one of the great monuments of the world and a symbol of eternal love. The iconic ivory-white marble mausoleum is finally recreated here in LEGO® Architecture scale.

The Taj Mahal was commissioned in 1632 by the grief-stricken Mughal emperor Shah Jahan (1592–1666) to house the tomb of his beloved third wife, Mumtaz Mahal (1593–1631). Over 20,000 laborers and 1,000 elephants were involved in the ambitious construction, which took 22 years to complete at an estimated cost of 32 million Indian rupees (the equivalent of over US \$1 billion at the time).

L'histoire du Taj Mahal

Situé sur la rive sud de la rivière Yamuna dans la ville indienne d'Agra, le Taj Mahal est l'un des grands monuments du monde et un symbole d'amour éternel. L'emblématique mausolée en marbre blanc ivoire a maintenant été recréé à l'échelle LEGO® Architecture.

Le Taj Mahal a été commandé en 1632 par l'endeuillé empereur moghol Shâh Jahân (1592–1666) pour accueillir la tombe de sa troisième épouse bien-aimée, Mumtaz Mahal (1593–1631). Plus de 20 000 ouvriers et 1 000 éléphants ont participé à cette ambitieuse construction, qui a duré 22 ans et coûté environ 32 millions de roupies indiennes (l'équivalent de plus d'un milliard de dollars américains à l'époque).

La historia del Taj Mahal

Ubicado en la orilla sur del río Yamuna, en la ciudad india de Agra, el Taj Mahal es uno de los grandes monumentos del mundo y un símbolo de amor eterno. El inconfundible mausoleo de mármol blanco marfil llega por fin a tus manos, esta vez a escala LEGO® Architecture.

El Taj Mahal fue encargado en 1632 por el afligido emperador mogol Shah Jahan (1592–1666) para alojar la tumba de la que fuera su amada tercera esposa, Mumtaz Mahal (1593–1631). Más de 20.000 trabajadores y 1000 elefantes participaron en la ambiciosa obra, que duró 22 años y tuvo un costo estimado de 32 millones de rupias indias (el equivalente a más de 1000 millones de dólares estadounidenses en ese momento).

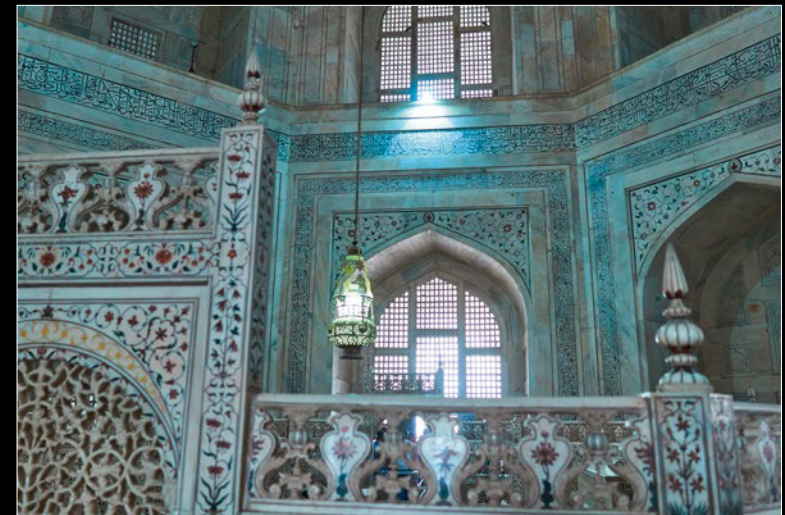

Chamber of Mughal emperor Shah Jahan and Mumtaz Mahal
Chambre de l'empereur moghol Shâh Jahân et de Mumtaz Mahal
Cámara del emperador mogol Shah Jahan y Mumtaz Mahal



Rok Zgalin Kobe, Senior Designer at the LEGO Group.
 Rok Zgalin Kobe, concepteur principal chez le Groupe LEGO.
 Rok Zgalin Kobe, diseñador sénior de The LEGO Group.

The Design Team

As both a trained architect and a LEGO® designer, Rok Zgalin Kobe has always been fascinated by the Taj Mahal and his goal was to recreate the details of this intricate monument. "The story of the Taj Mahal is hopefully mirrored here in LEGO bricks: you lift the roof with the onion dome and chattris, the four domed, columned kiosks, to expose the vaulted ceiling of the central chamber. Hidden beneath the removable central chamber is the crypt holding the tombs with the bodies of Mumtaz Mahal and Shah Jahan."

L'équipe de conception

En tant qu'architecte de formation et concepteur LEGO®, Rok Zgalin Kobe a toujours été fasciné par le Taj Mahal et son but était de recréer les moindres détails de ce monument complexe. « L'histoire du Taj Mahal est, espérons-le, reflétée ici en briques LEGO : vous soulevez le toit avec le dôme en forme d'oignon et les chhatris, les quatre pavillons à colonnes coiffés d'un dôme, pour exposer le plafond voûté de la chambre centrale. Sous la chambre centrale amovible se trouve la crypte accueillant les tombes qui abritent les corps de Mumtaz Mahal et de Shâh Jahân. »

A golden LEGO® ski pole represents the ornament at the apex of the dome of the Taj Mahal.

Un bâton de ski LEGO® doré représente l'ornement au sommet du dôme du Taj Mahal.

Un bastón de esquí LEGO® dorado representa el pináculo de la cúpula del Taj Mahal.



The four slender minarets are divided into three parts by balconies created from LEGO gear elements.

Les quatre minces minarets sont divisés en trois parties par des balcons créés à partir d'éléments d'engrenage LEGO.

Los cuatro esbeltos minaretes están divididos en tres secciones mediante balcones creados a partir de engranajes LEGO.



The decorative spires that extend from the edges of the base walls are created using white LEGO ski poles.

Les flèches décoratives qui sortent des bords extérieurs des murs de base sont créées à partir de bâtons de ski LEGO blancs.

Las agujas decorativas que surgen de los bordes de las paredes de la base están recreadas con bastones de esquí LEGO blancos.



El equipo de diseño

Como arquitecto experto y diseñador de LEGO®, a Rok Zgalin Kobe siempre le ha fascinado el Taj Mahal y su objetivo era recrear los detalles del elaborado monumento. "Espero que el modelo refleje con fidelidad la historia del Taj Mahal mediante bricks LEGO: levantas el techo con la cúpula bulbosa y los chhatris (los cuatro quioscos abovedados con columnas) para descubrir la bóveda de la cámara central. Debajo de la cámara central removible se esconde la cripta que contiene las tumbas con los cuerpos de Mumtaz Mahal y Shah Jahan".





LEGO.com/brickseparator

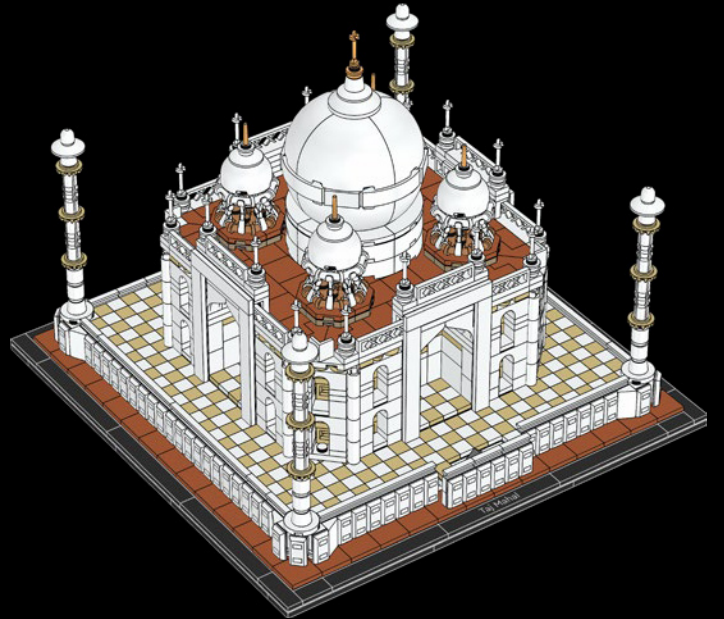
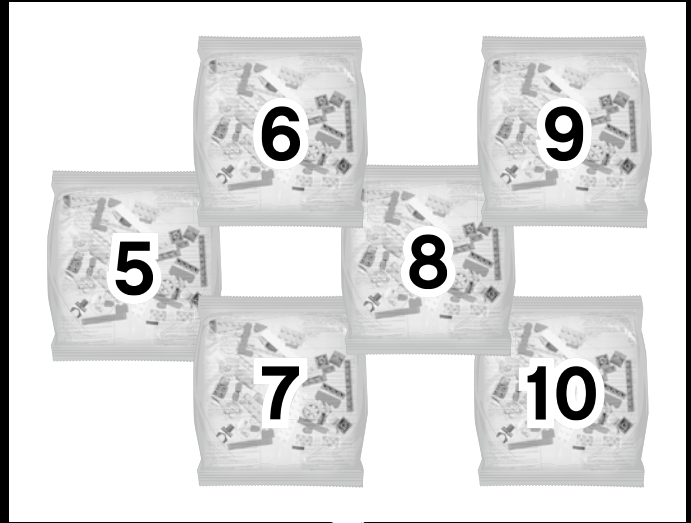
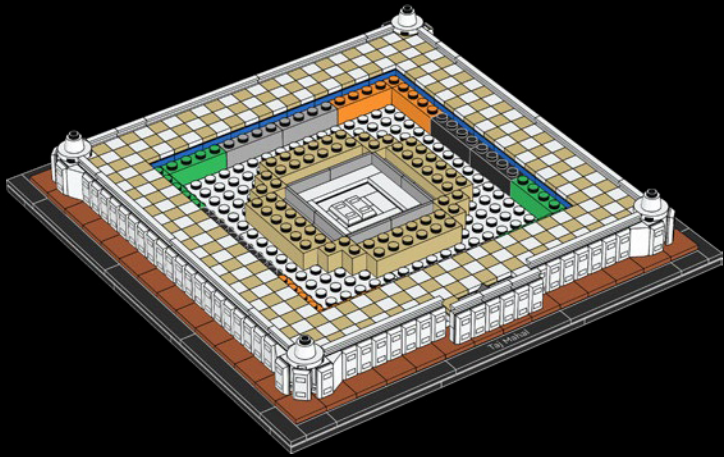

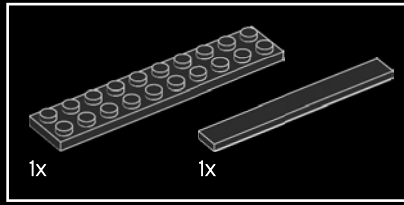
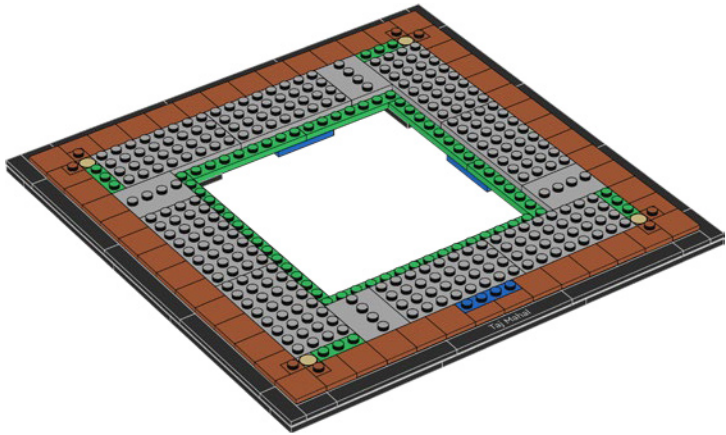
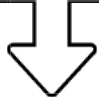

1

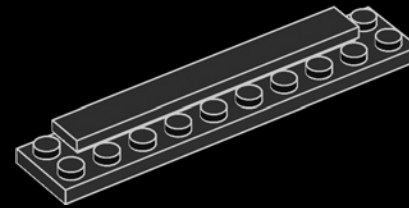

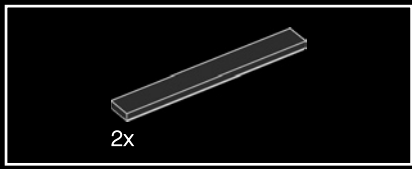

2

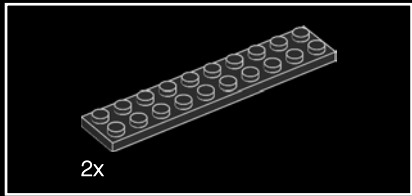
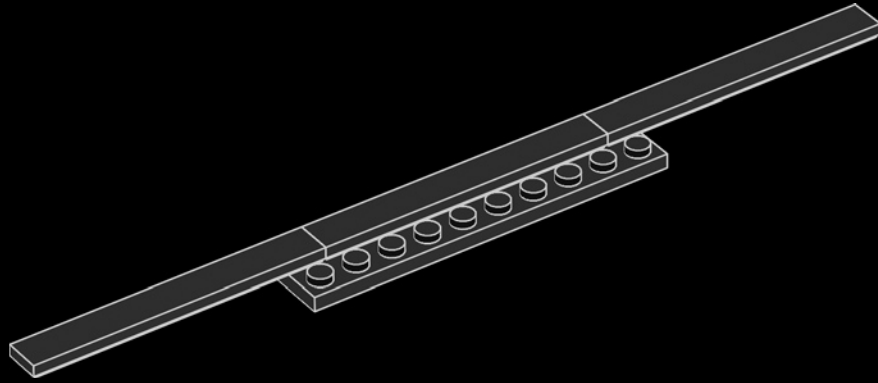

3

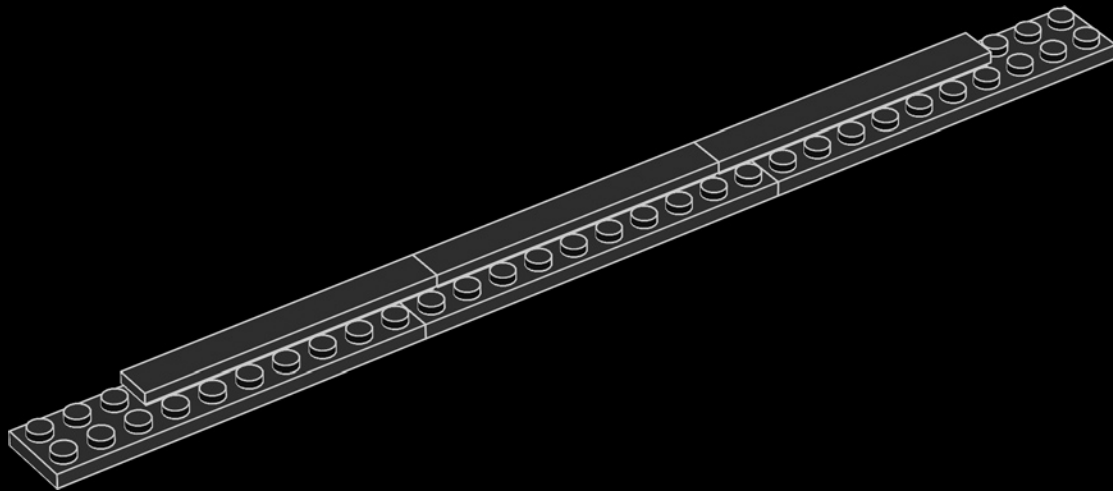

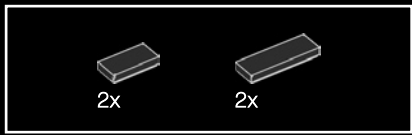

4

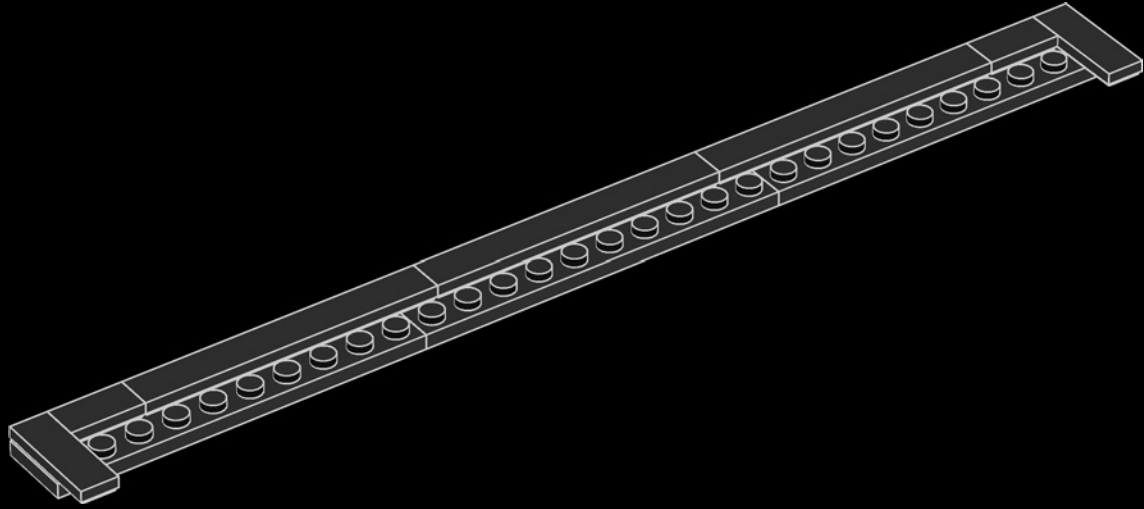

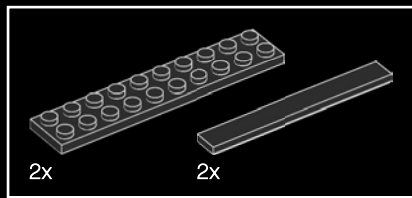

5

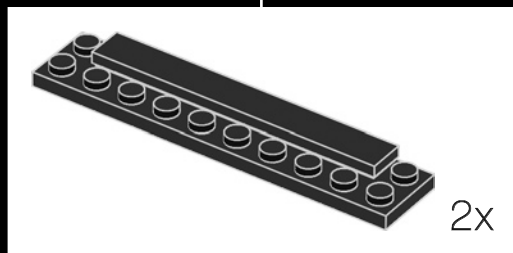
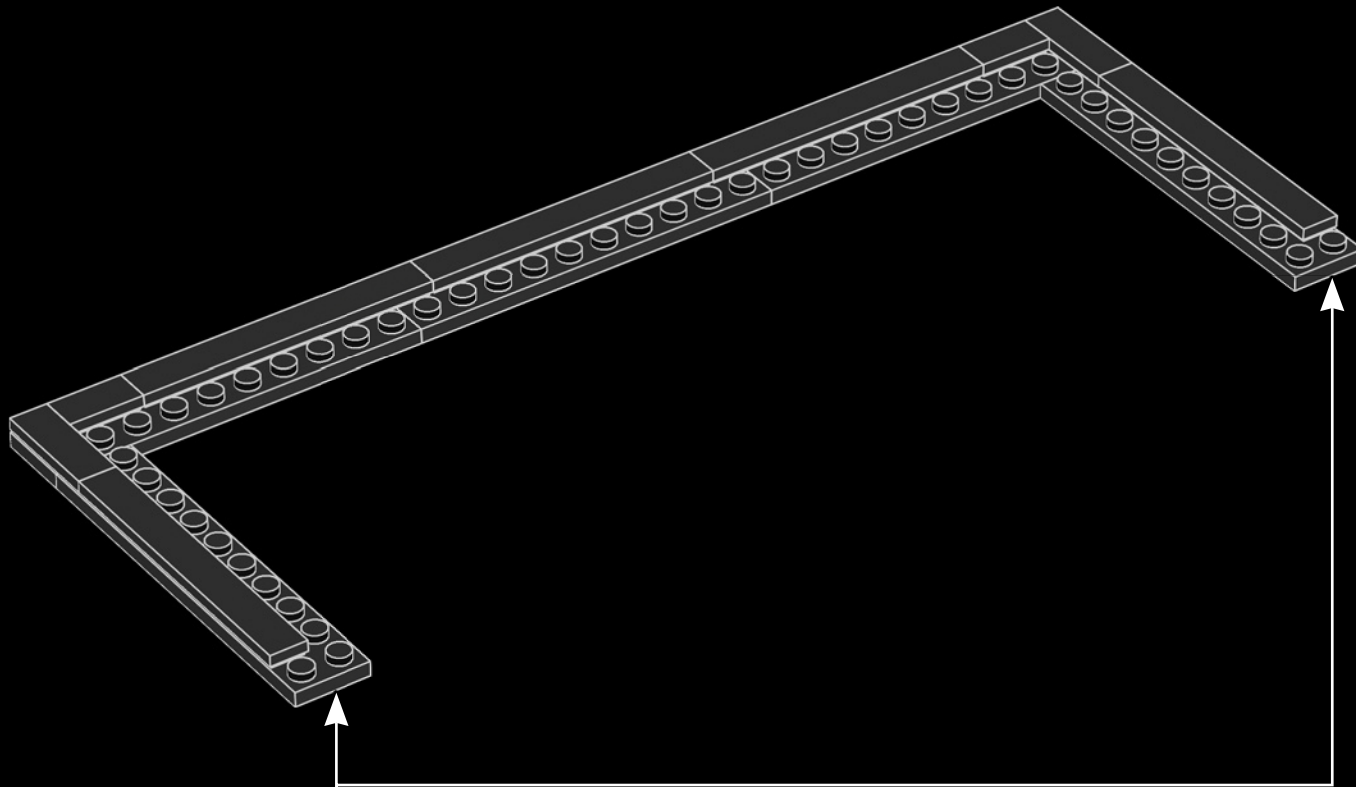

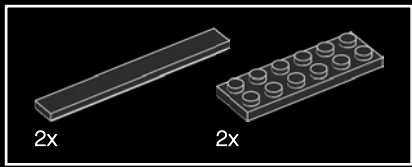

6

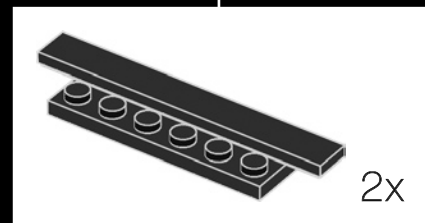
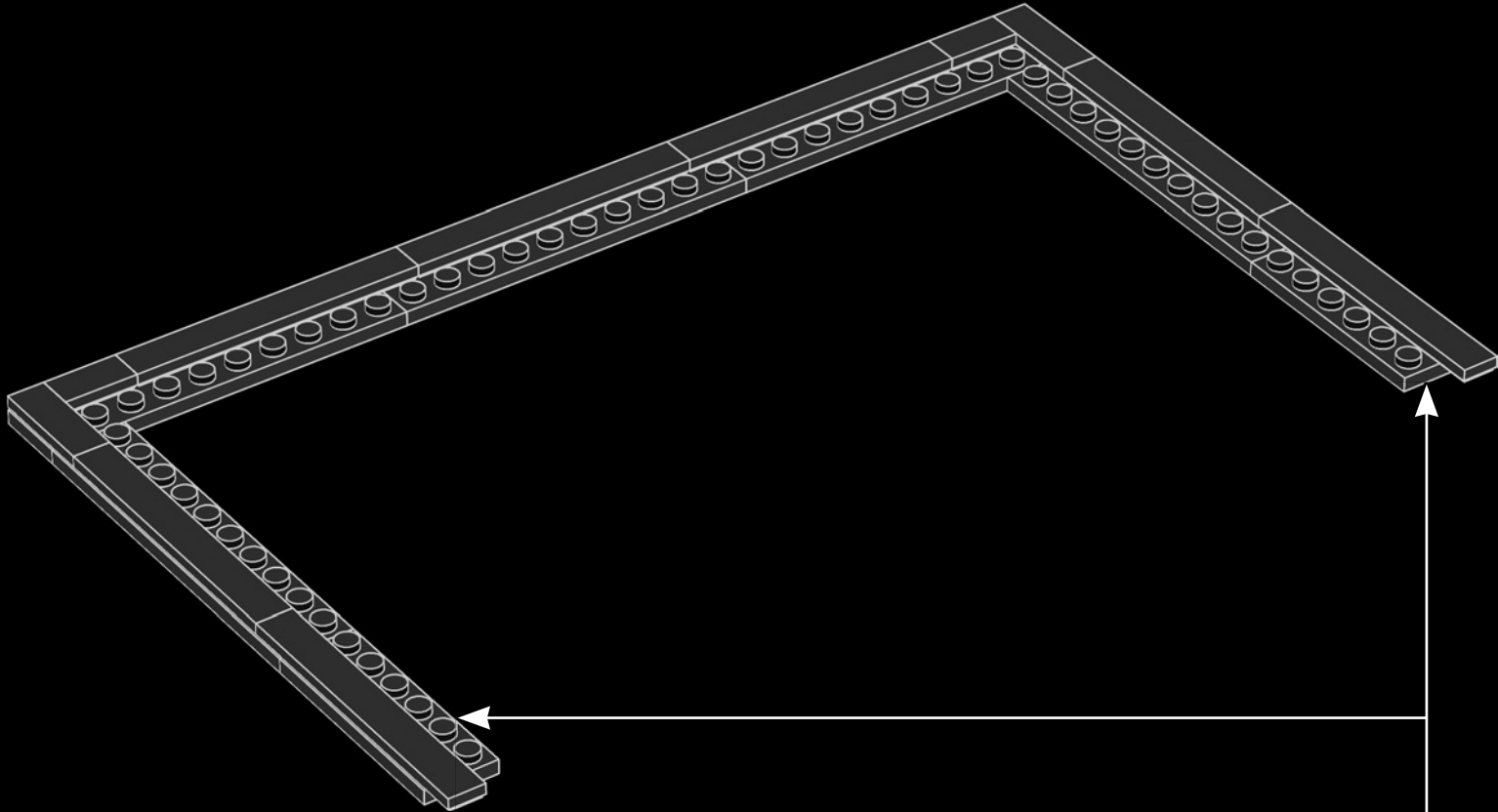

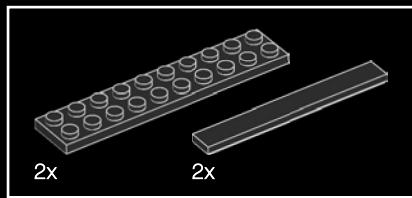

7

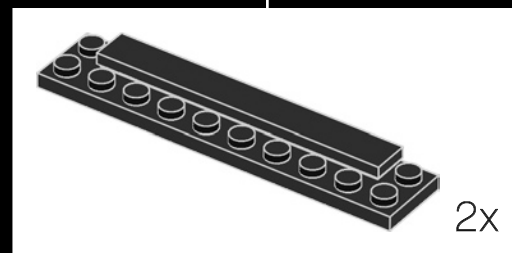
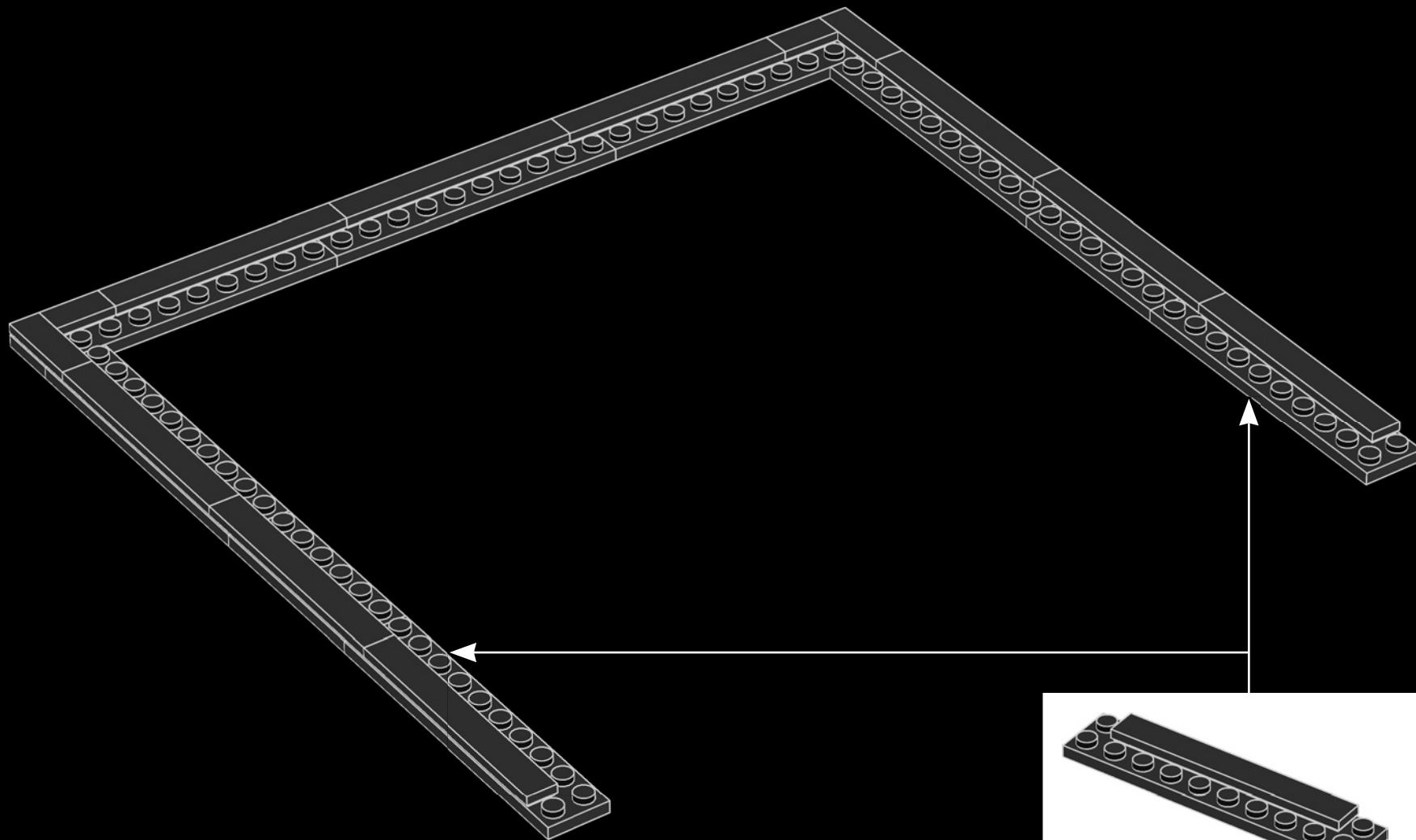

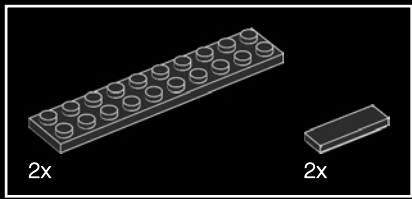

8

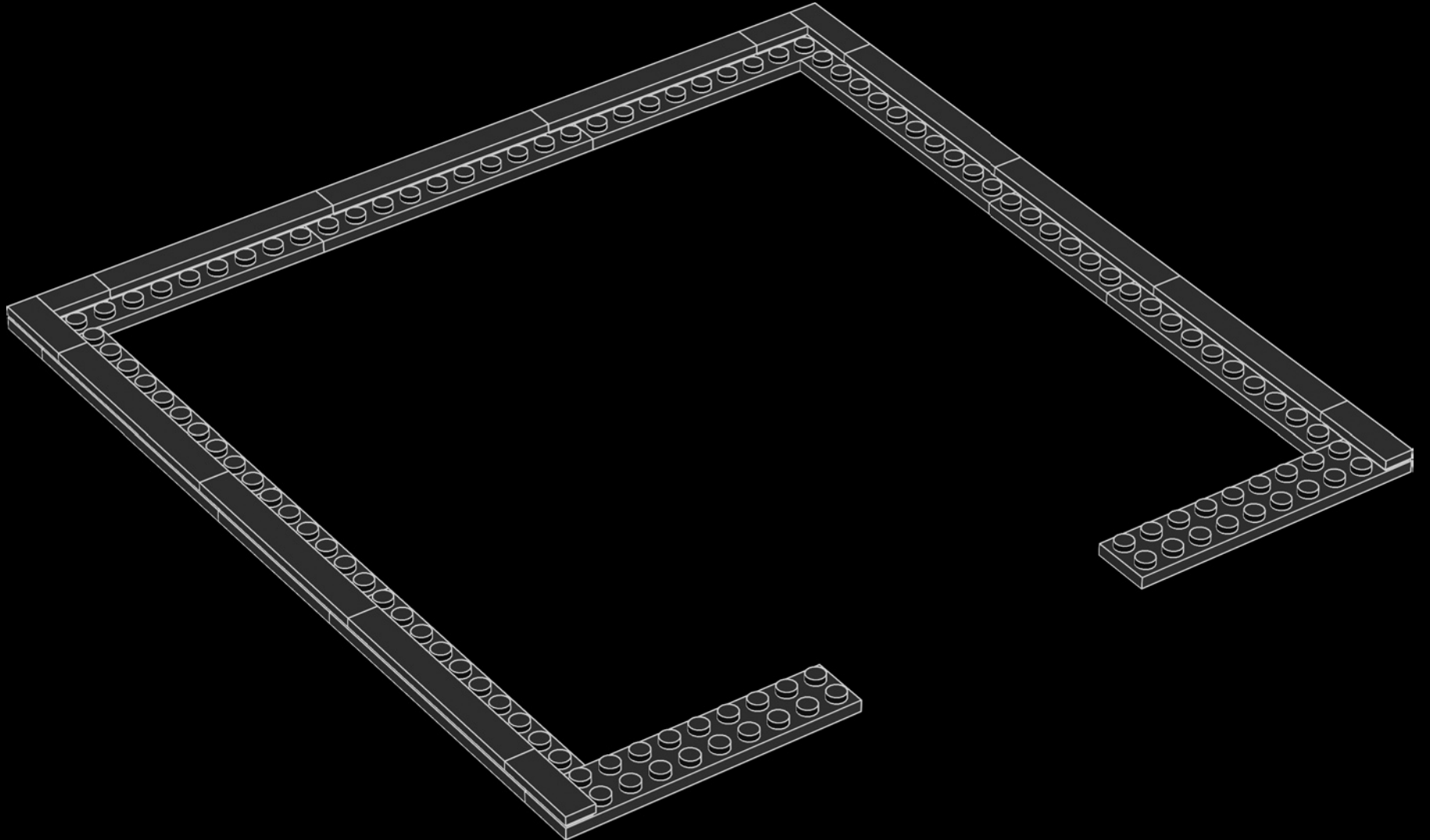

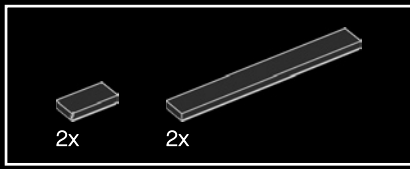

9

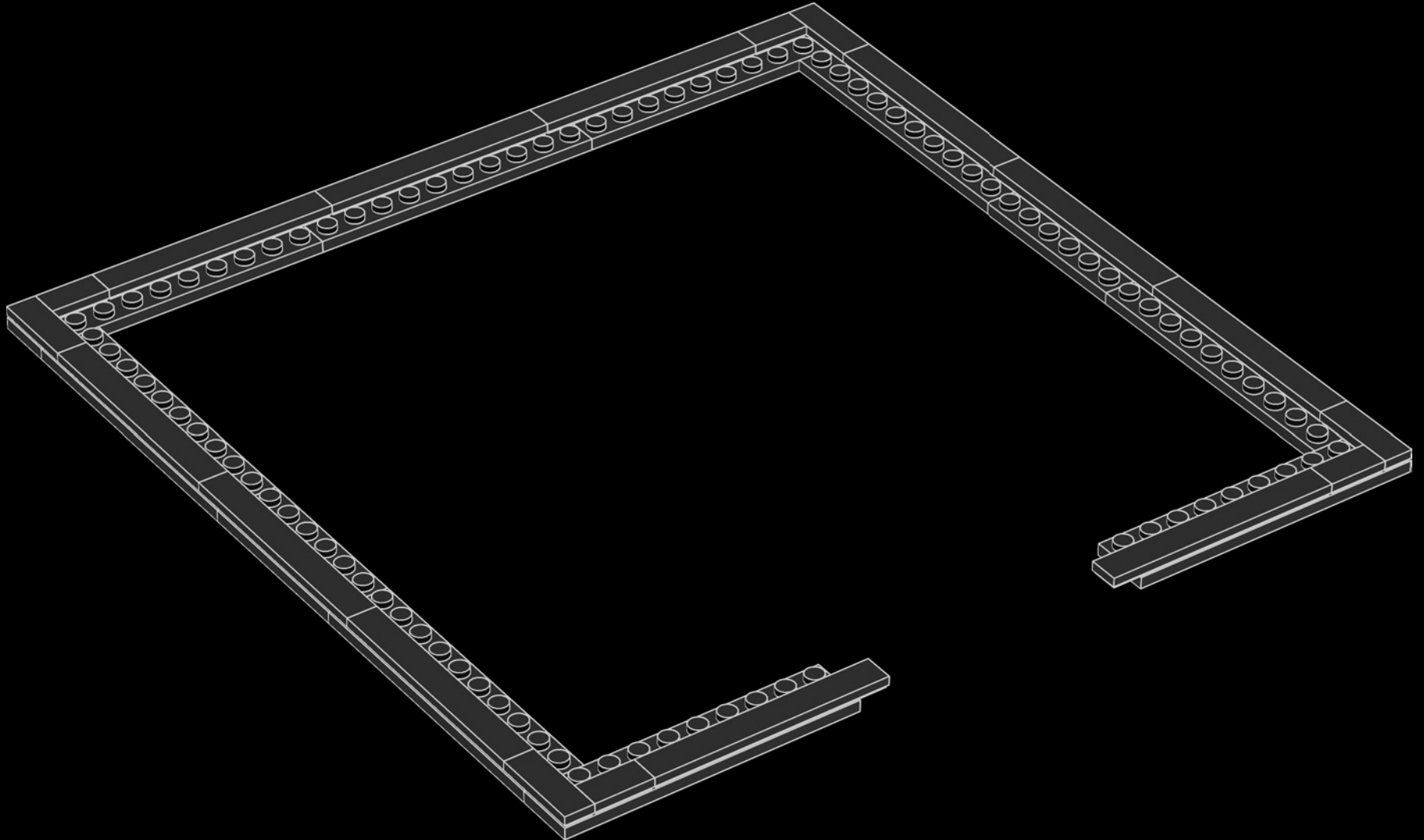

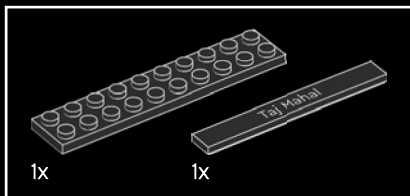

10

During British rule in India, the garden was landscaped to look more like the manicured lawns of England.

Pendant l'Empire britannique des Indes, le jardin a été aménagé pour ressembler davantage aux pelouses soignées de l'Angleterre.

Durante el dominio británico de la India, el jardín se cultivó para que se asemejara a los cuidados parques de Inglaterra.

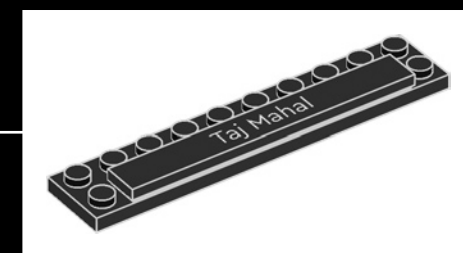
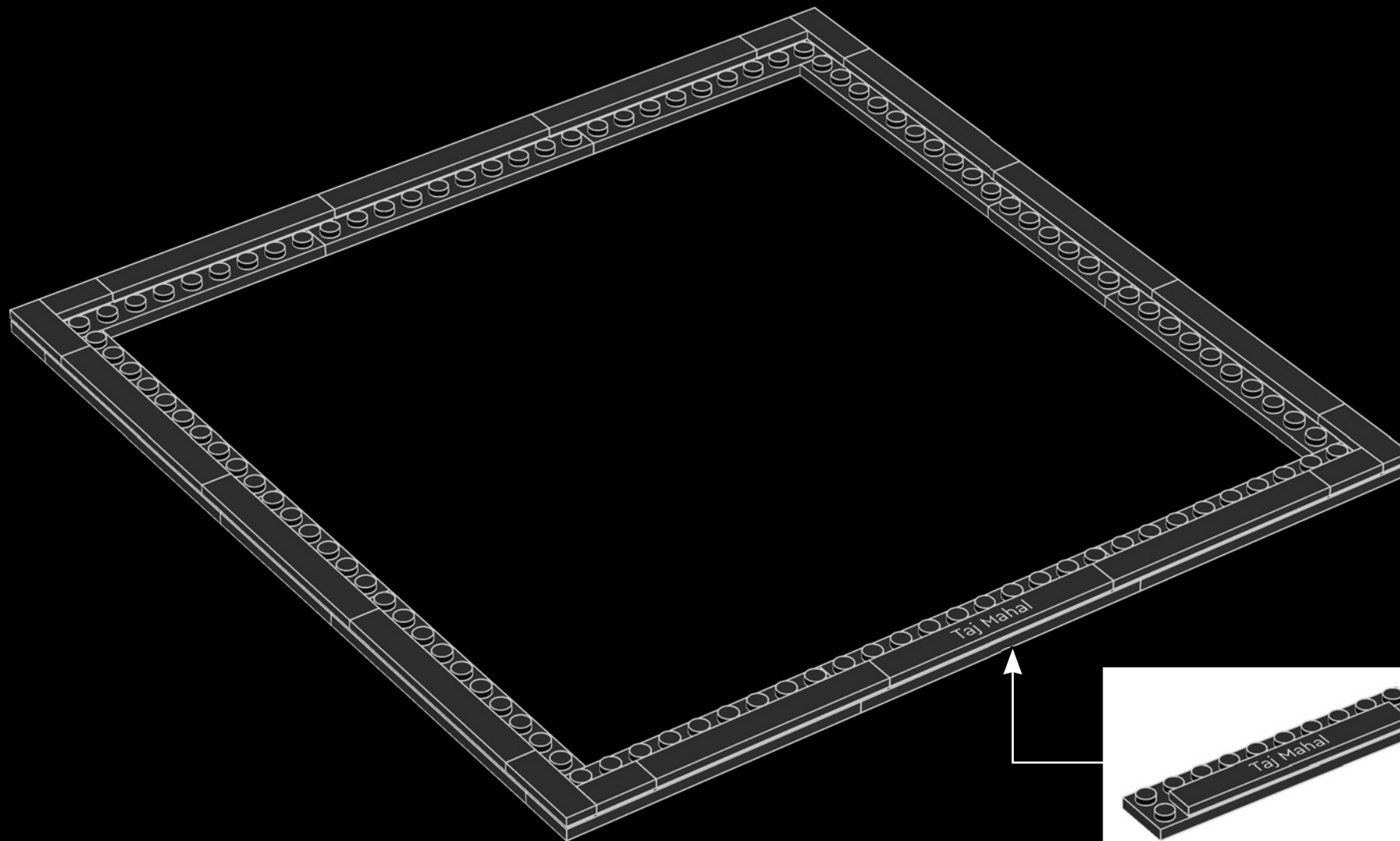
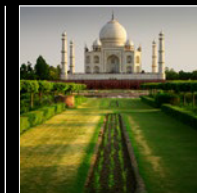

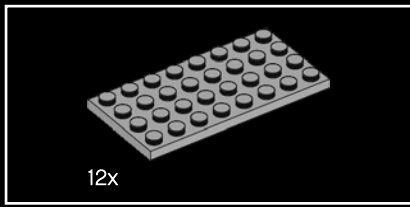

11

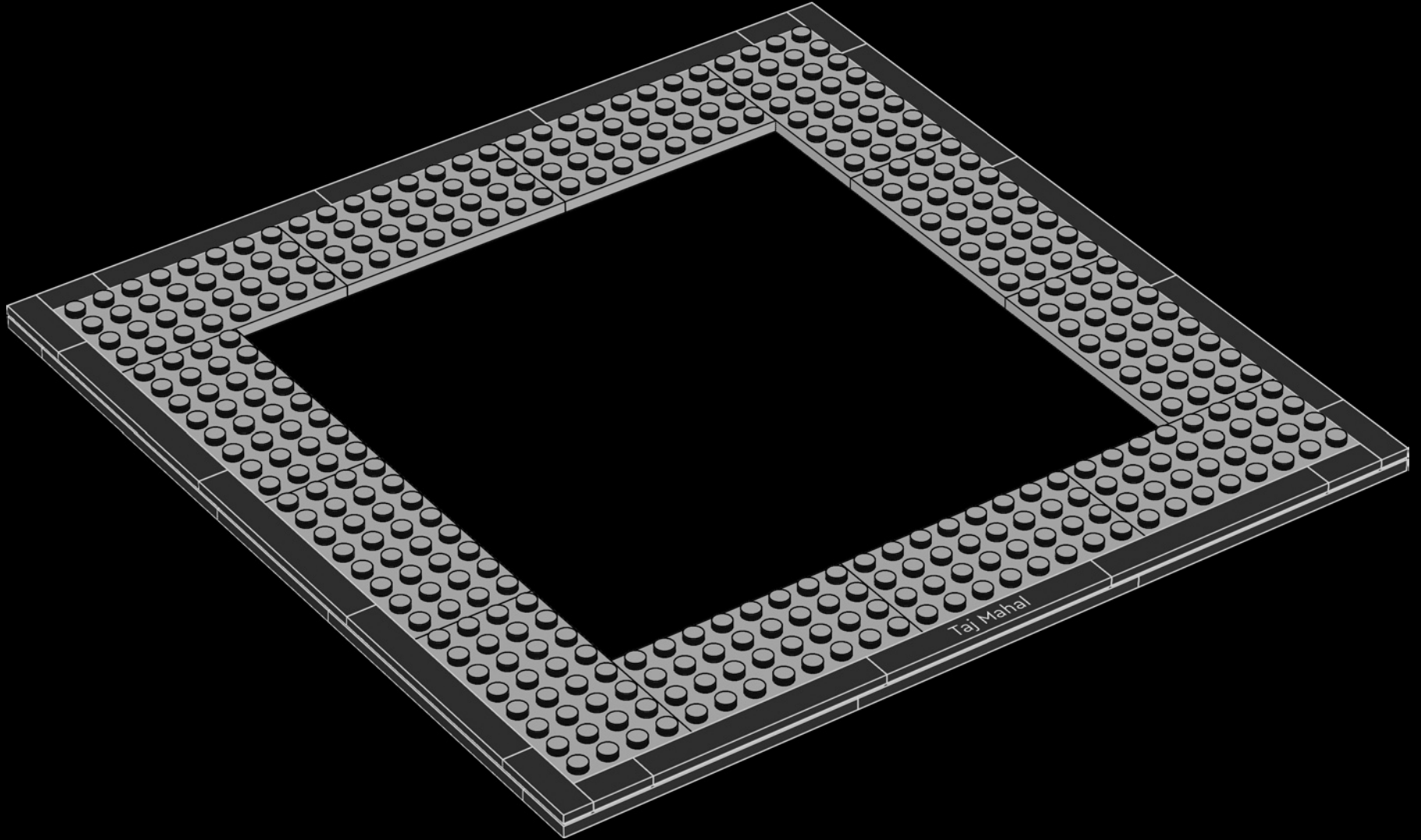

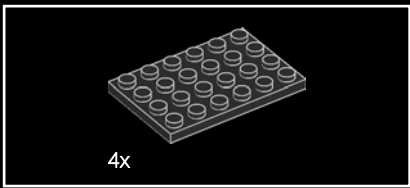

12

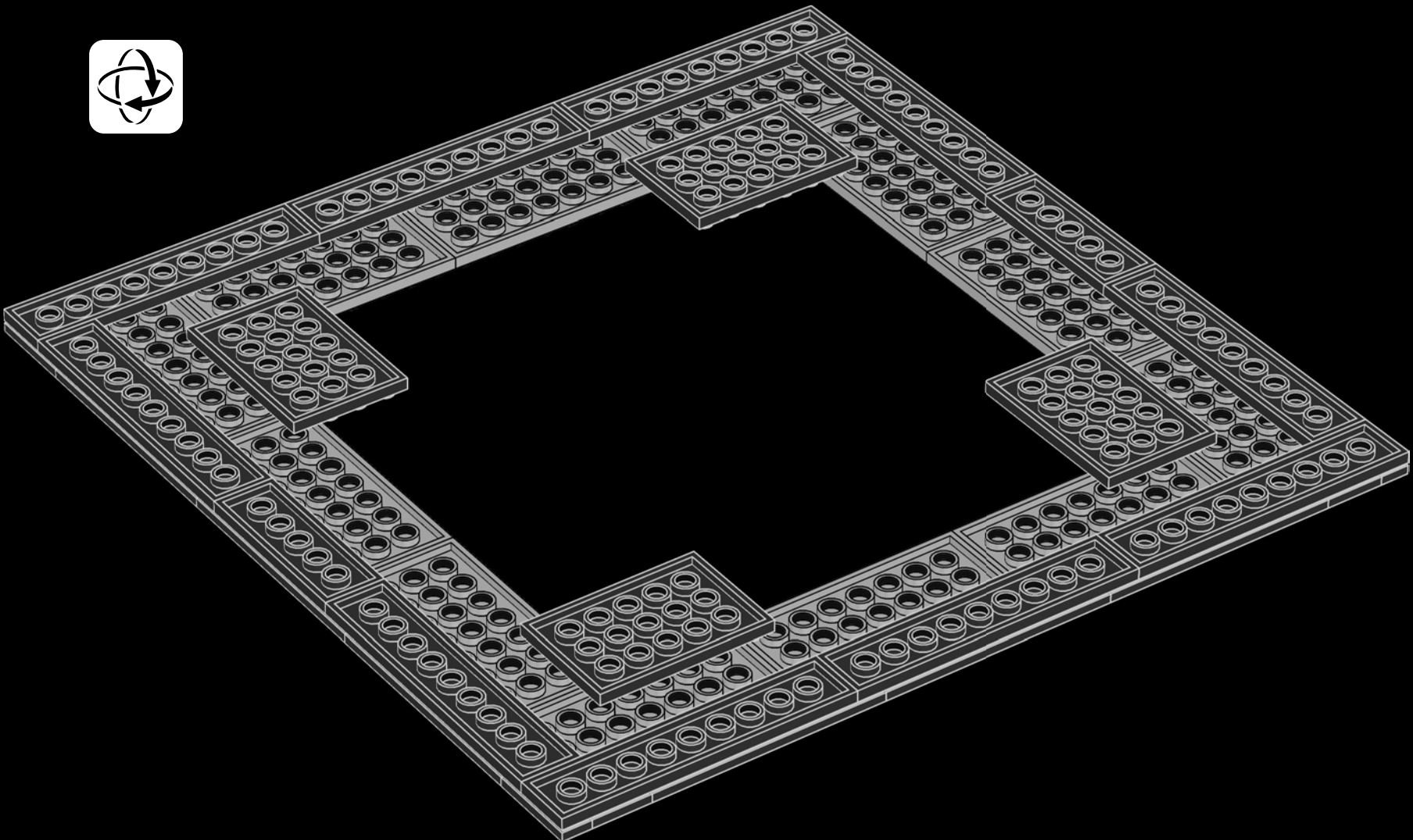

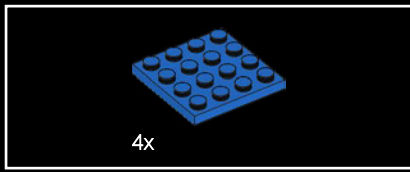

13

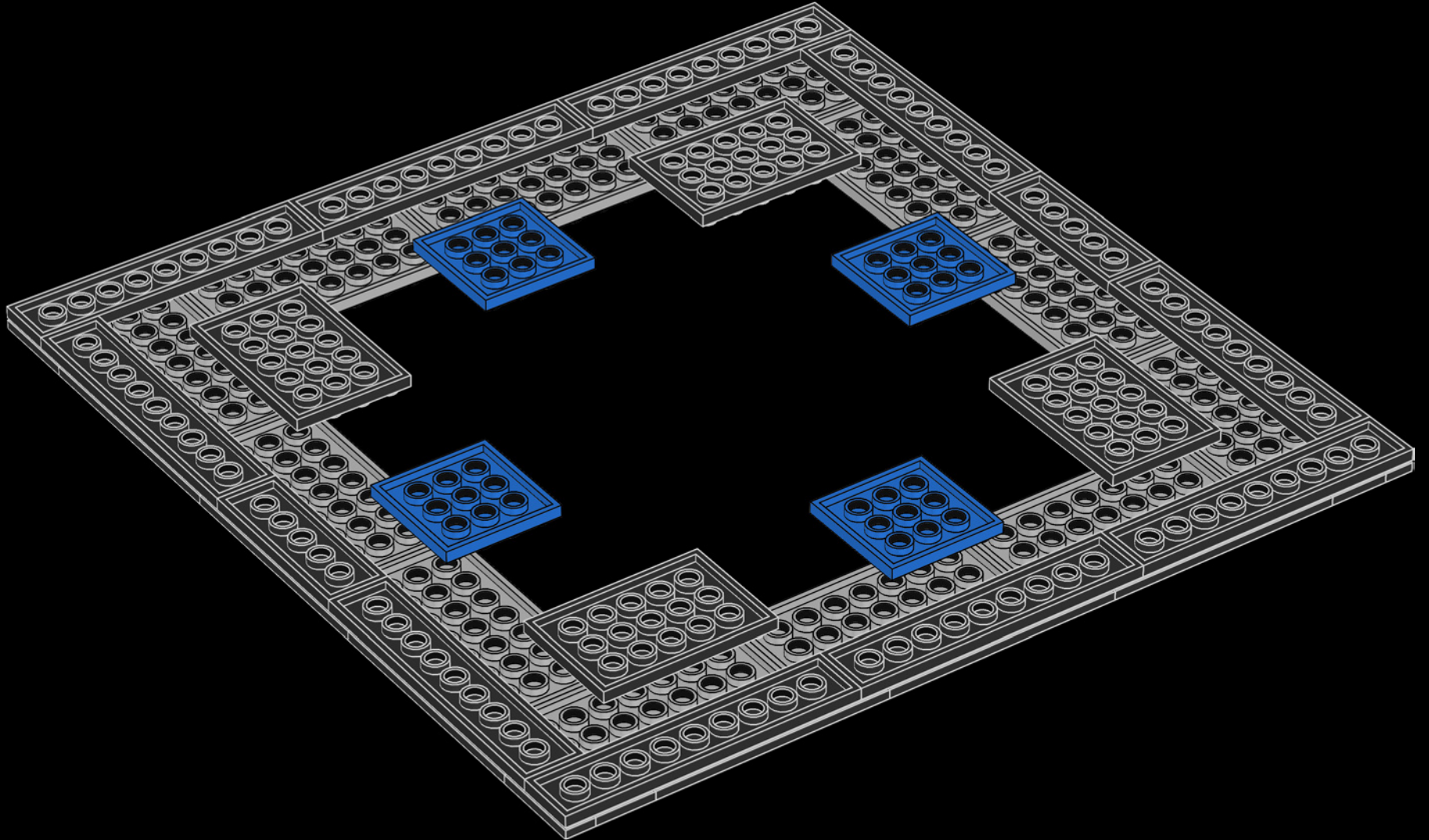

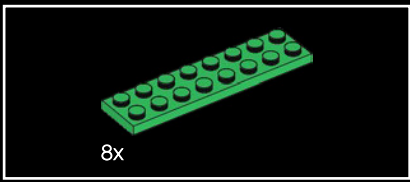

14

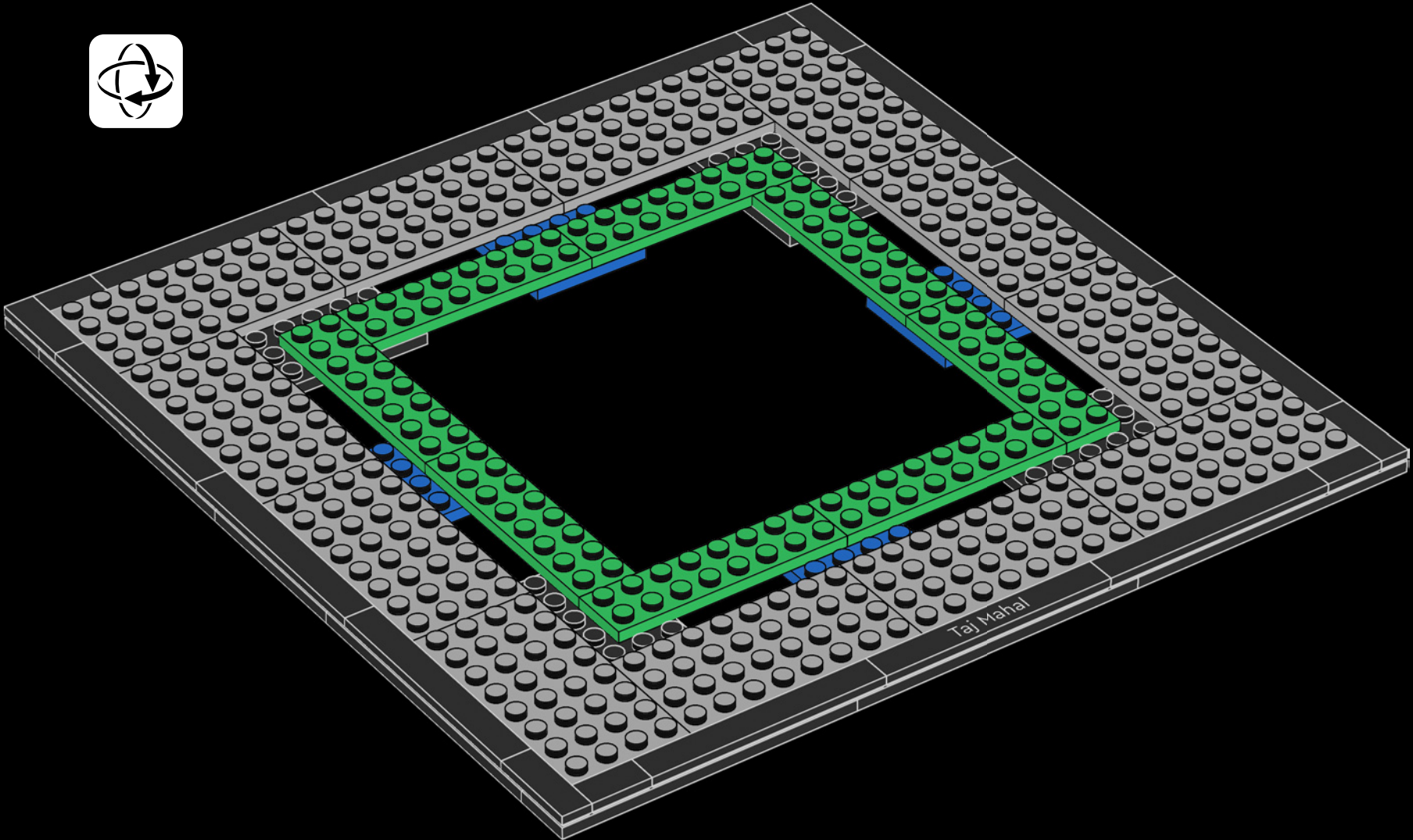

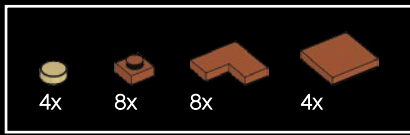

15

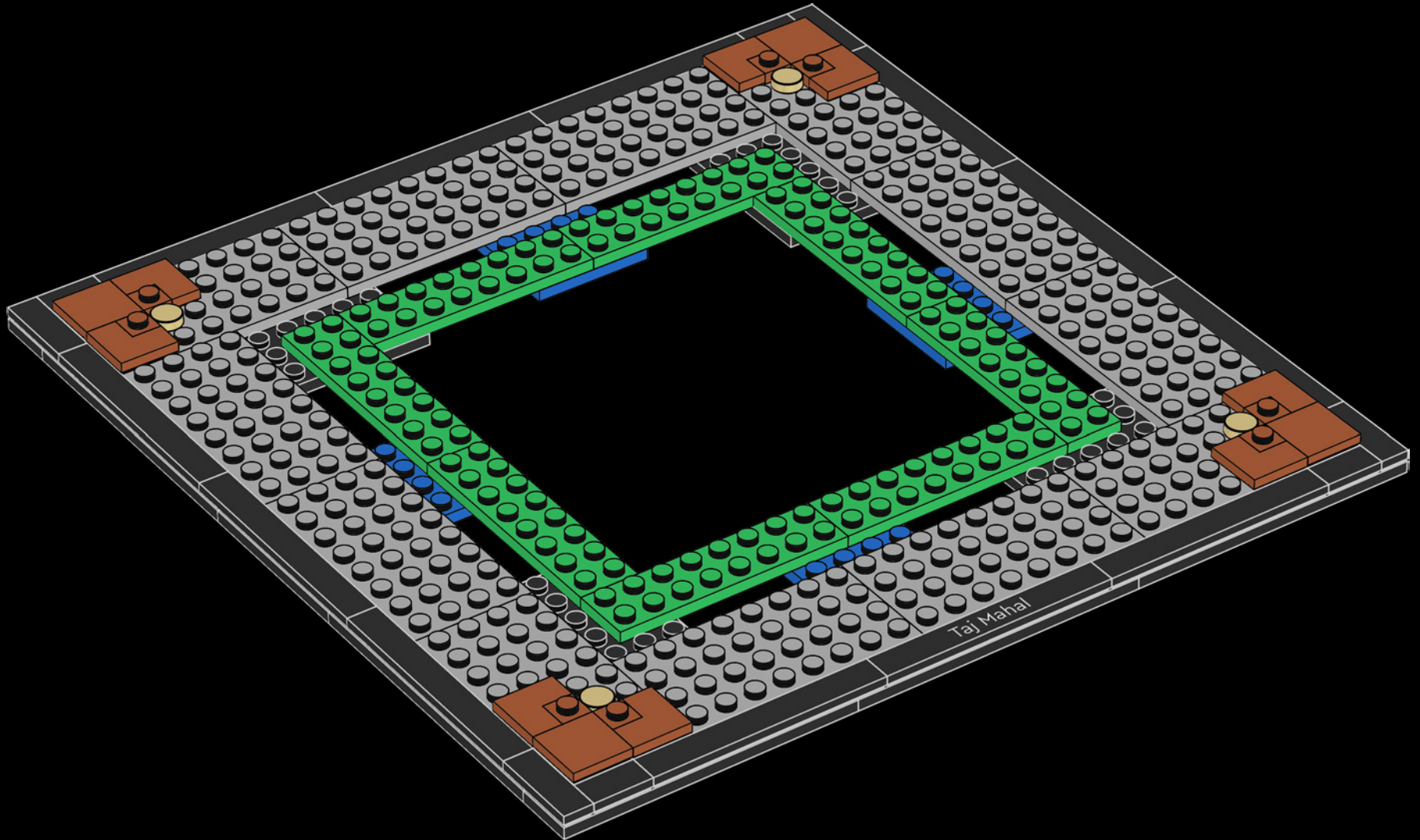

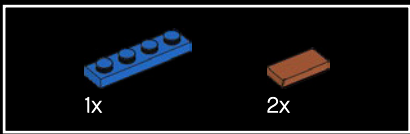

16

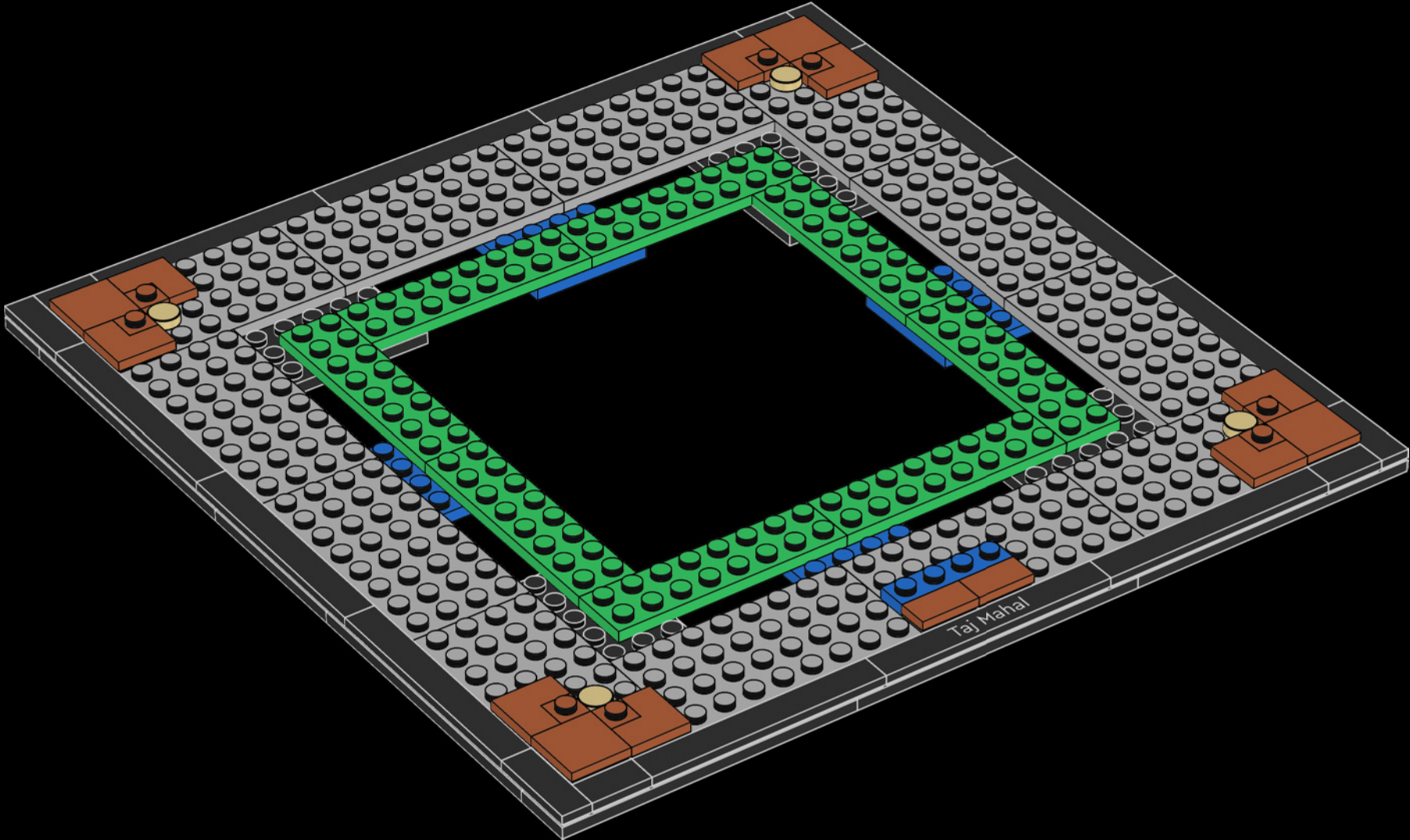



17

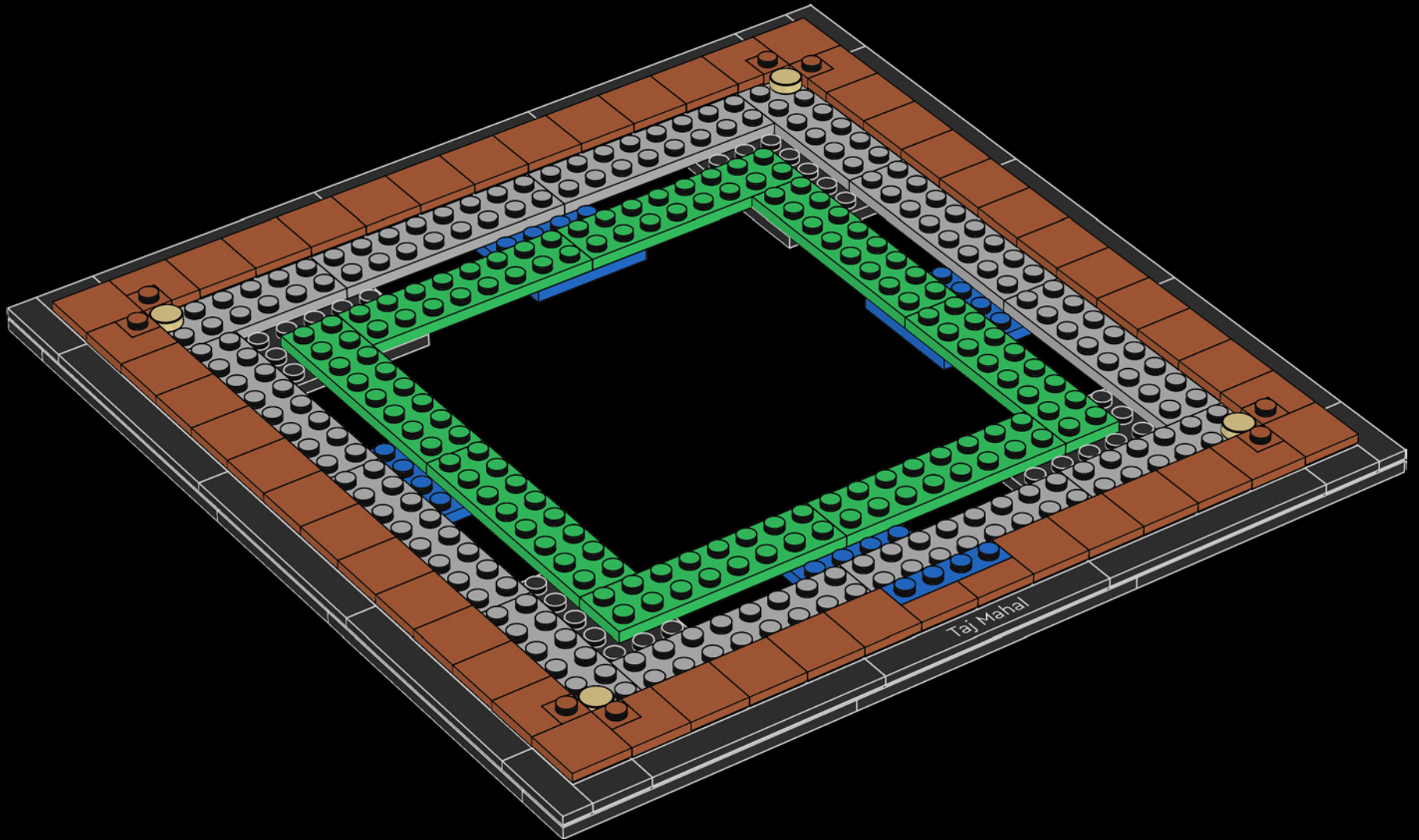

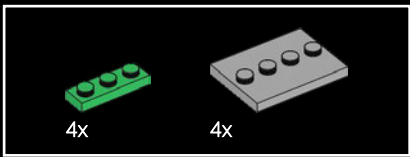

18

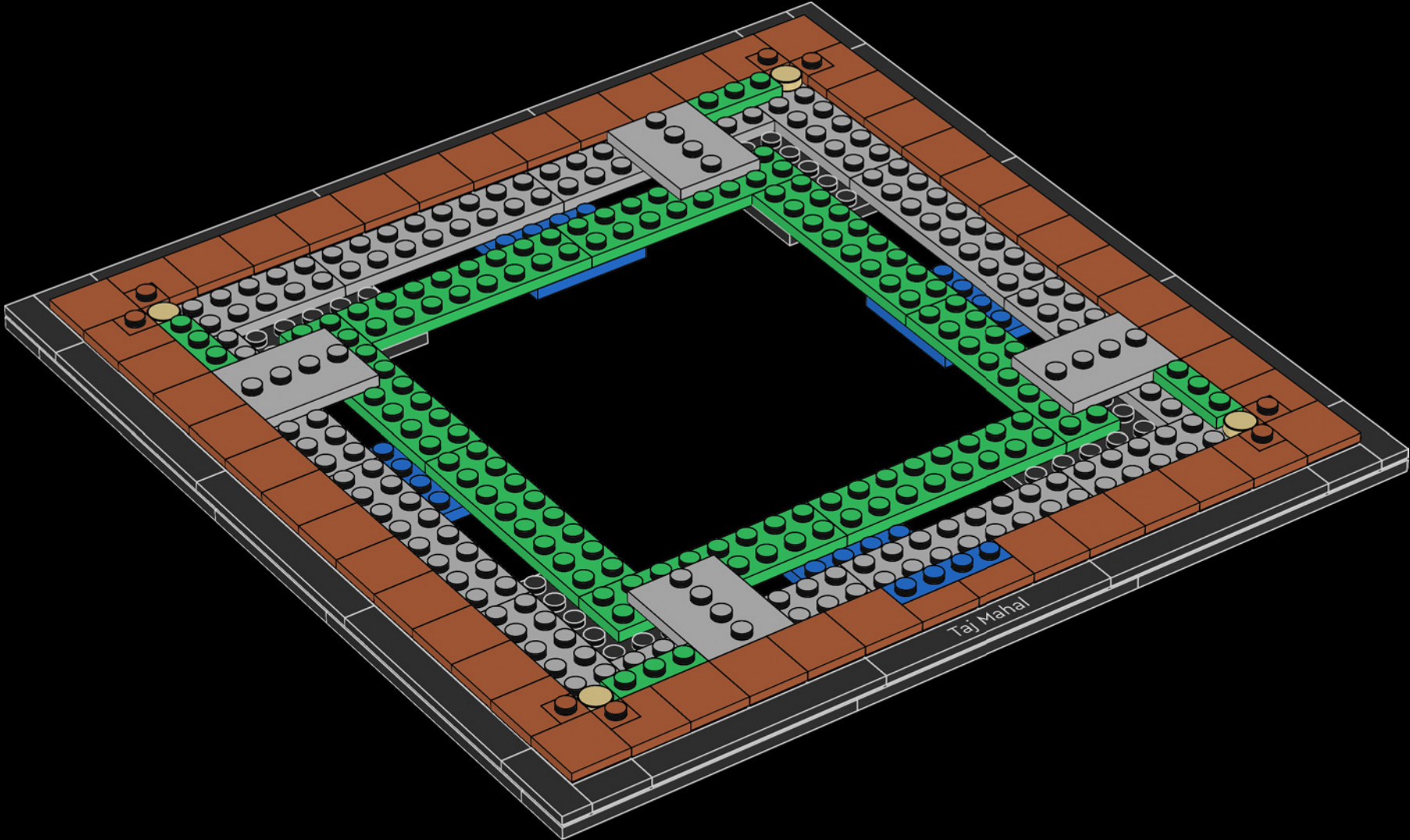

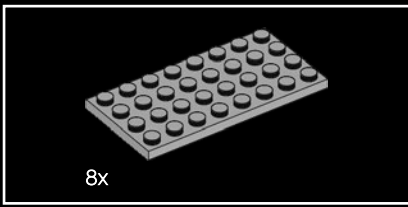

19

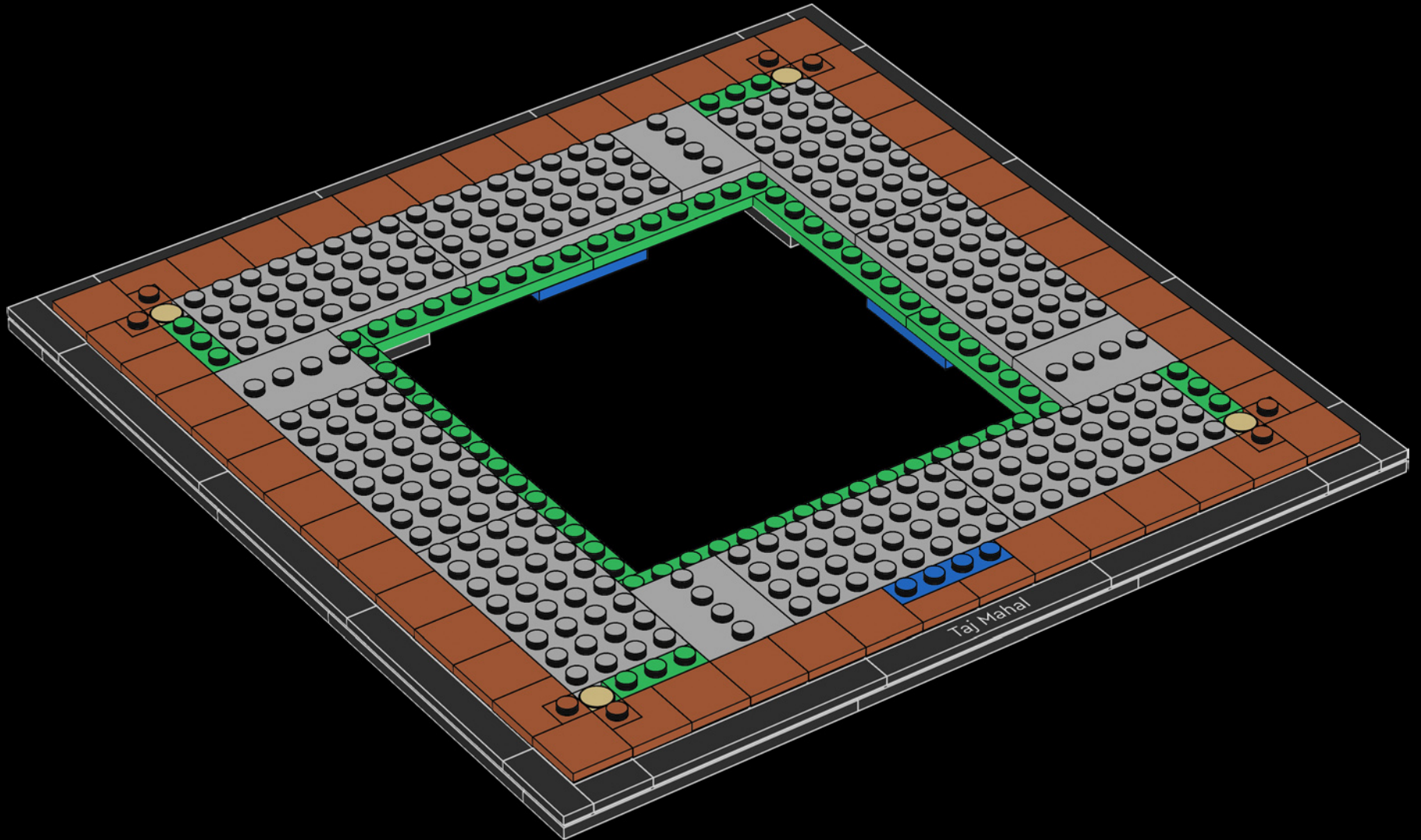

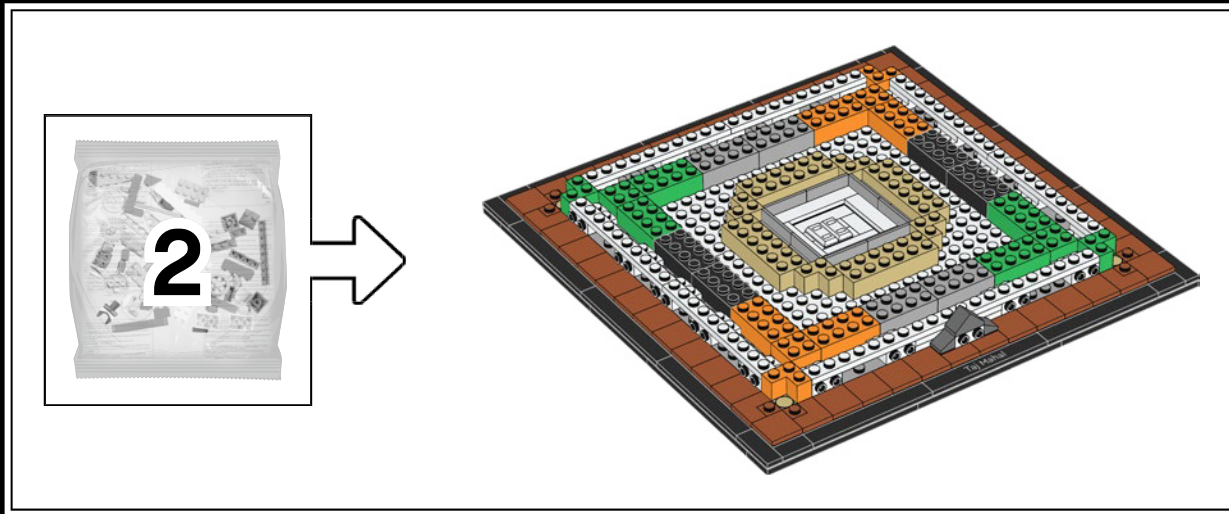

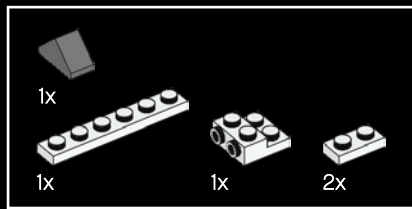

20

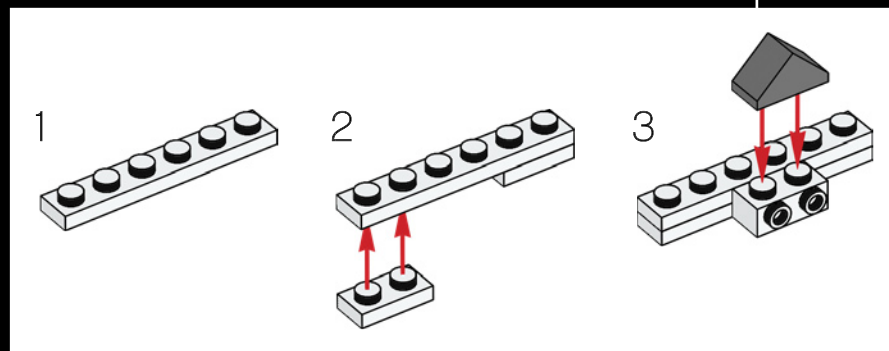
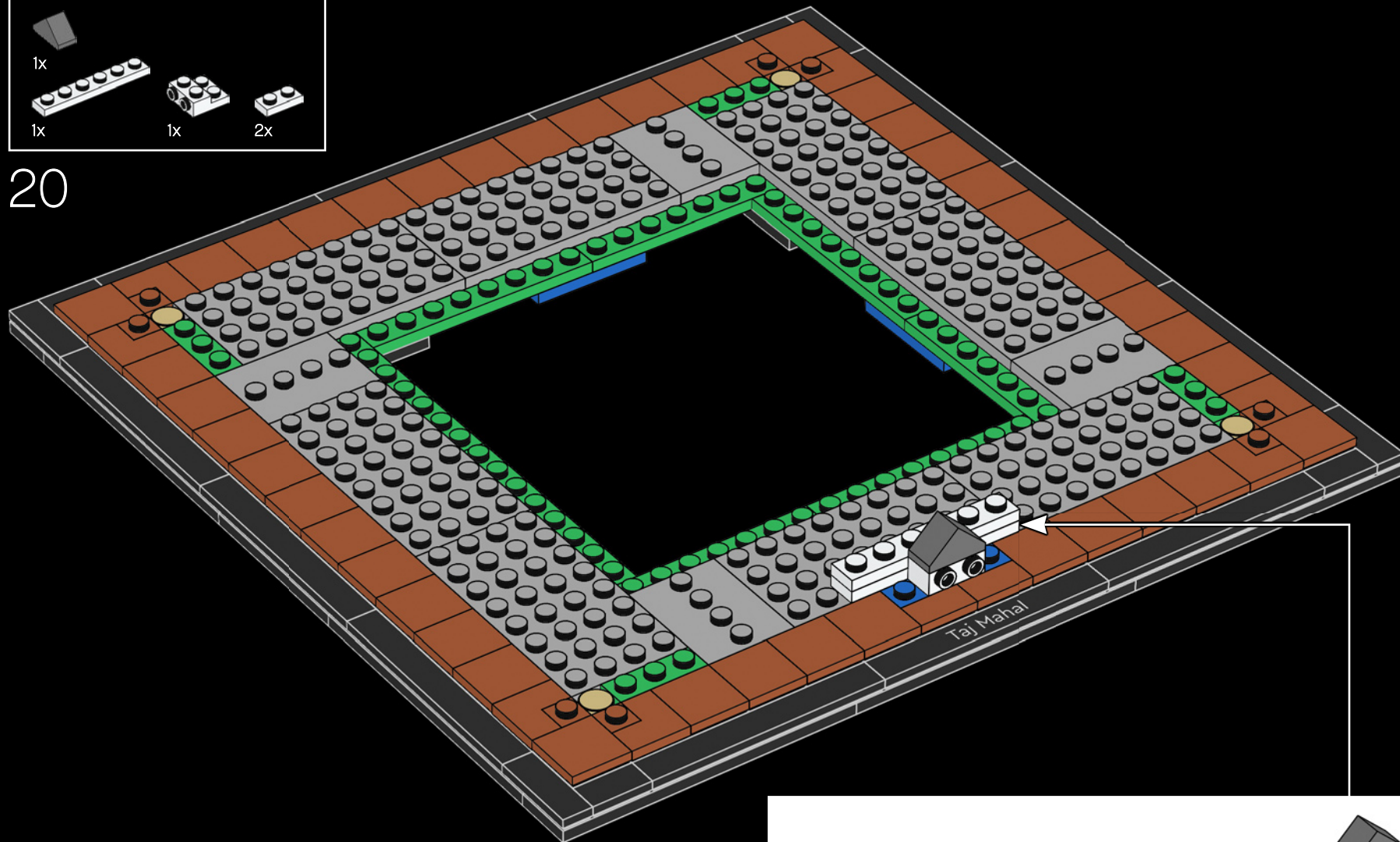

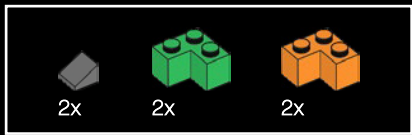

21

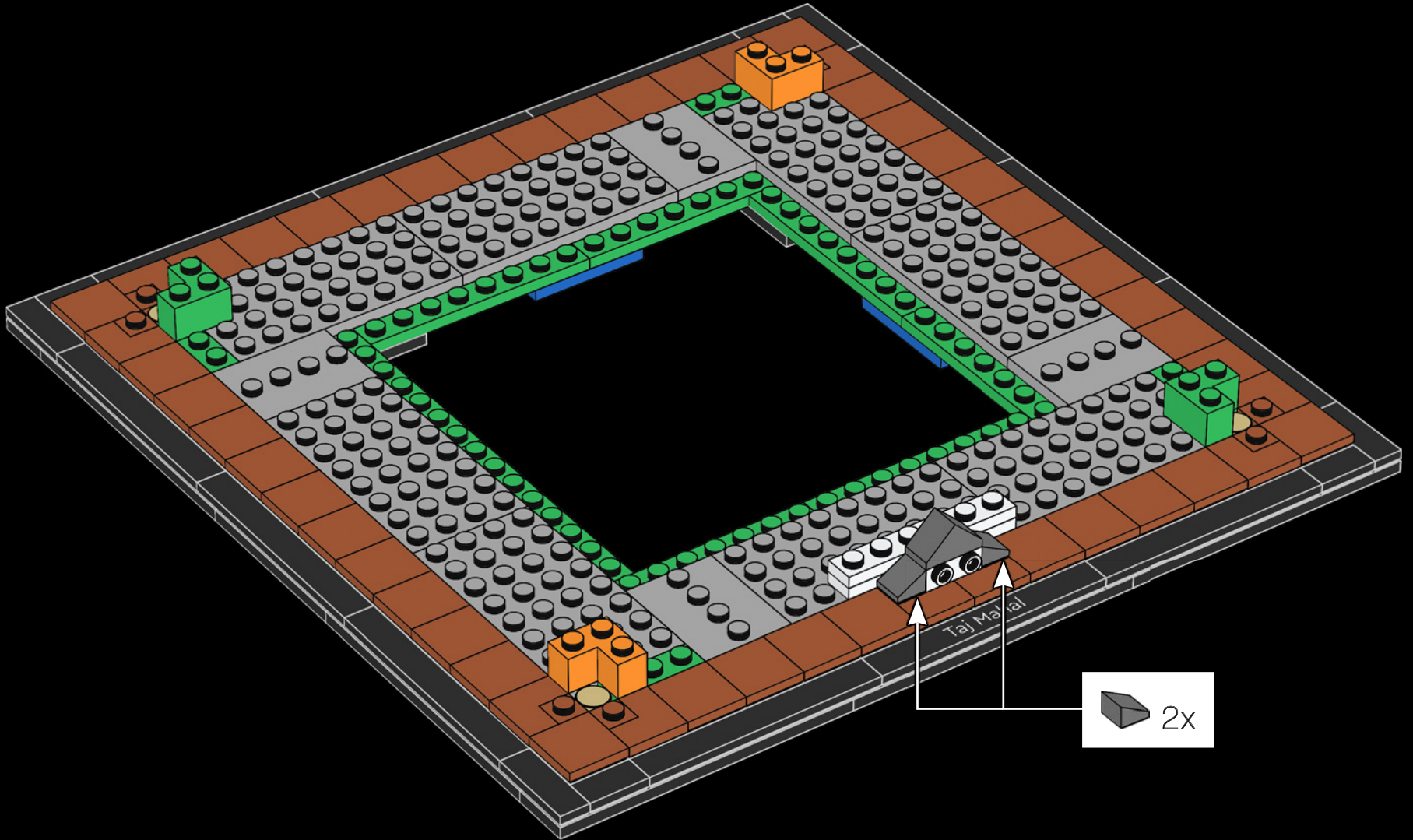

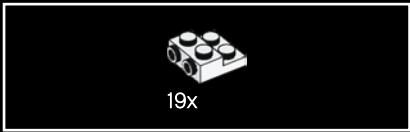

22

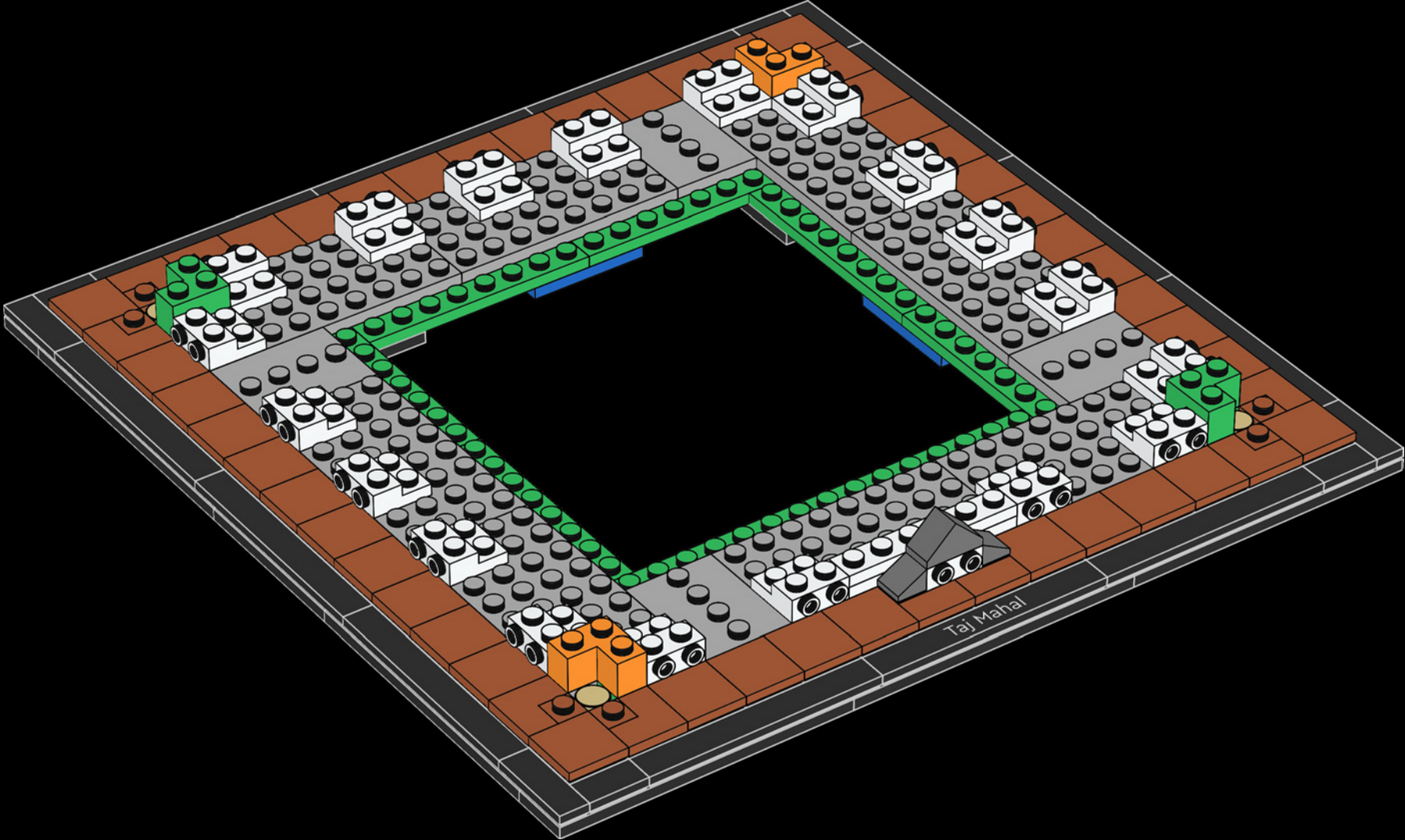

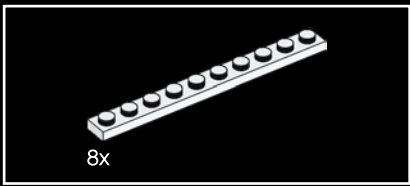

23

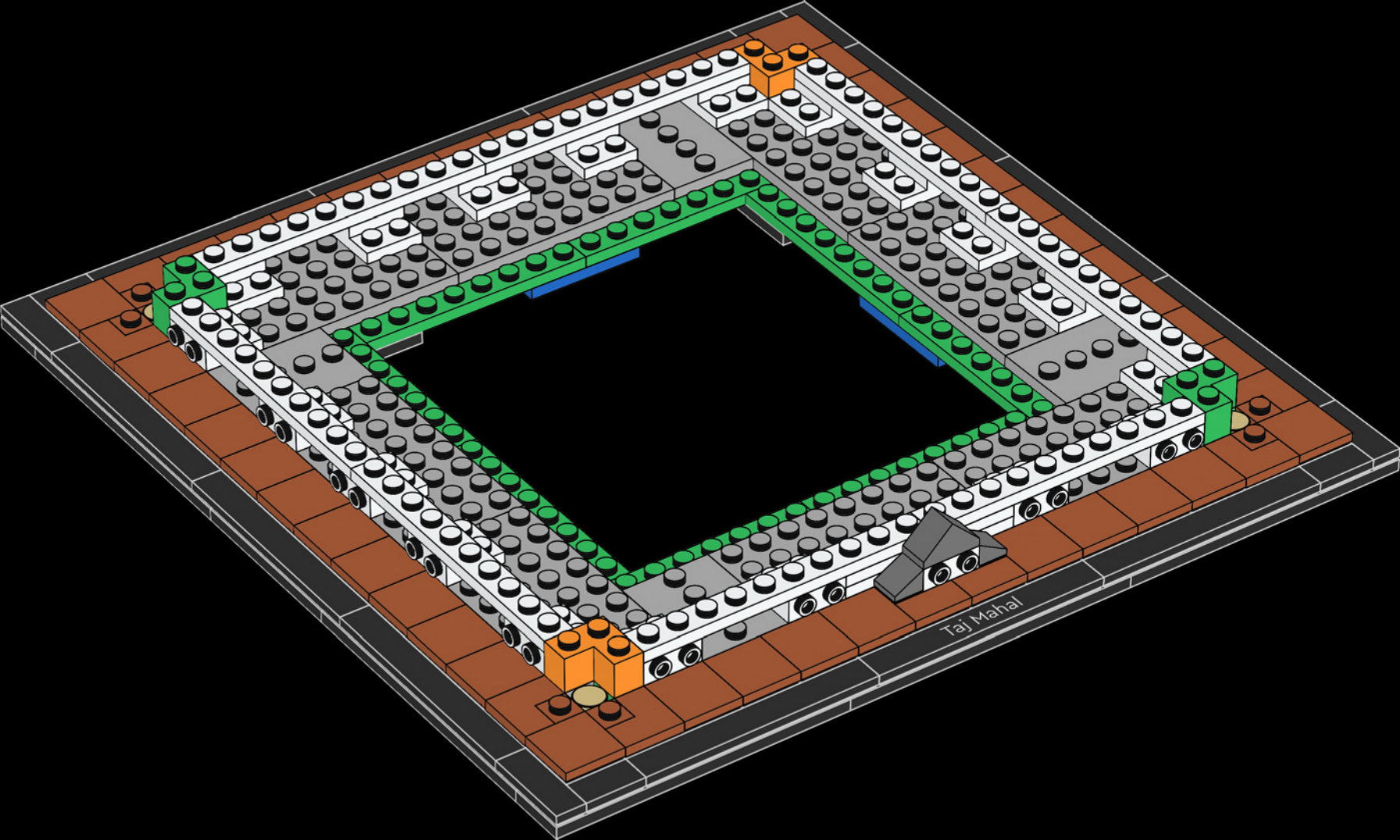

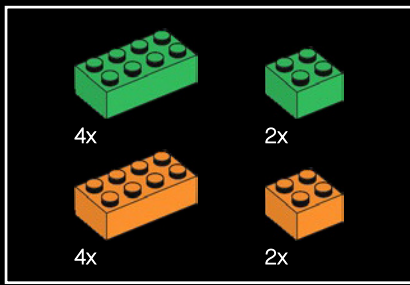

24

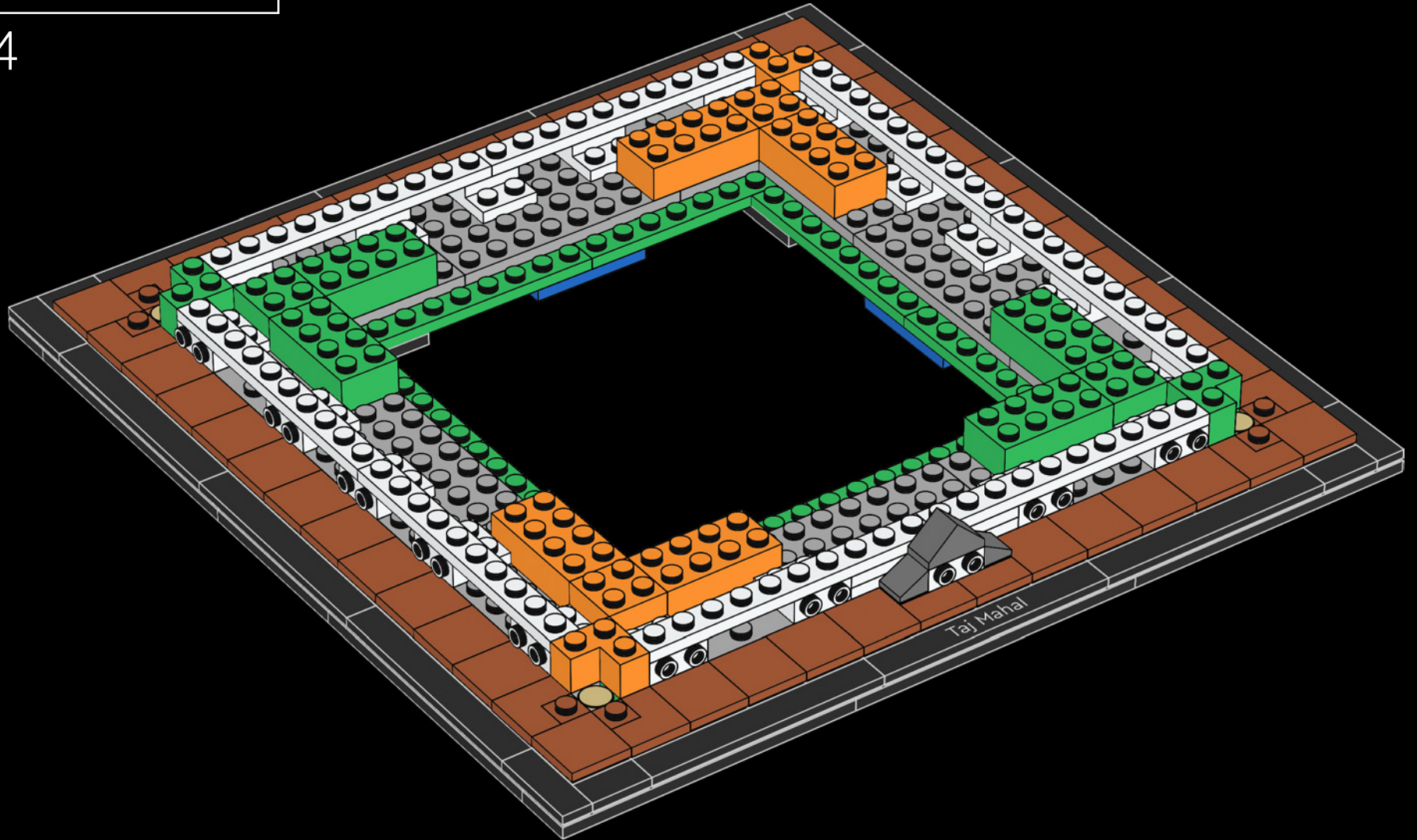

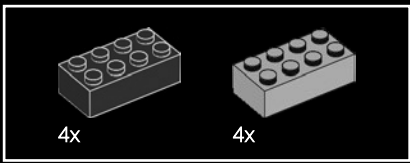

25

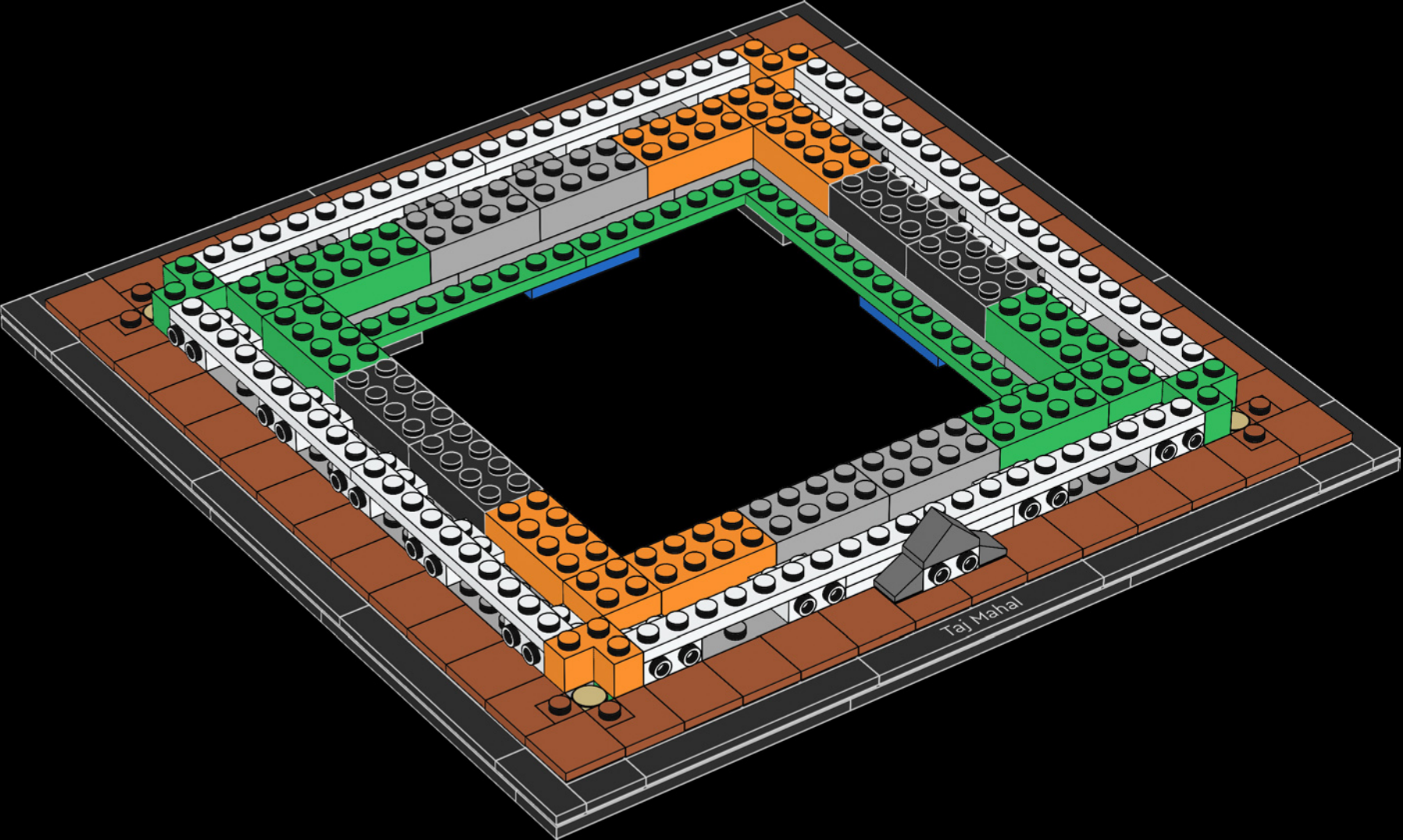

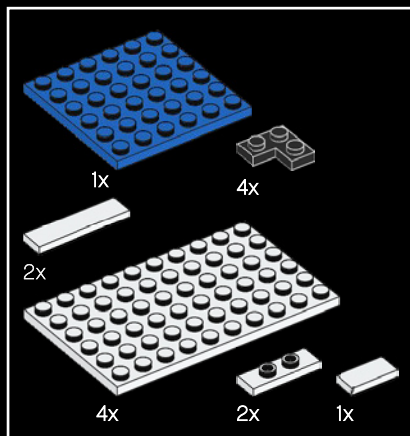

26

Ustad Ahmad Lahauri, generally regarded as the chief architect of the Taj Mahal, was not Indian but a Persian from Iran.

Ustad Ahmad Lahauri, généralement considéré comme l'architecte en chef du Taj Mahal, n'était pas indien, mais bien d'origine perse (Iran).

Ustad Ahmad Lahauri, generalmente considerado el arquitecto principal del Taj Mahal, no era indio, sino persa (de Irán).

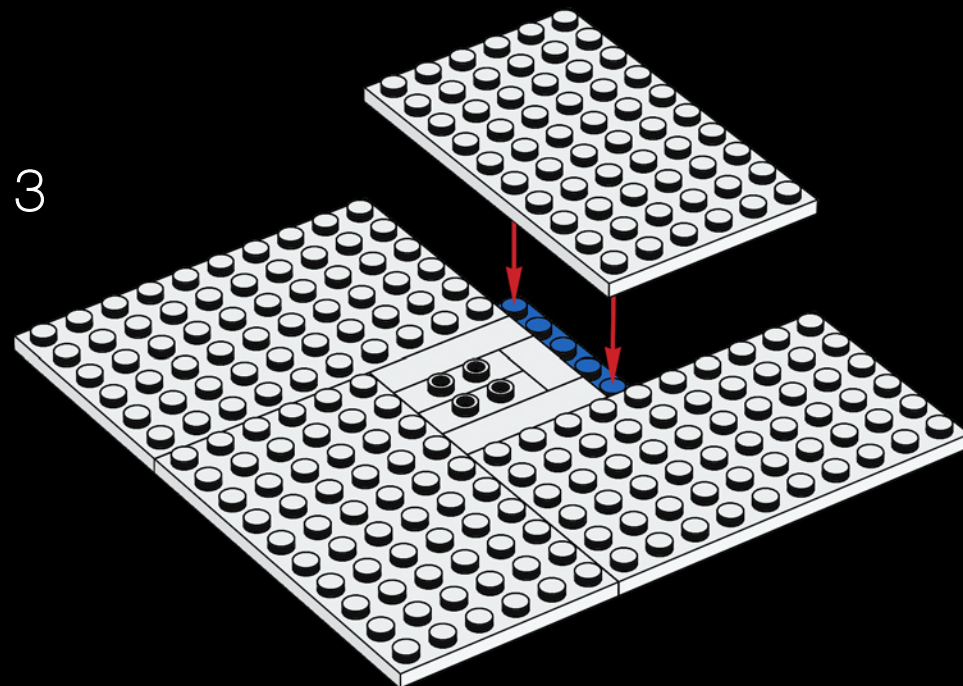
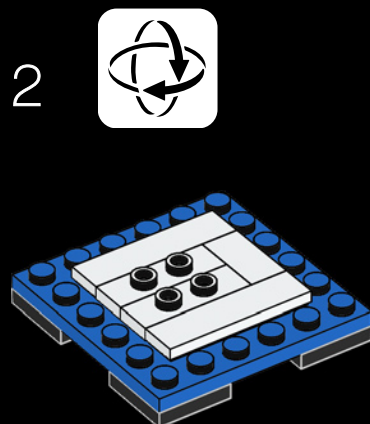
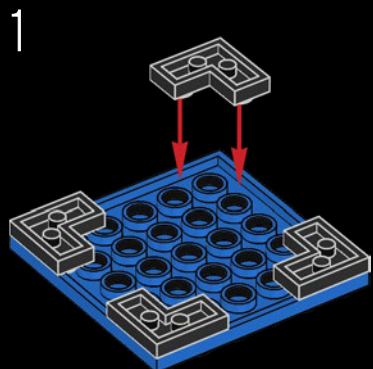
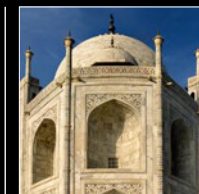

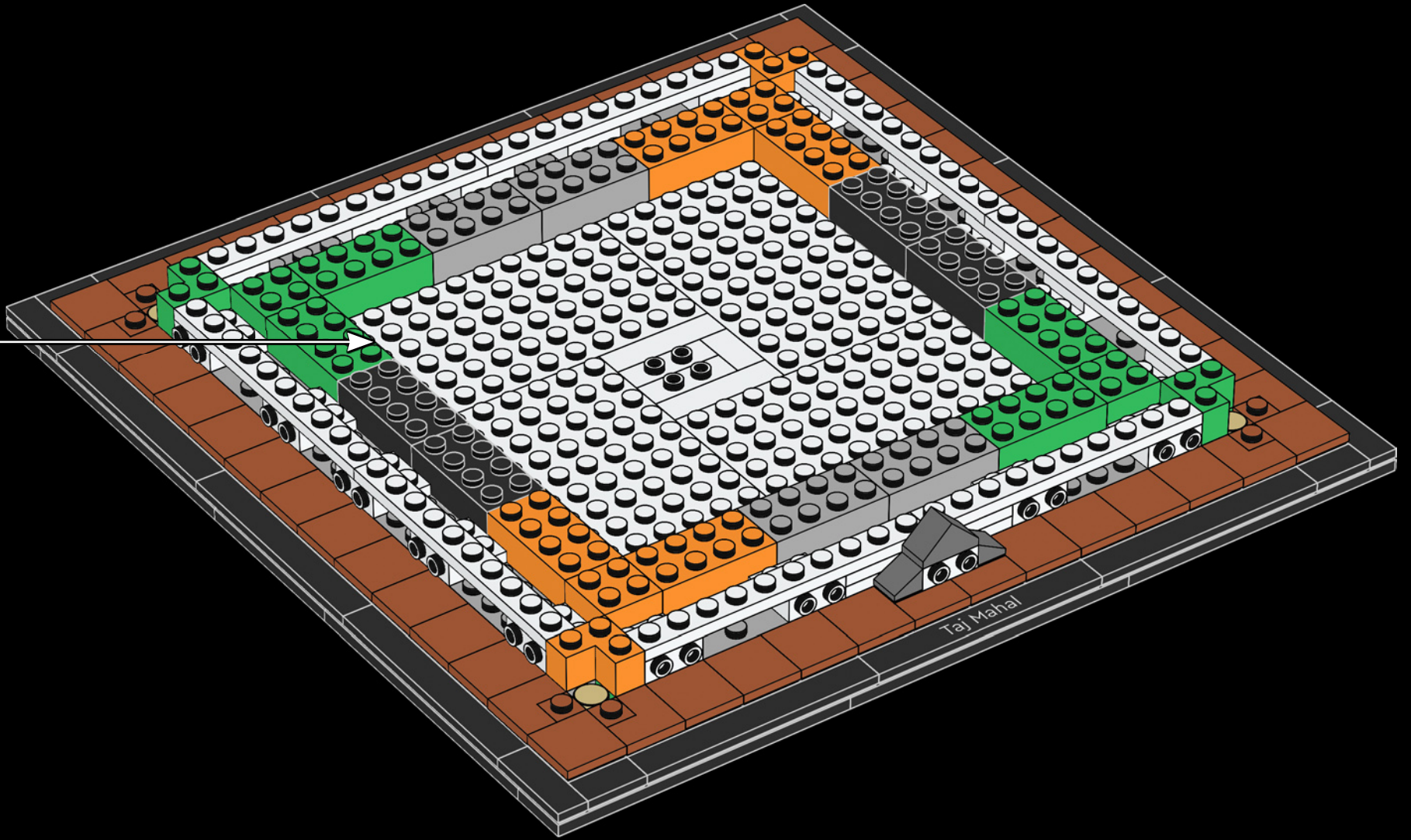

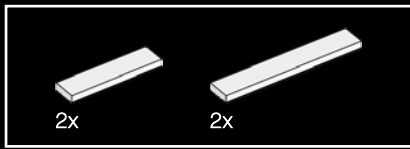

27

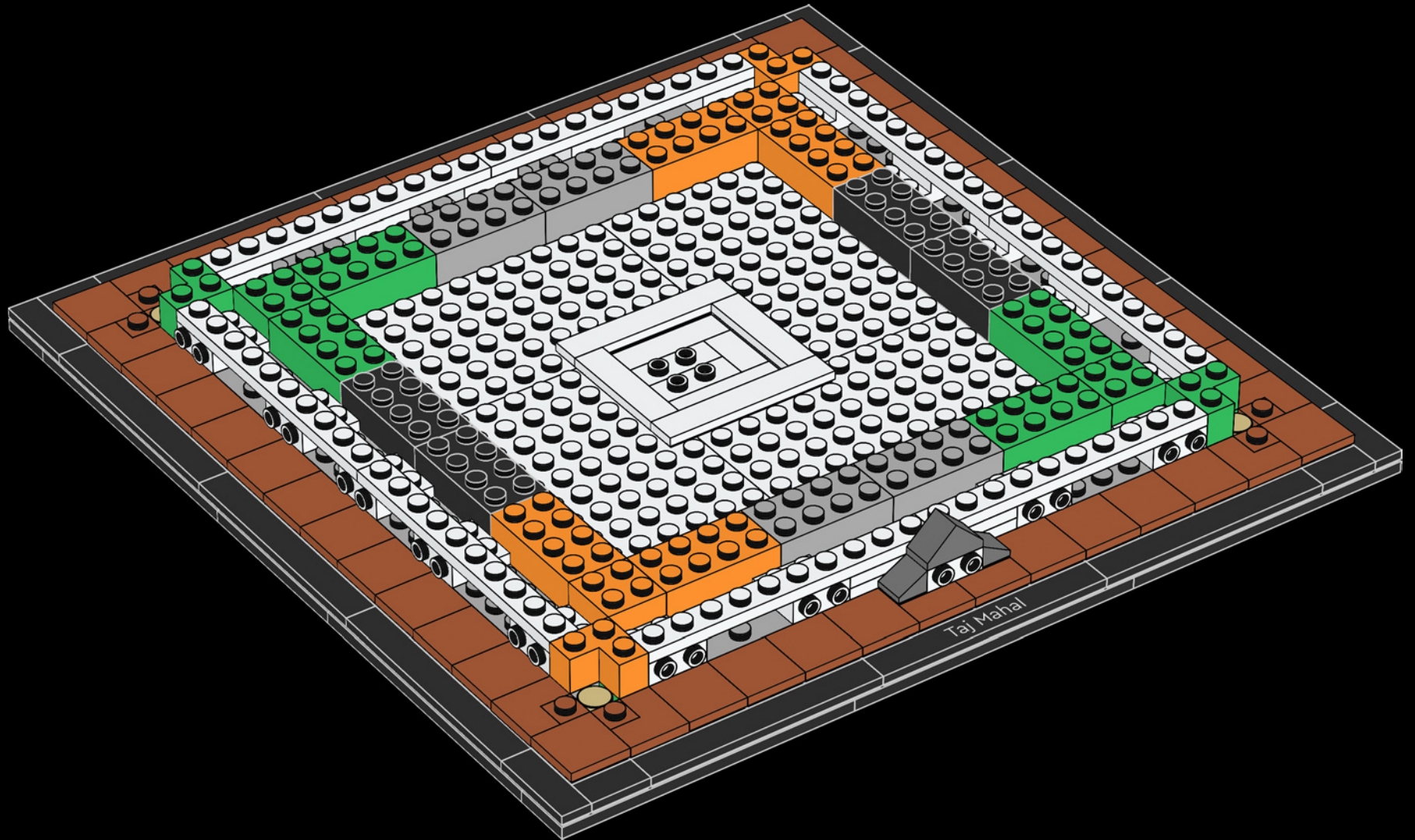

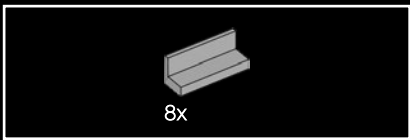

28

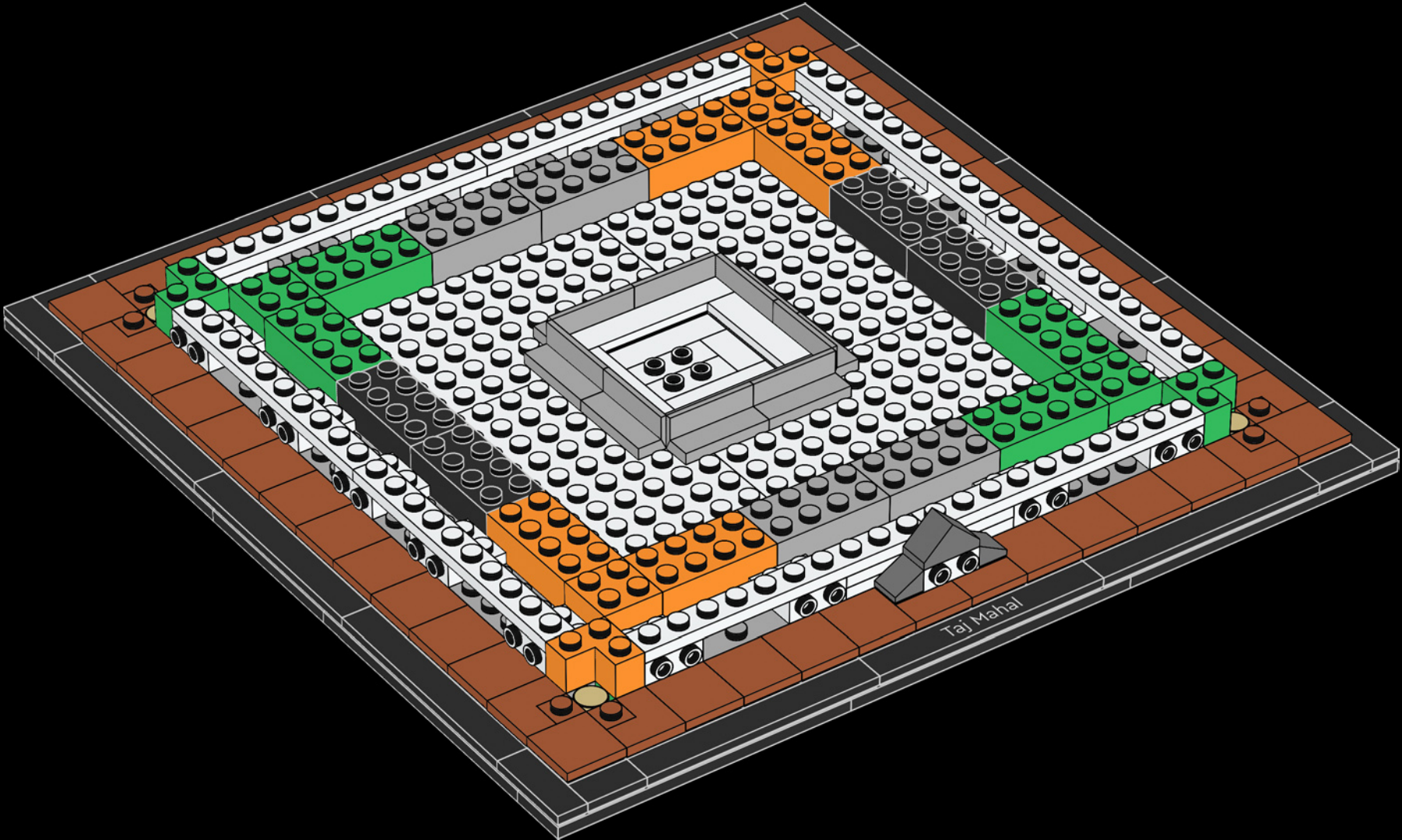

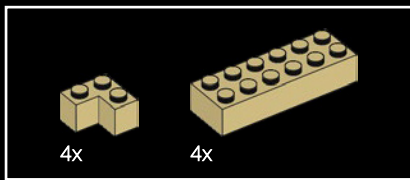

29

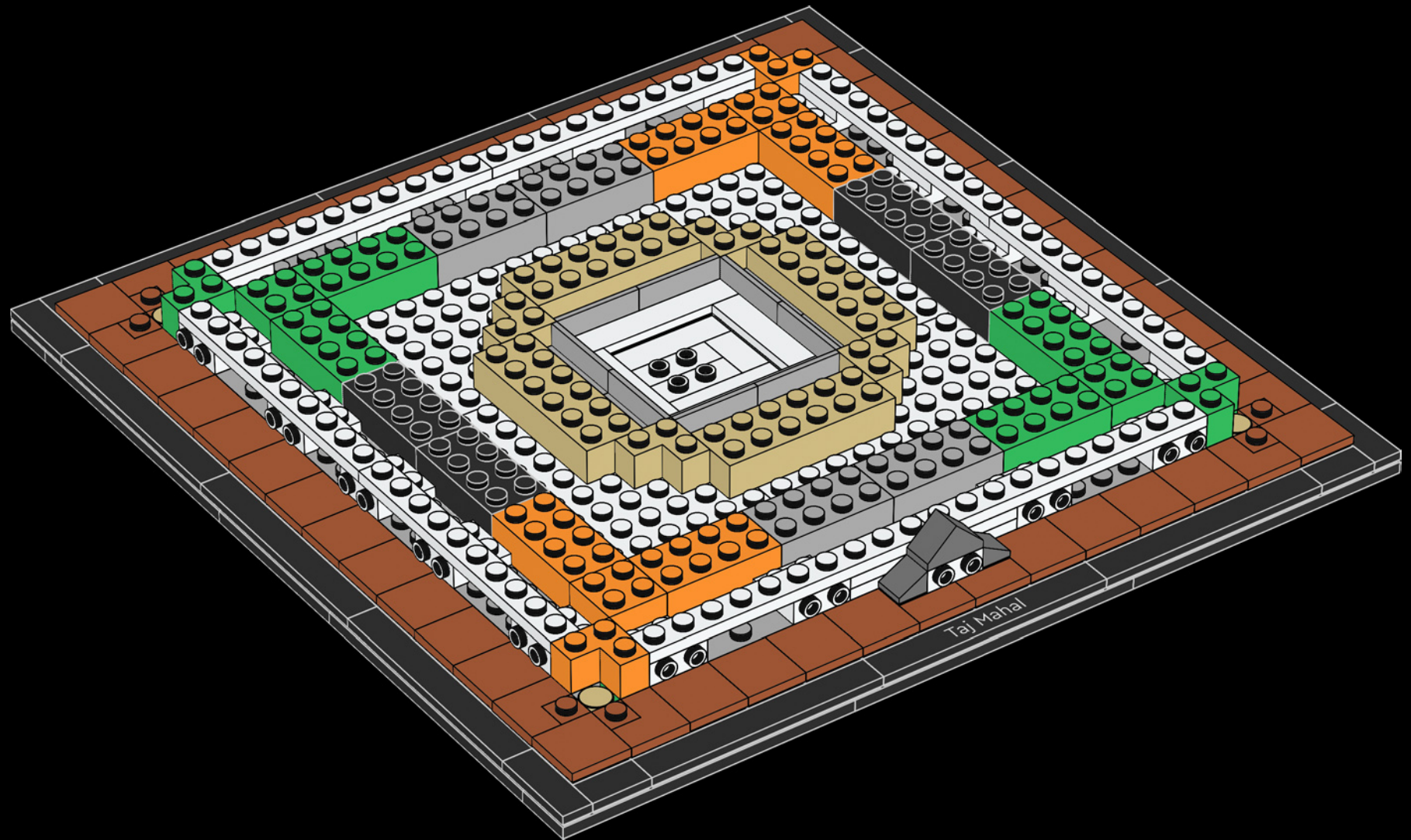



2x

30

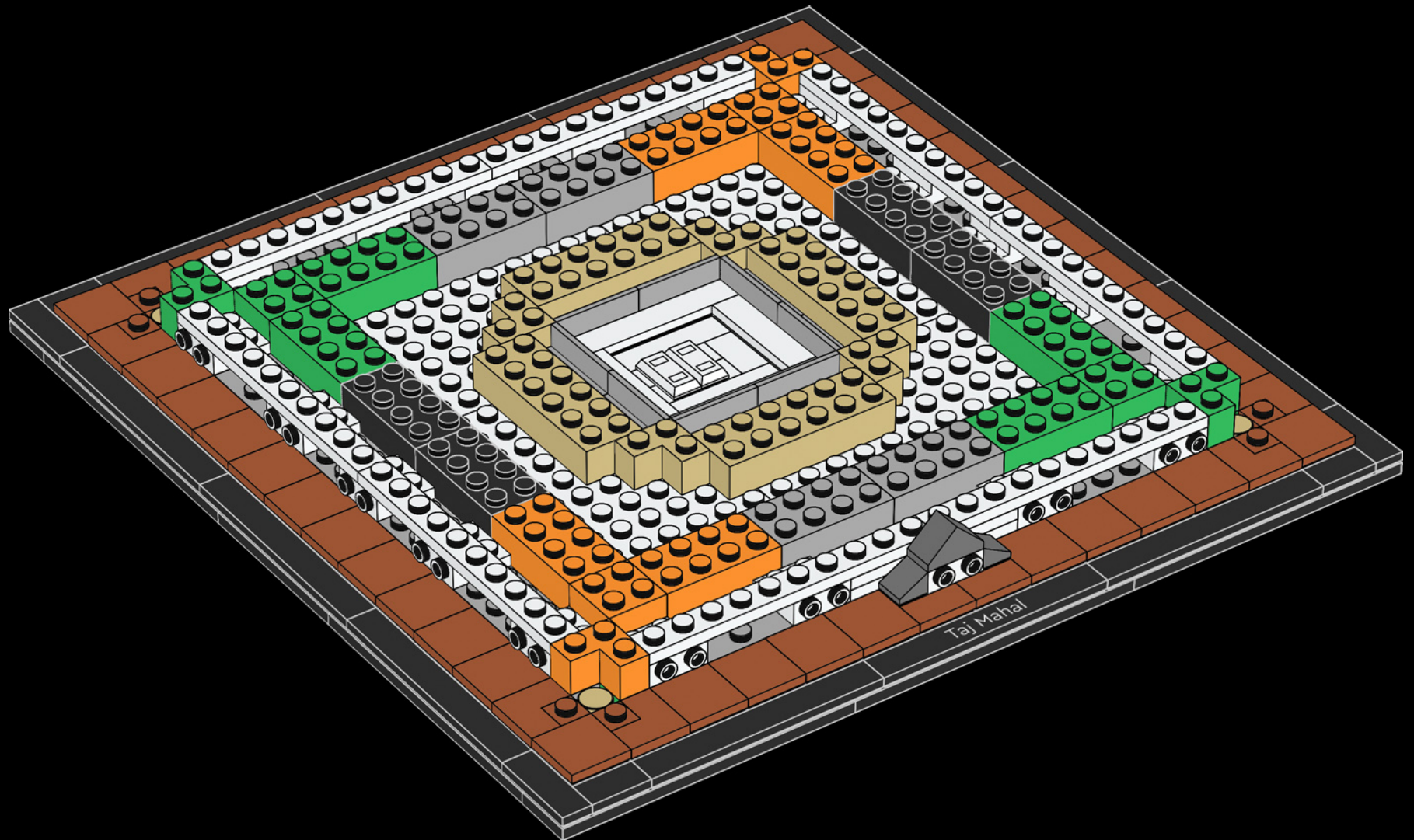

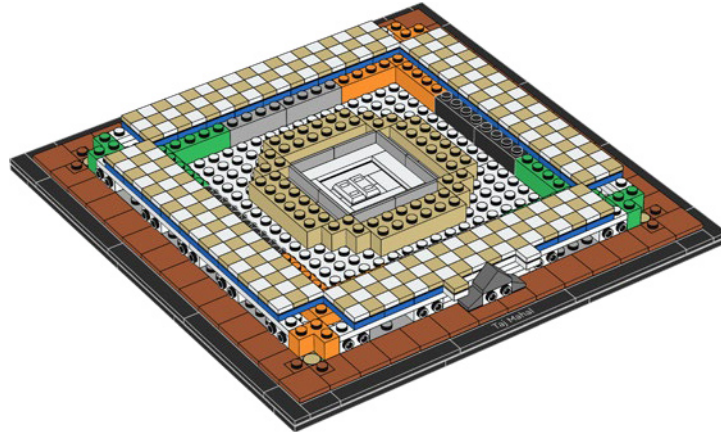
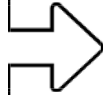



31

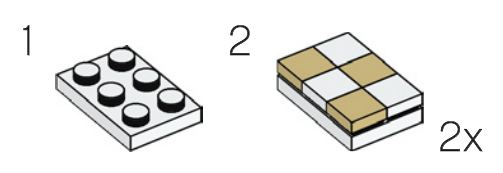
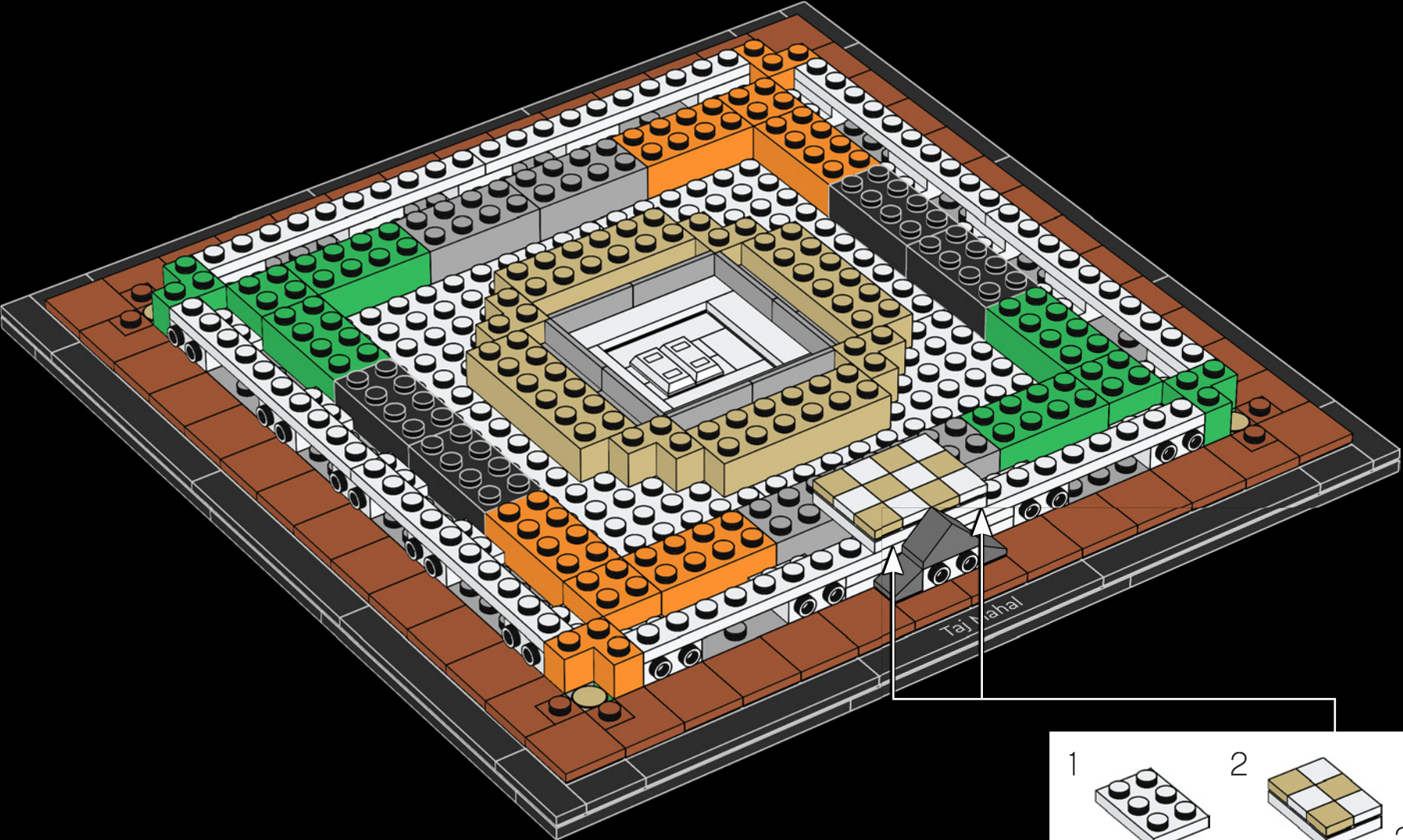



32

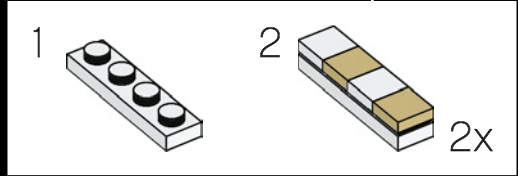
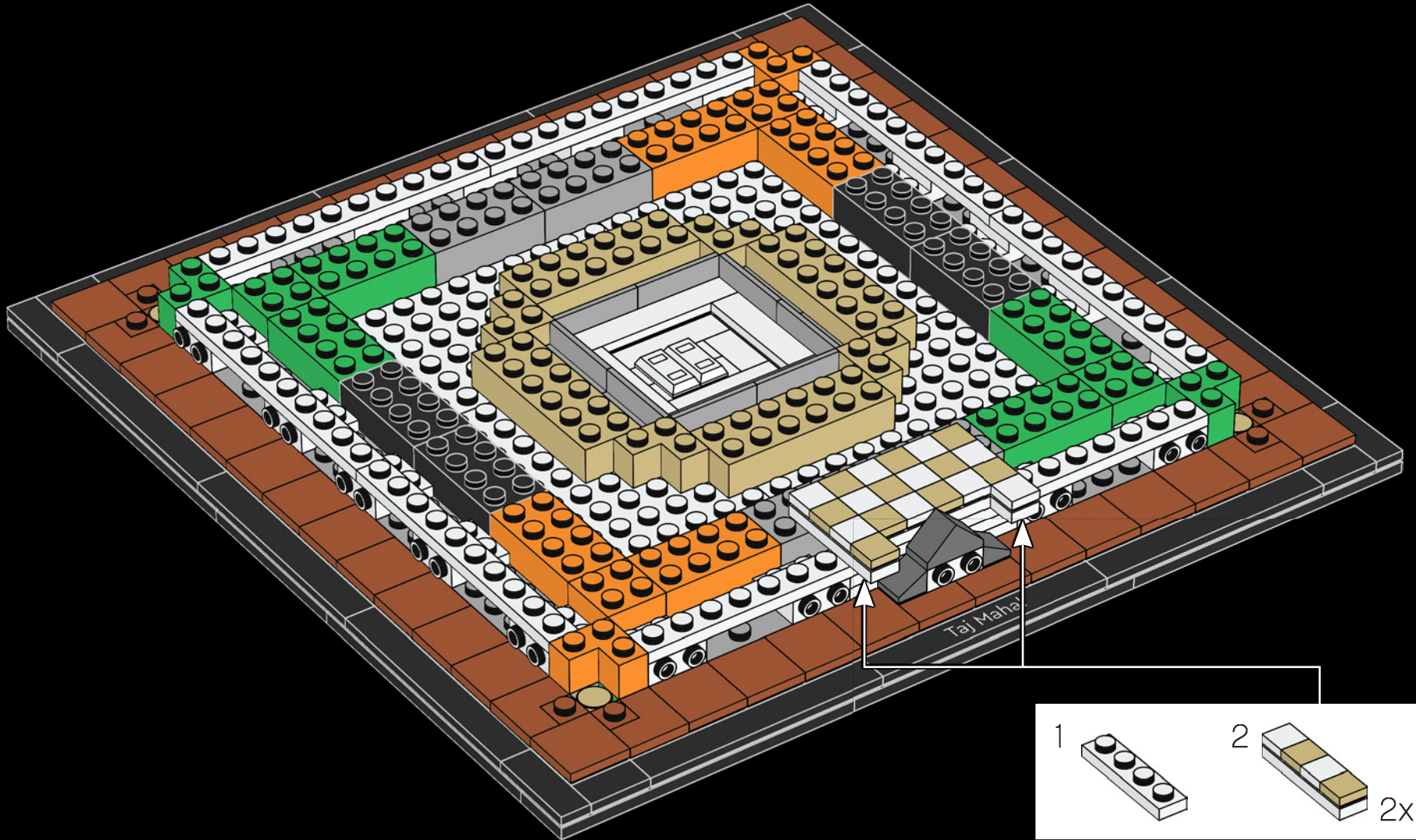

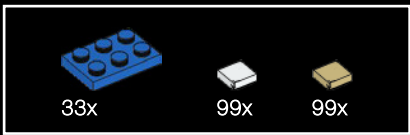

33

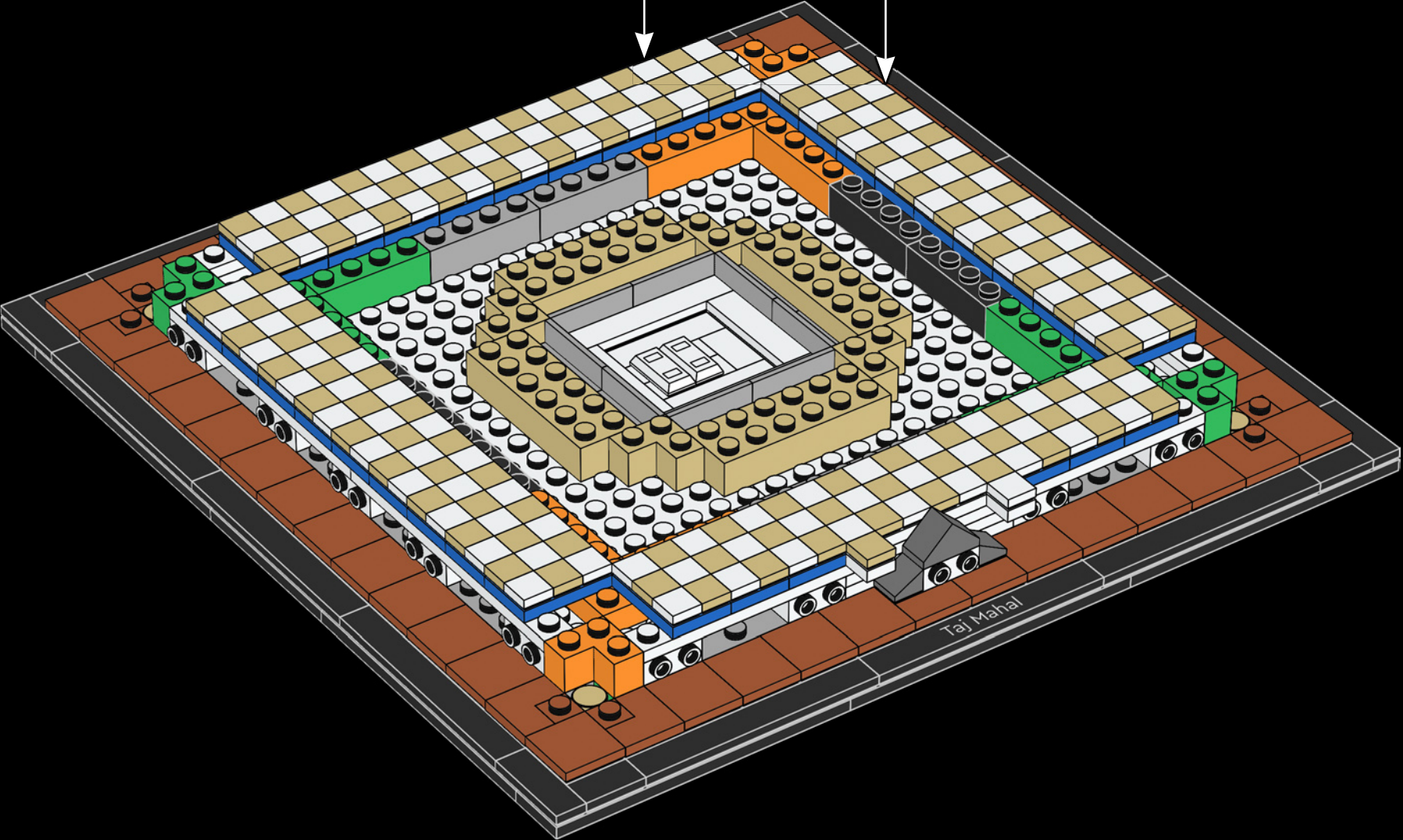
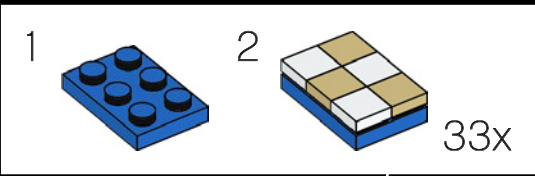

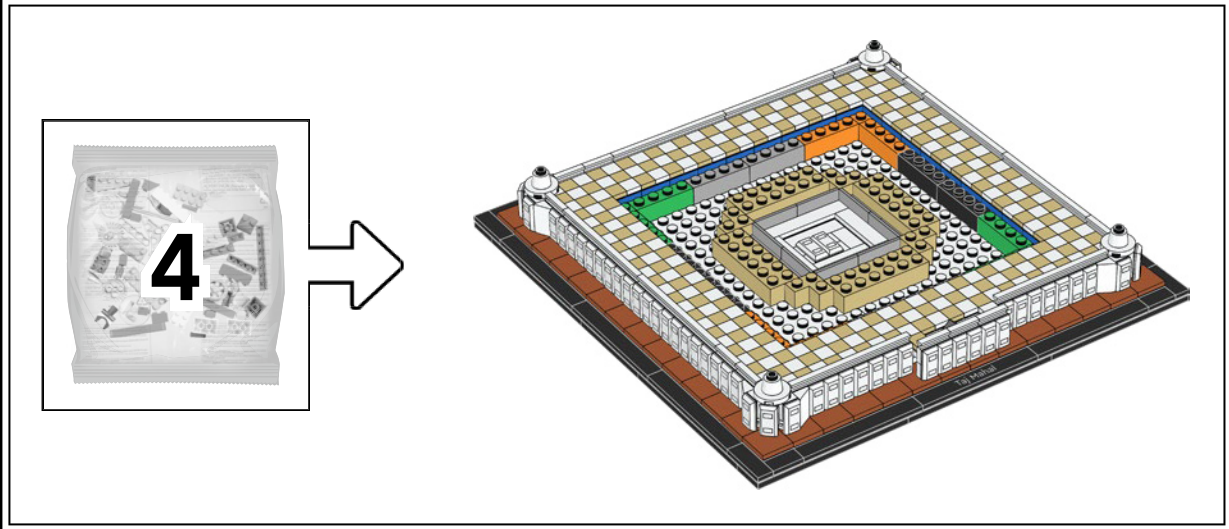



16x

34



8x

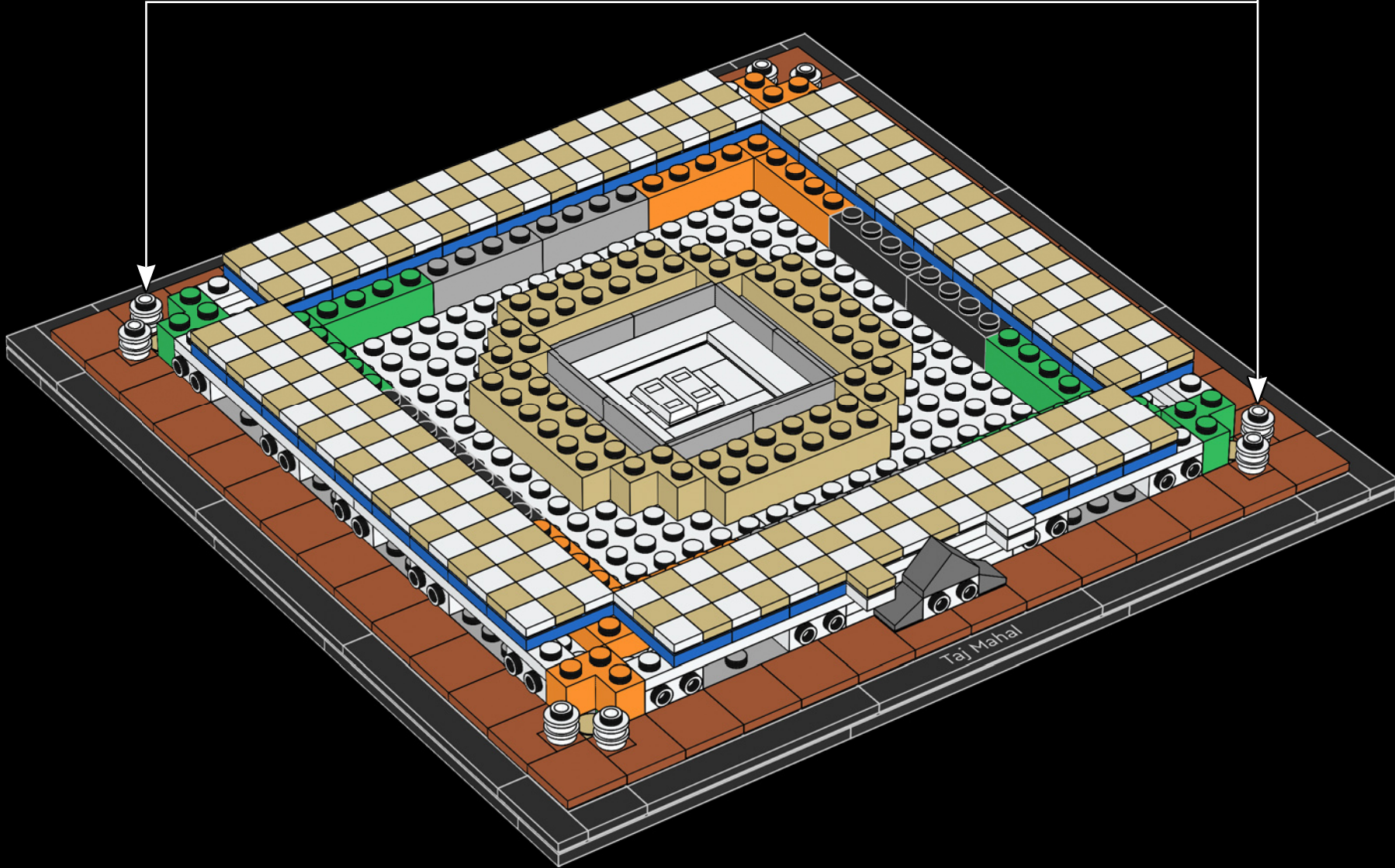

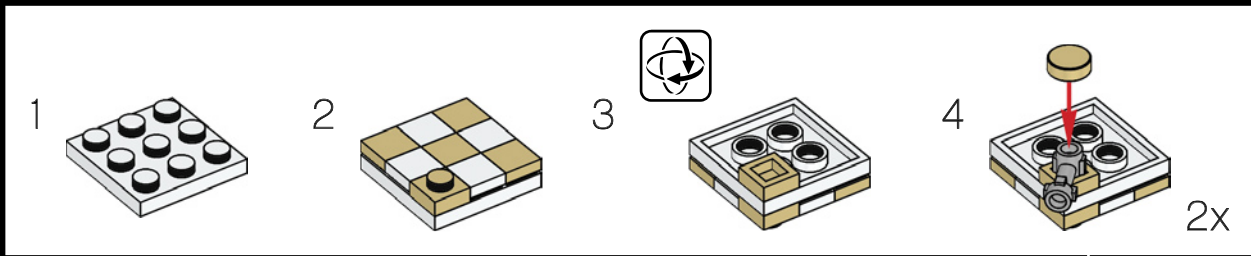
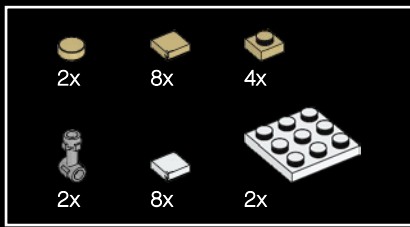

35

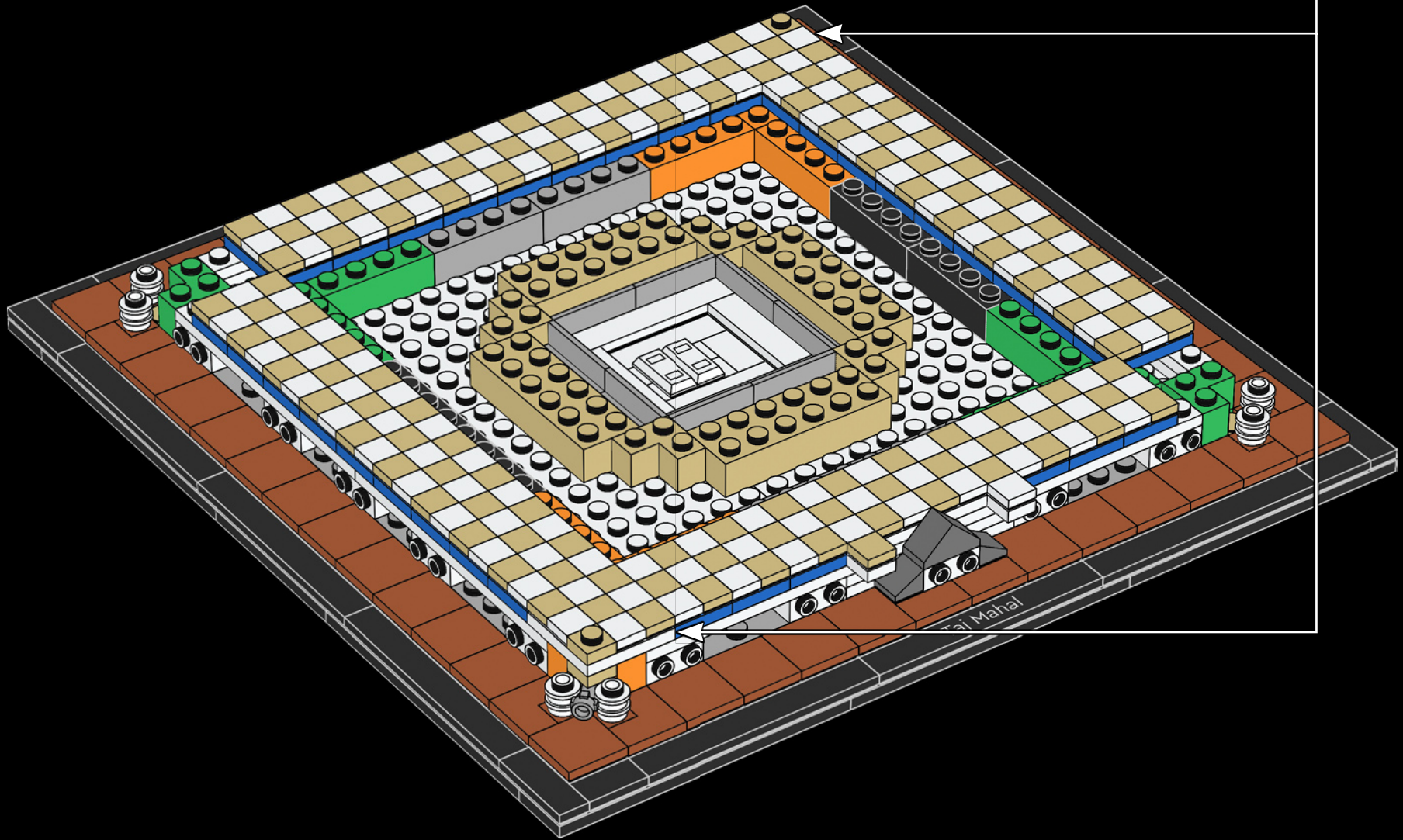

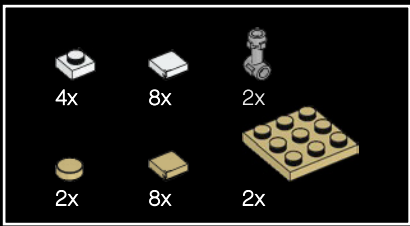

36

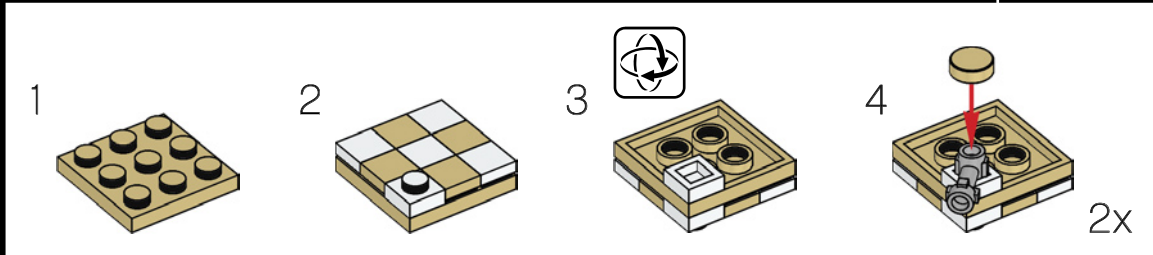
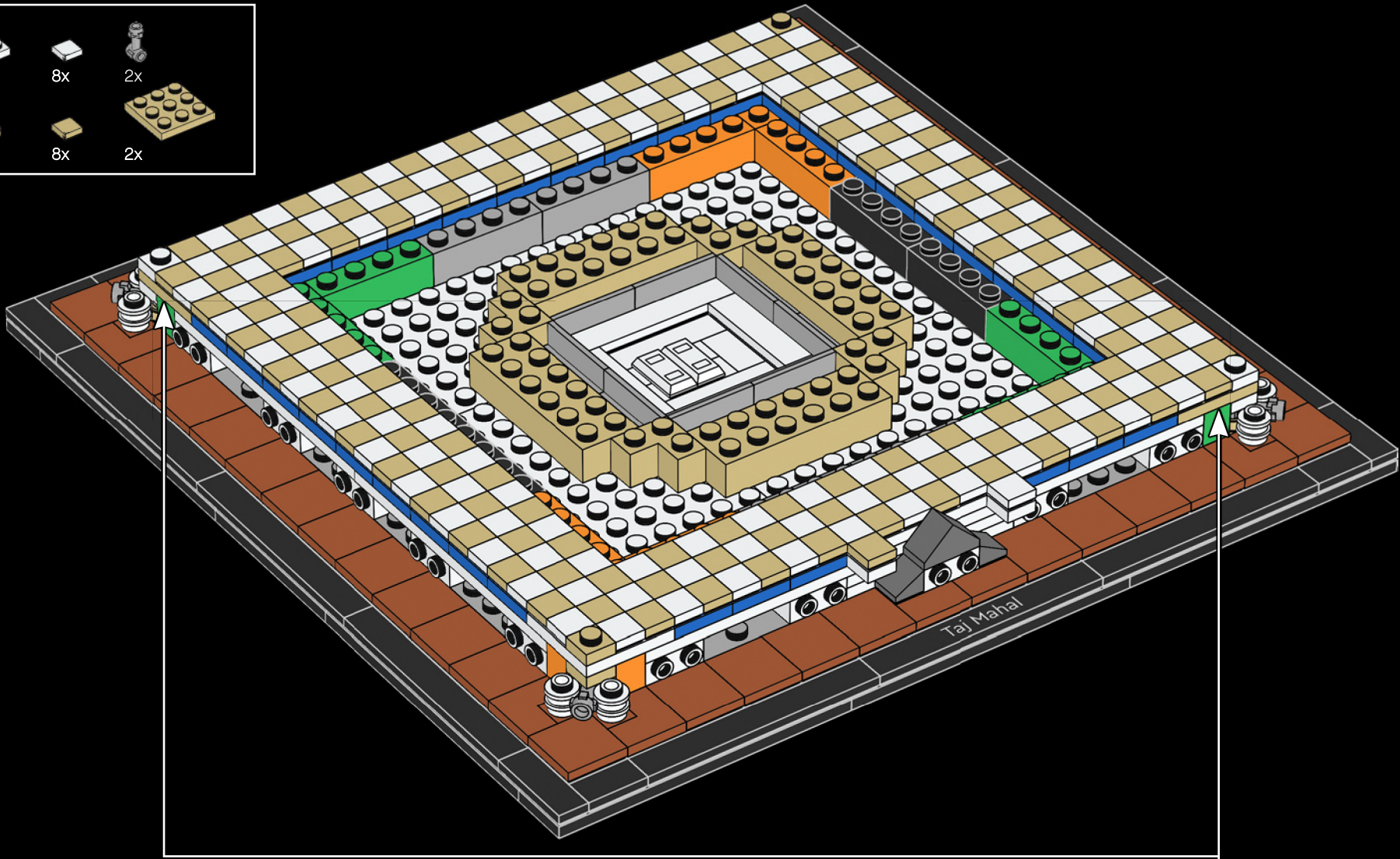

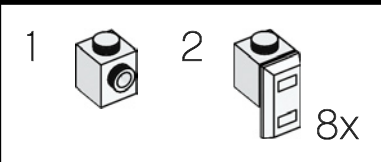
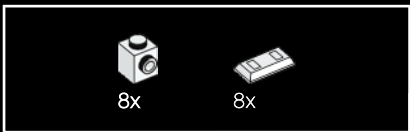

37

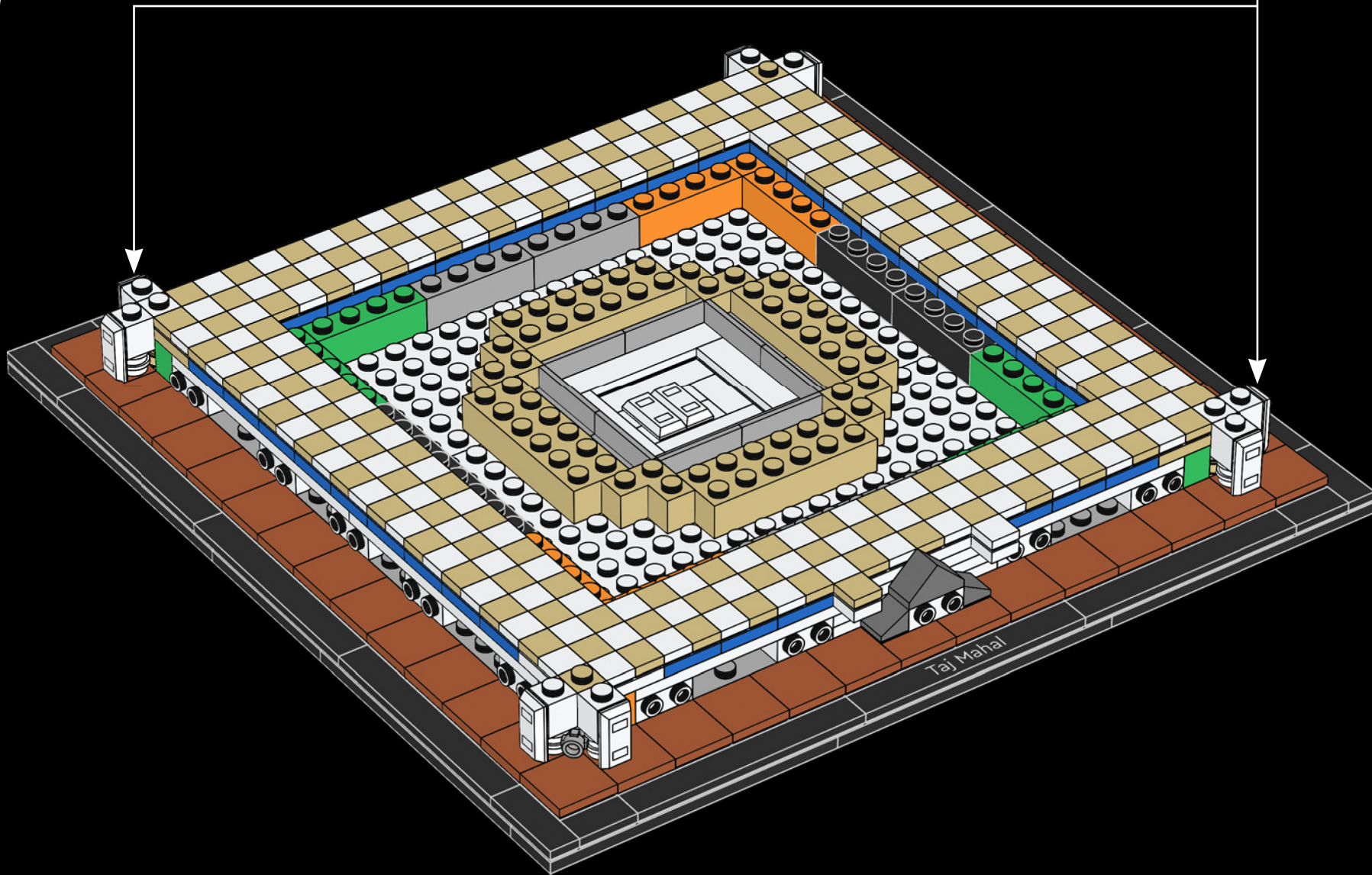



38

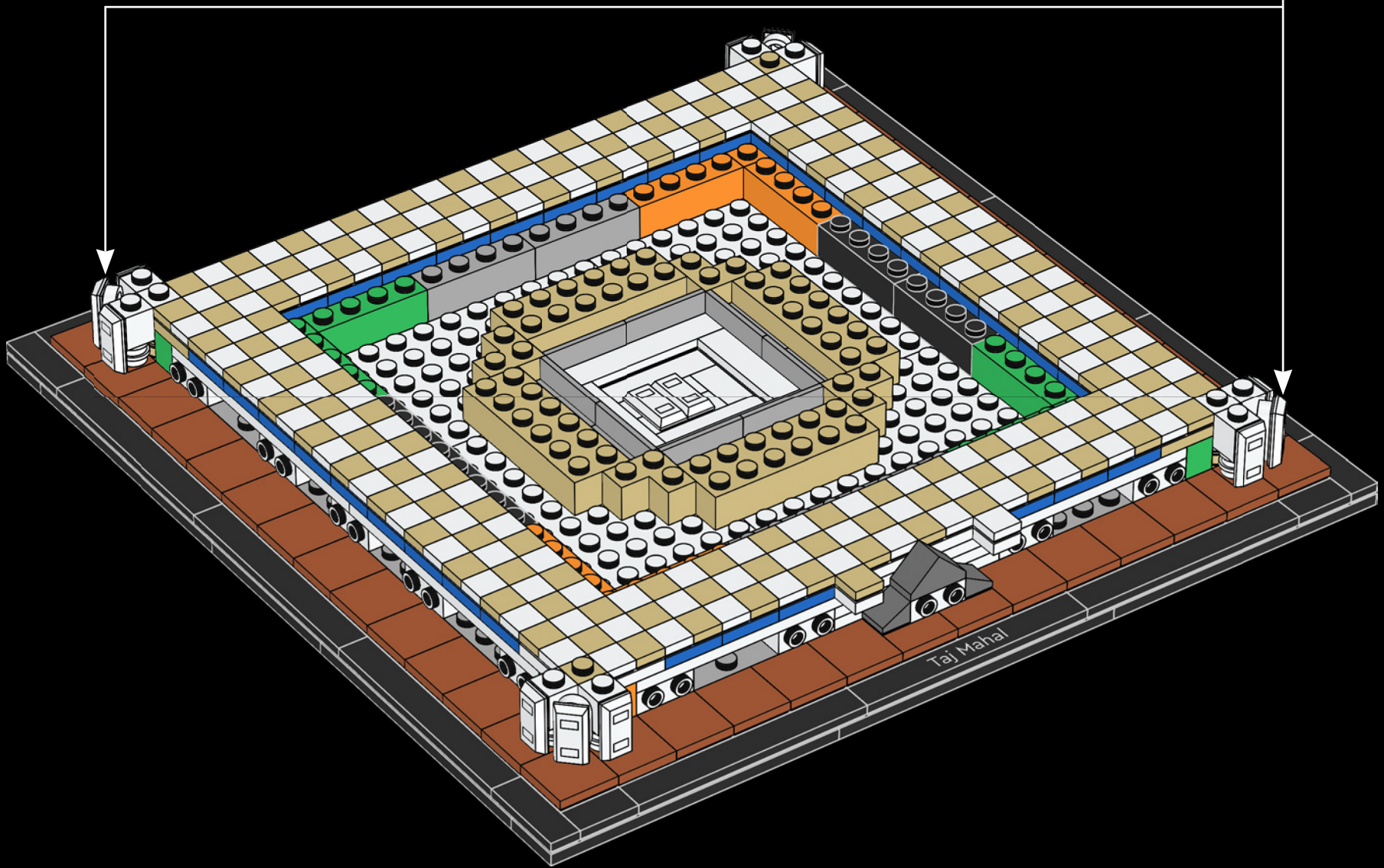
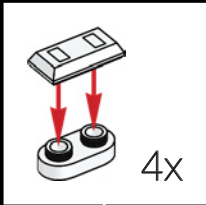



39

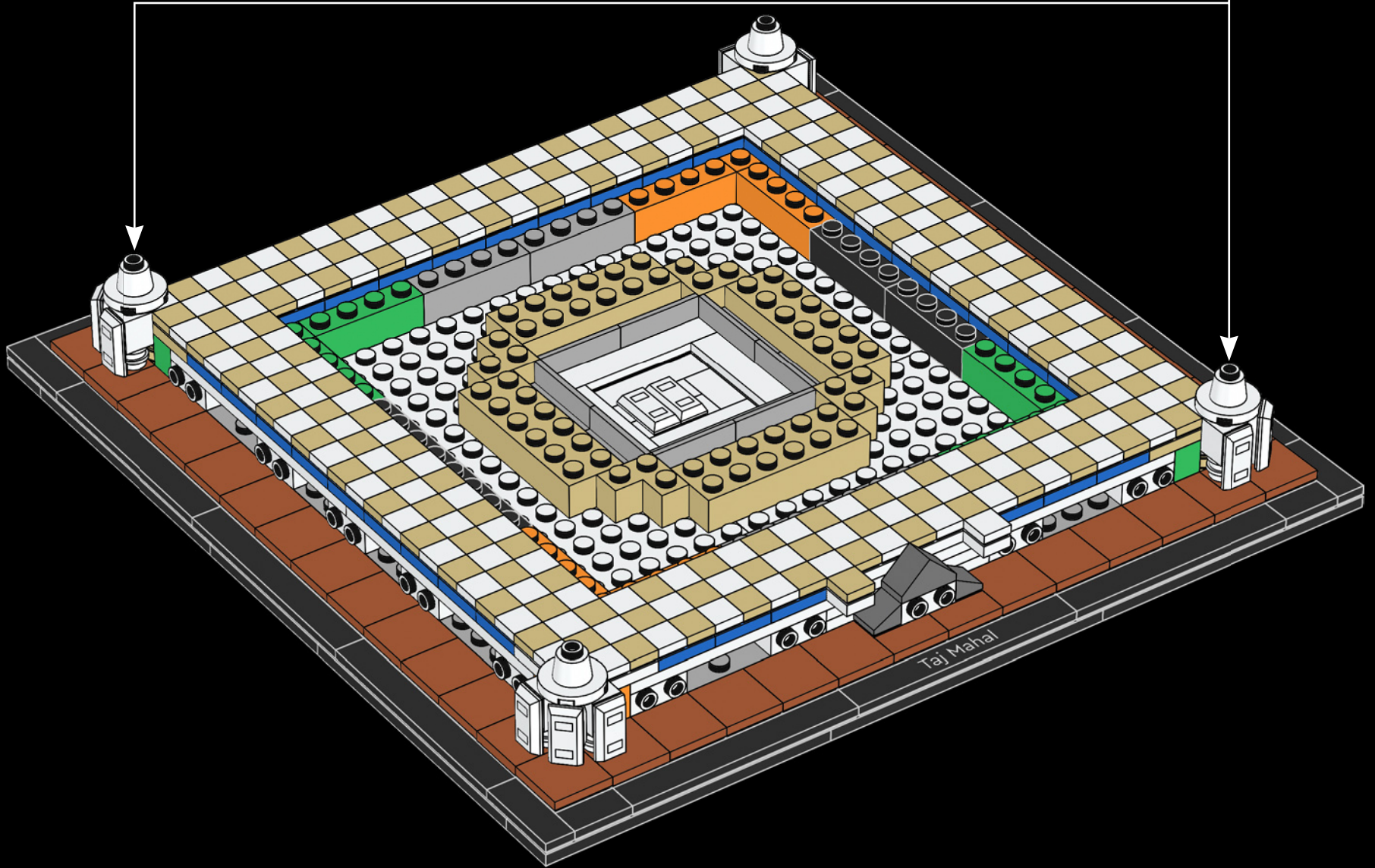
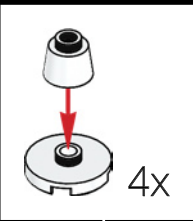

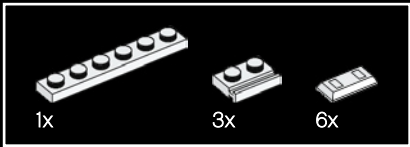

40

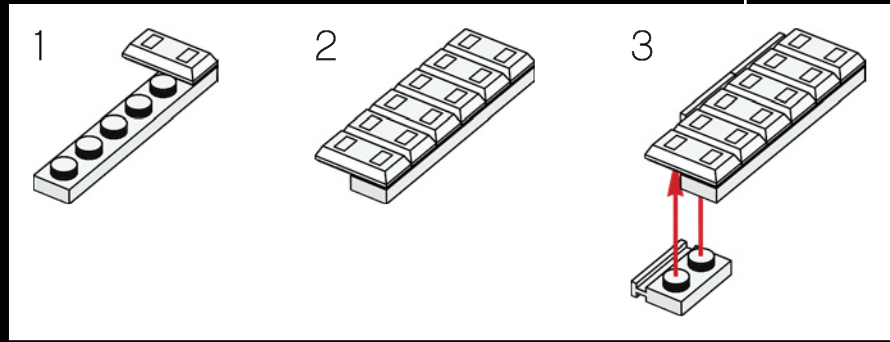
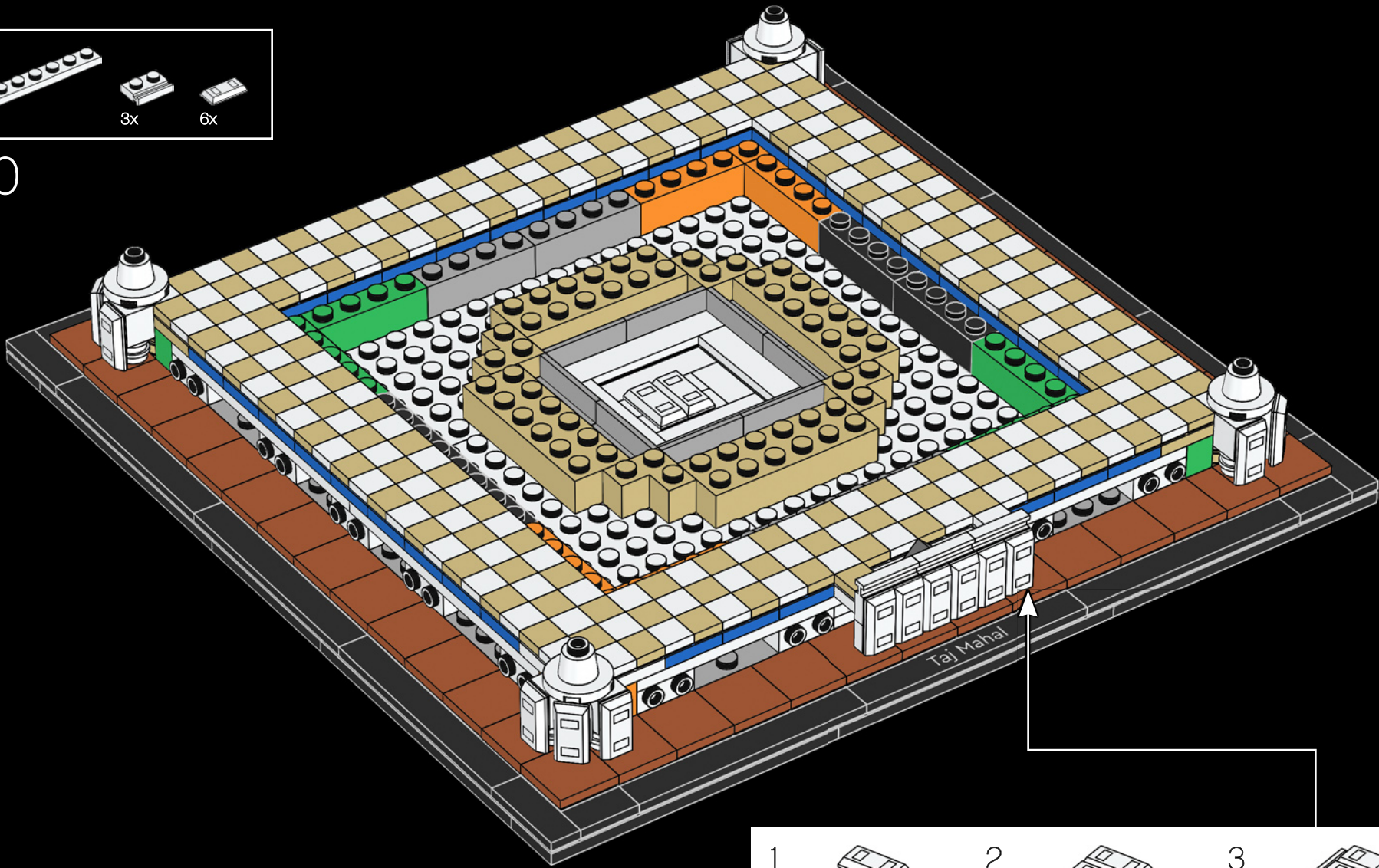

50

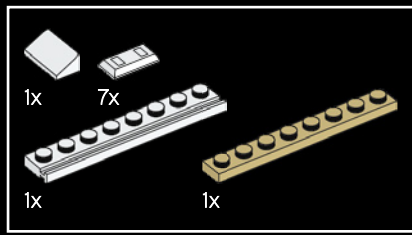

41

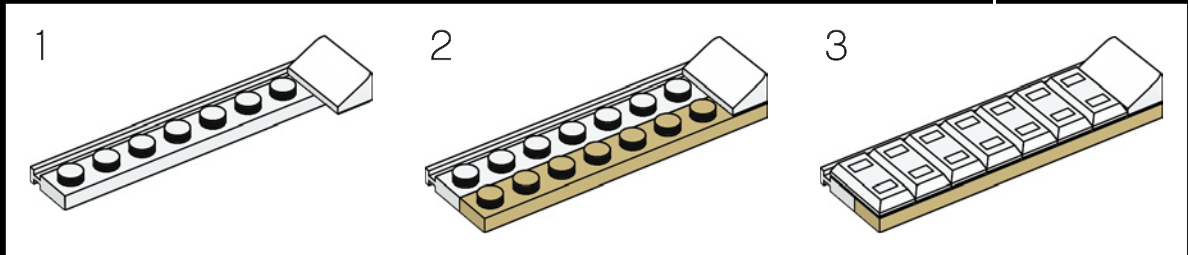
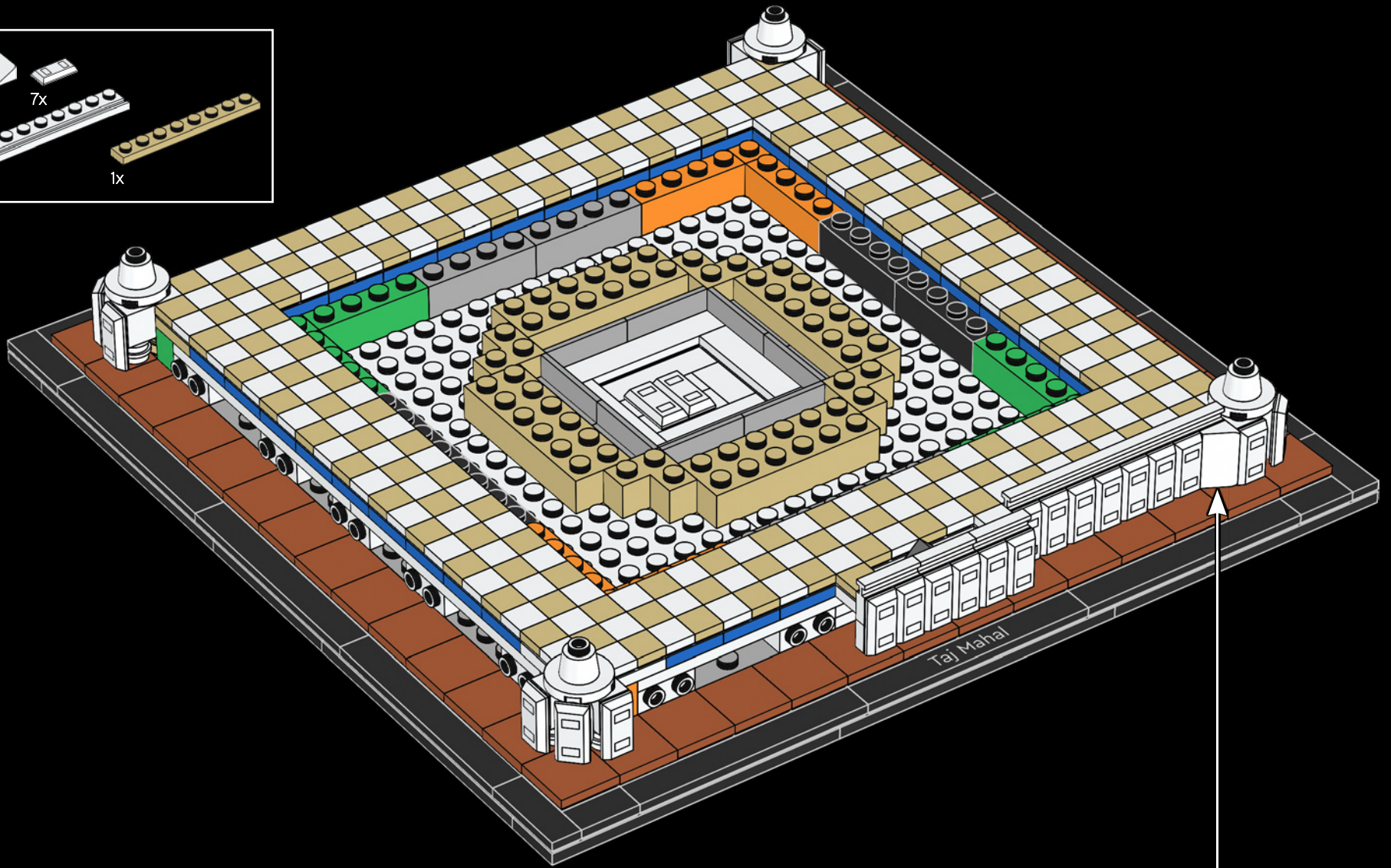

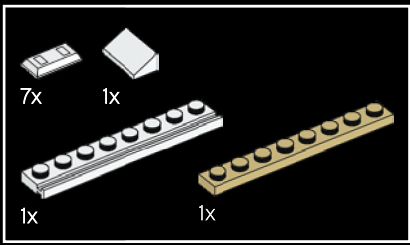

42

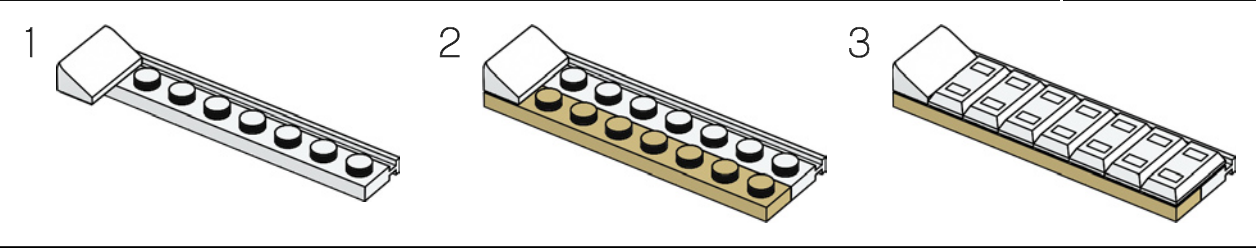
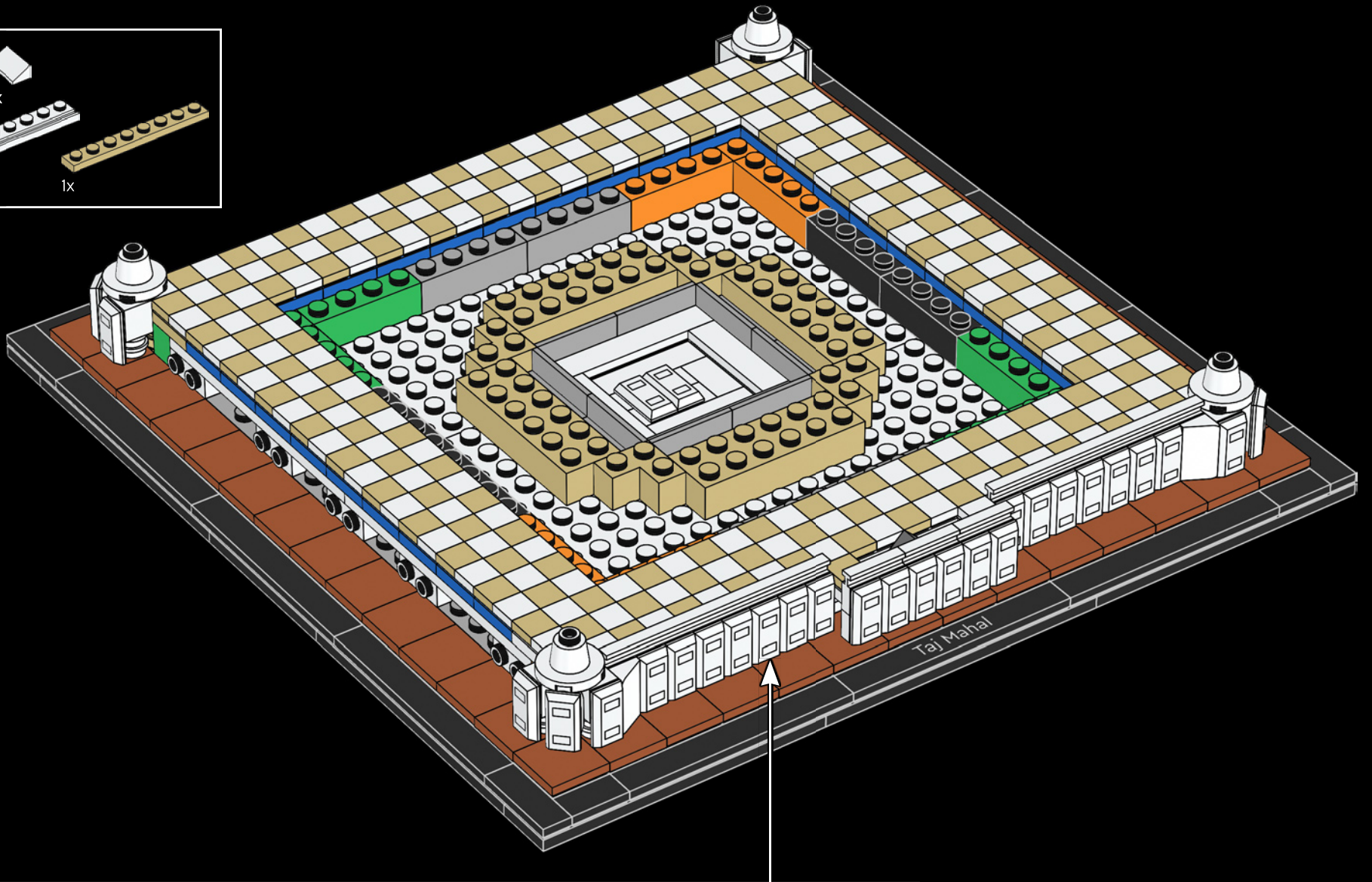

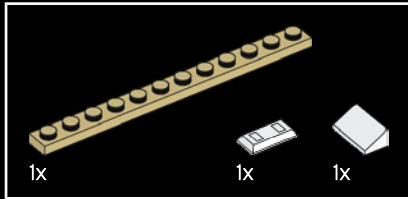
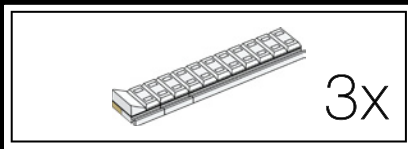

43

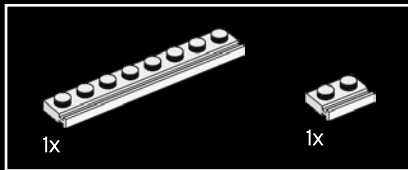
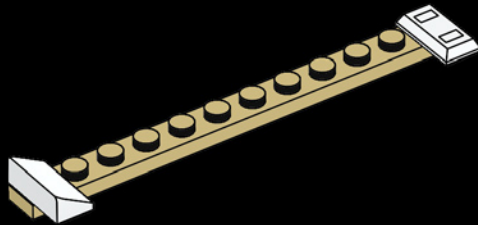

44

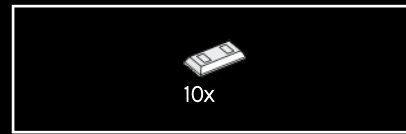
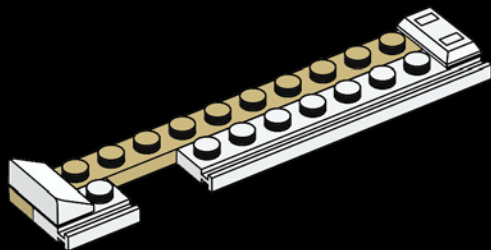

45

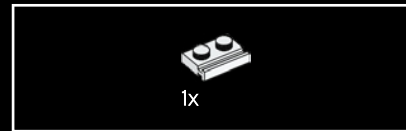
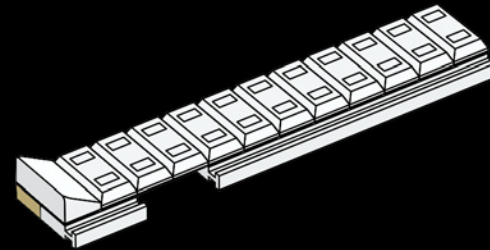

46

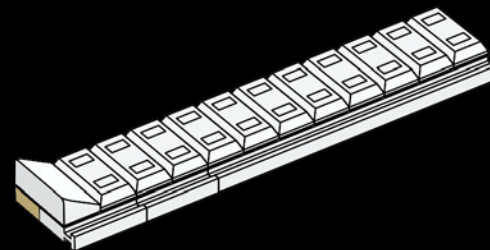

3x

47

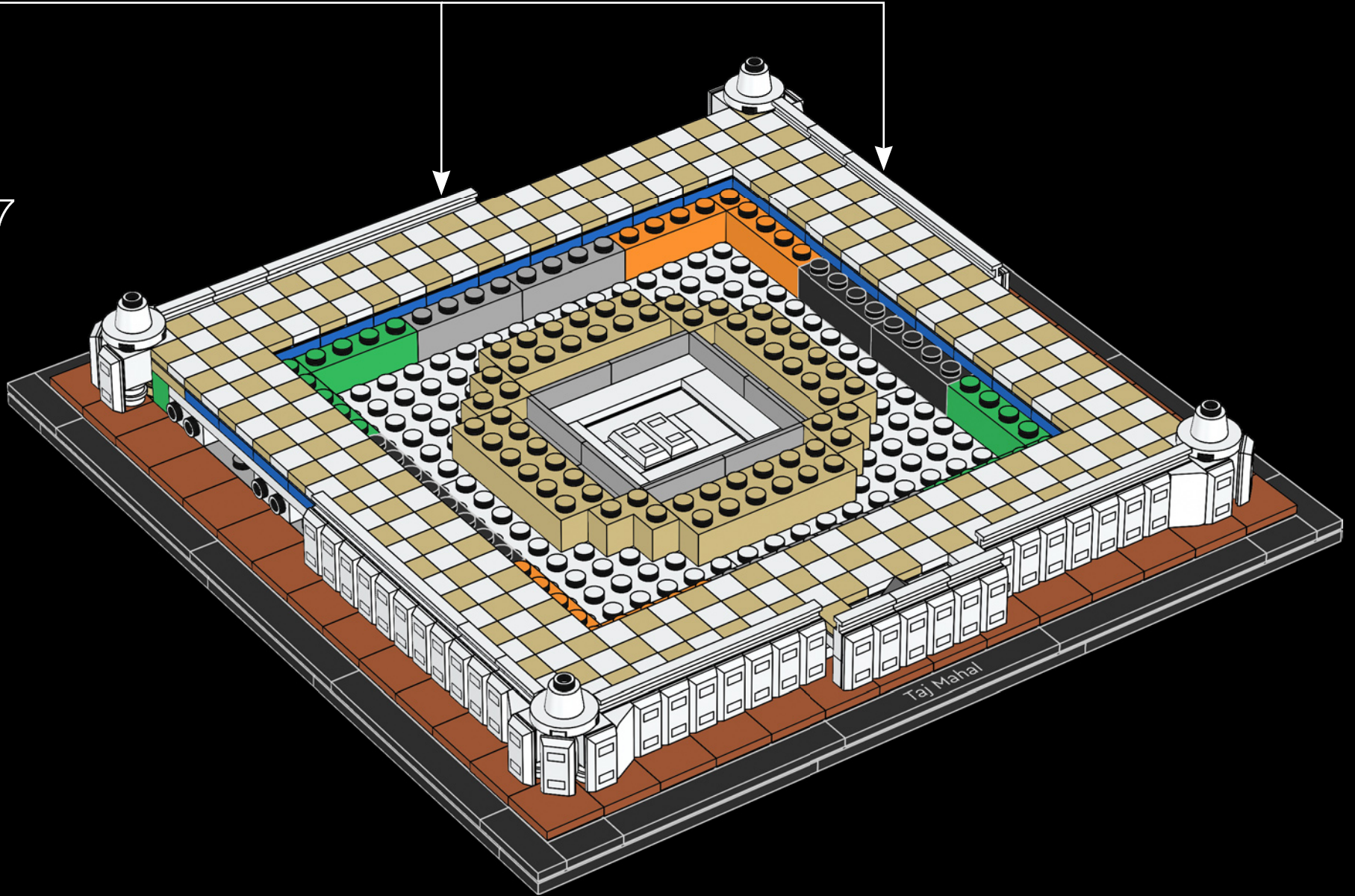

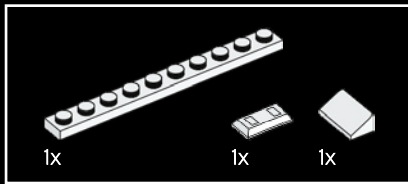
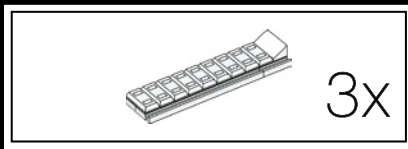

48

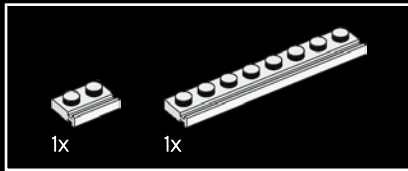
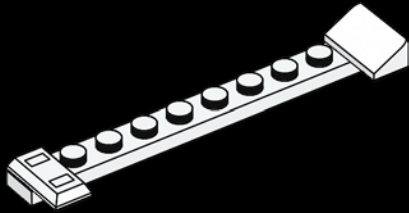

49

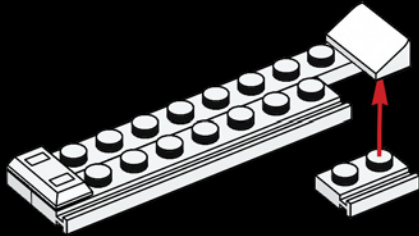

50

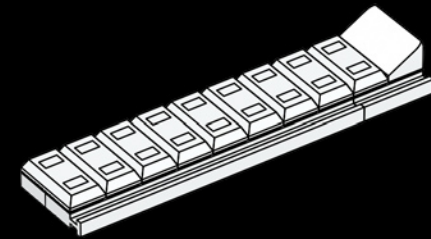

3x

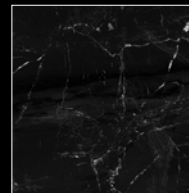

A longstanding myth holds that Shah Jahan planned a mausoleum to be built in black marble as a Black Taj Mahal across the Yamuna river.

Une vieille légende soutient que Shâh Jahân avait prévu de construire un mausolée en marbre noir, une réplique noire du Taj Mahal, sur l'autre rive de la rivière Yamuna.

Según una vieja leyenda, Shah Jahan planeó la construcción de un mausoleo de mármol negro al otro lado del río Yamuna: el Taj Mahal Negro.

51

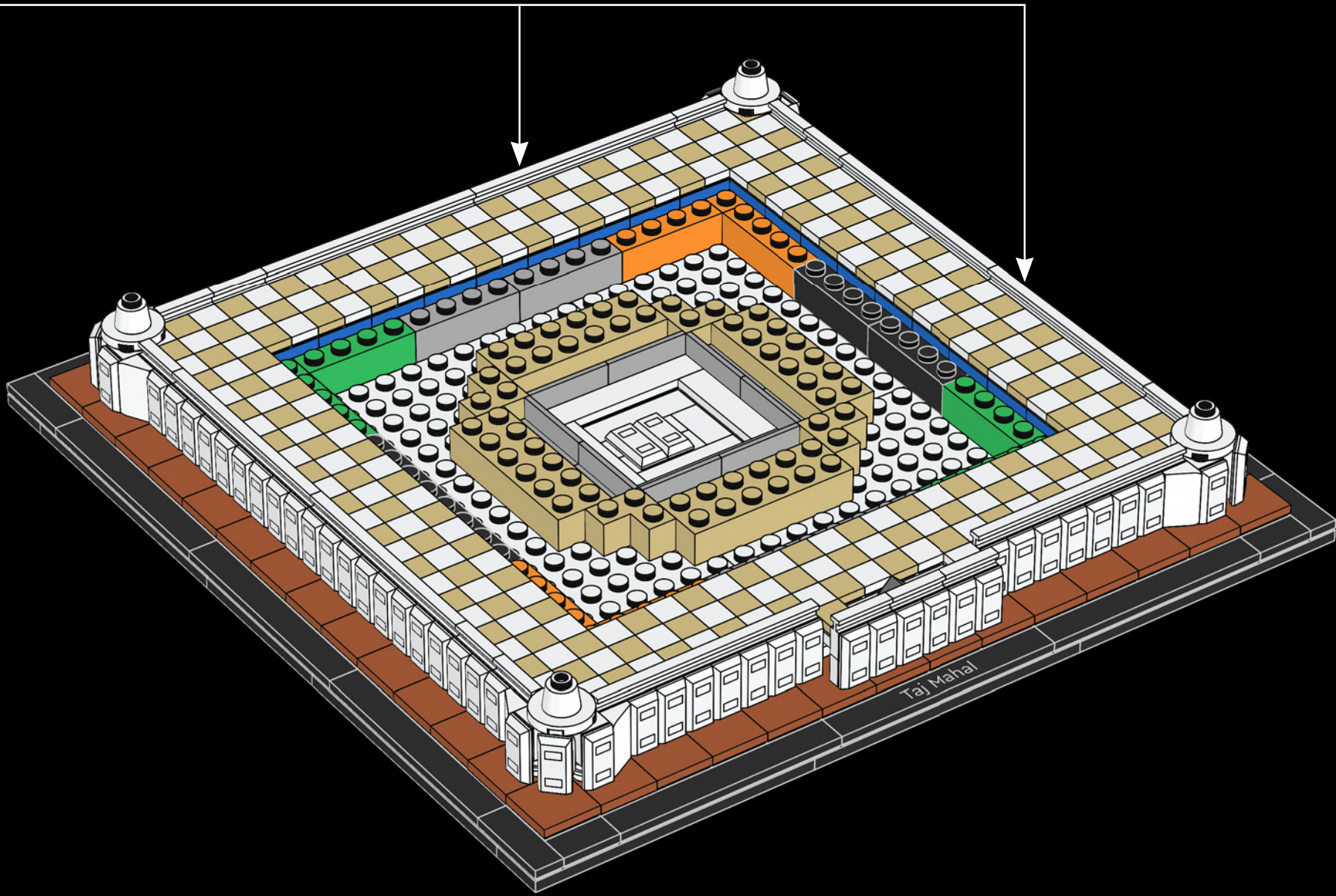

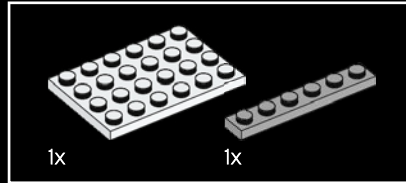
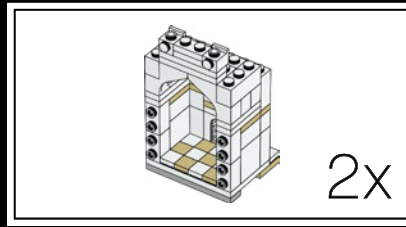
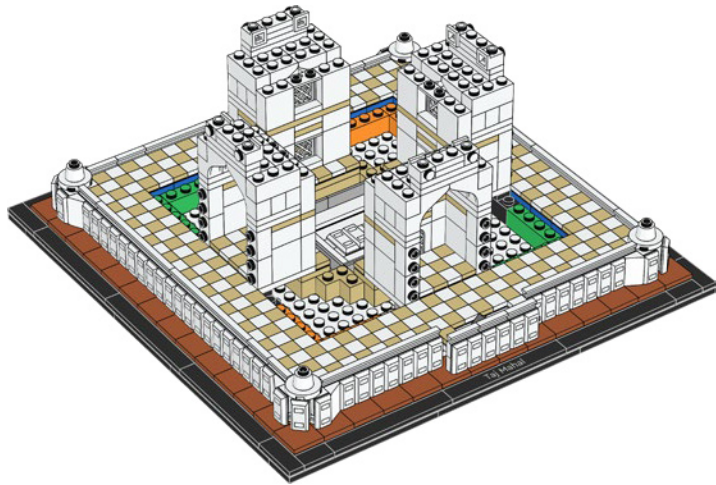
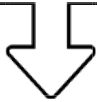

52

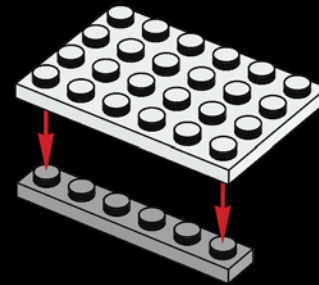

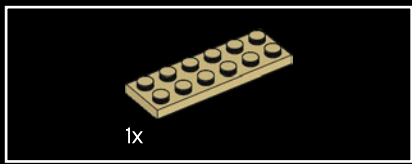

53

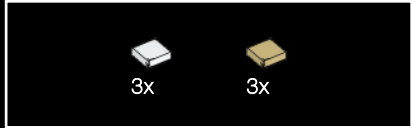
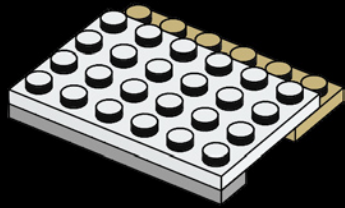

54

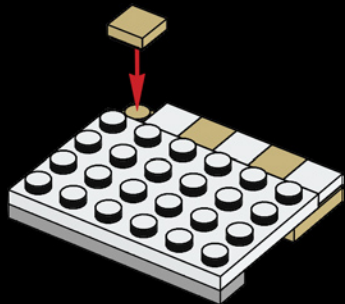

55

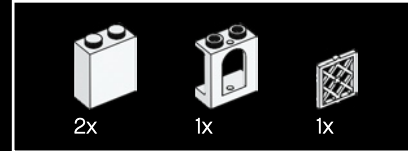
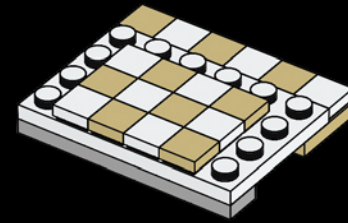

56

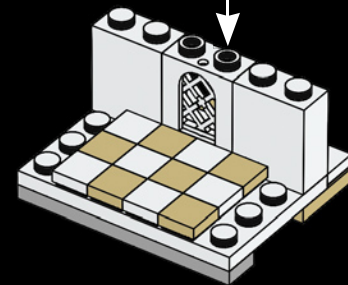
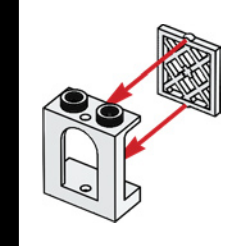



57

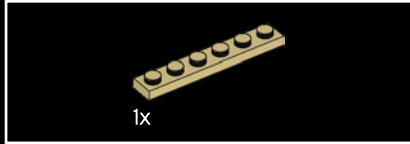
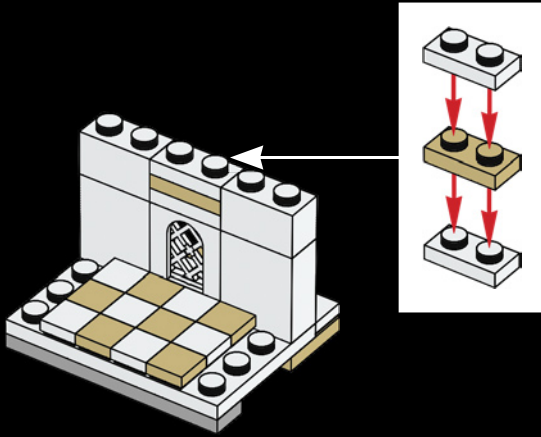

58

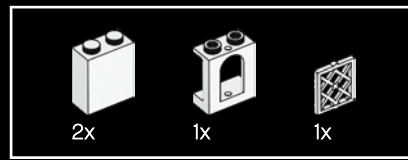
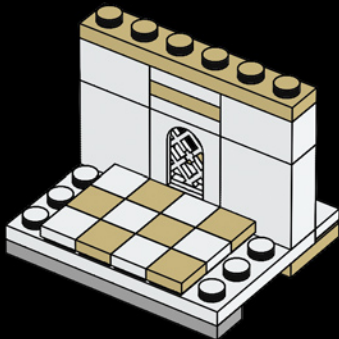

59

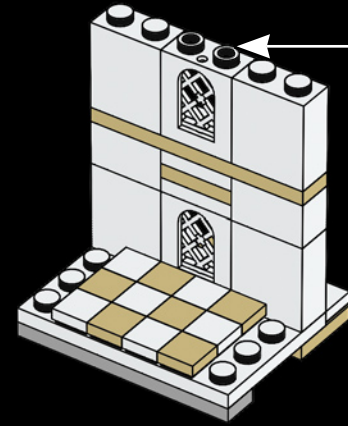

60

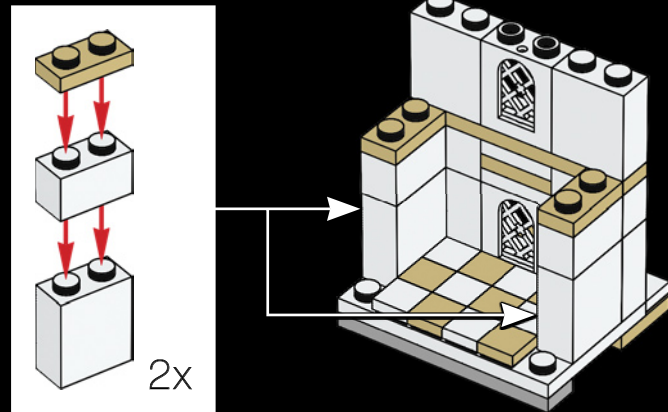



4x

61

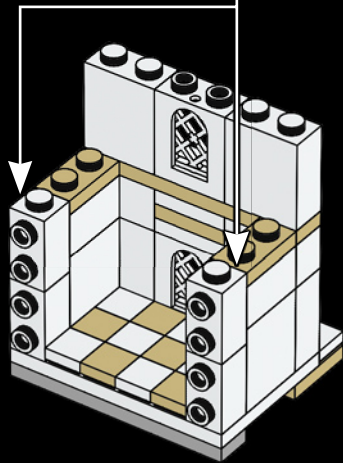
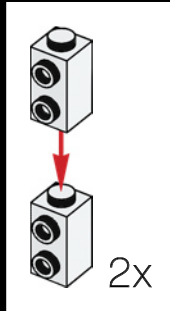

4x

62

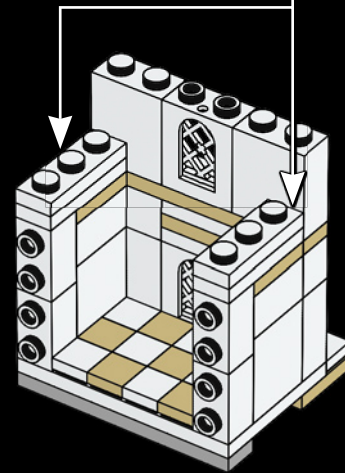
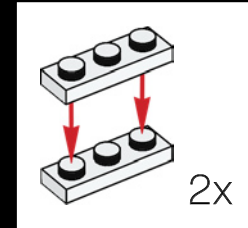

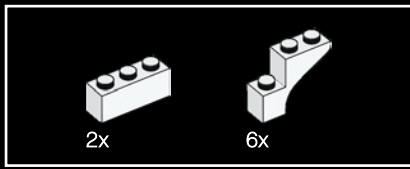

63

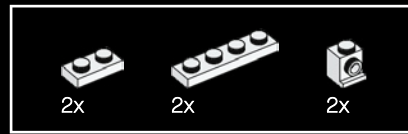
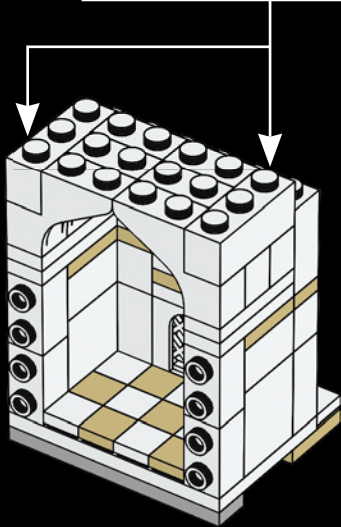
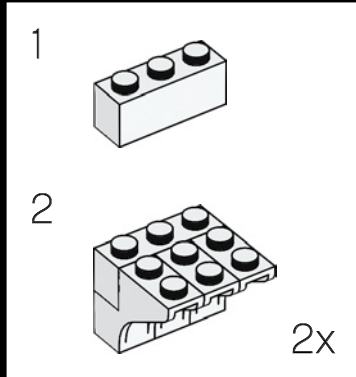

64

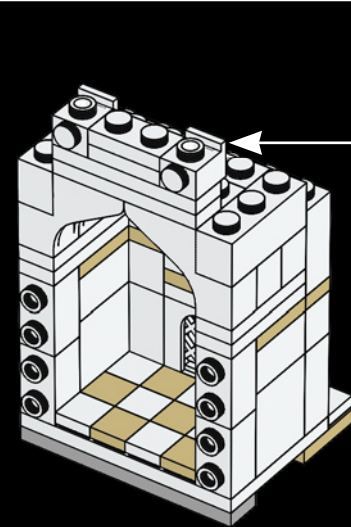
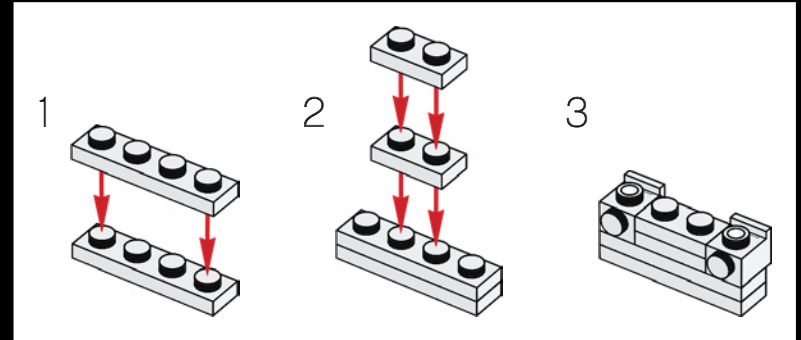

2x

65

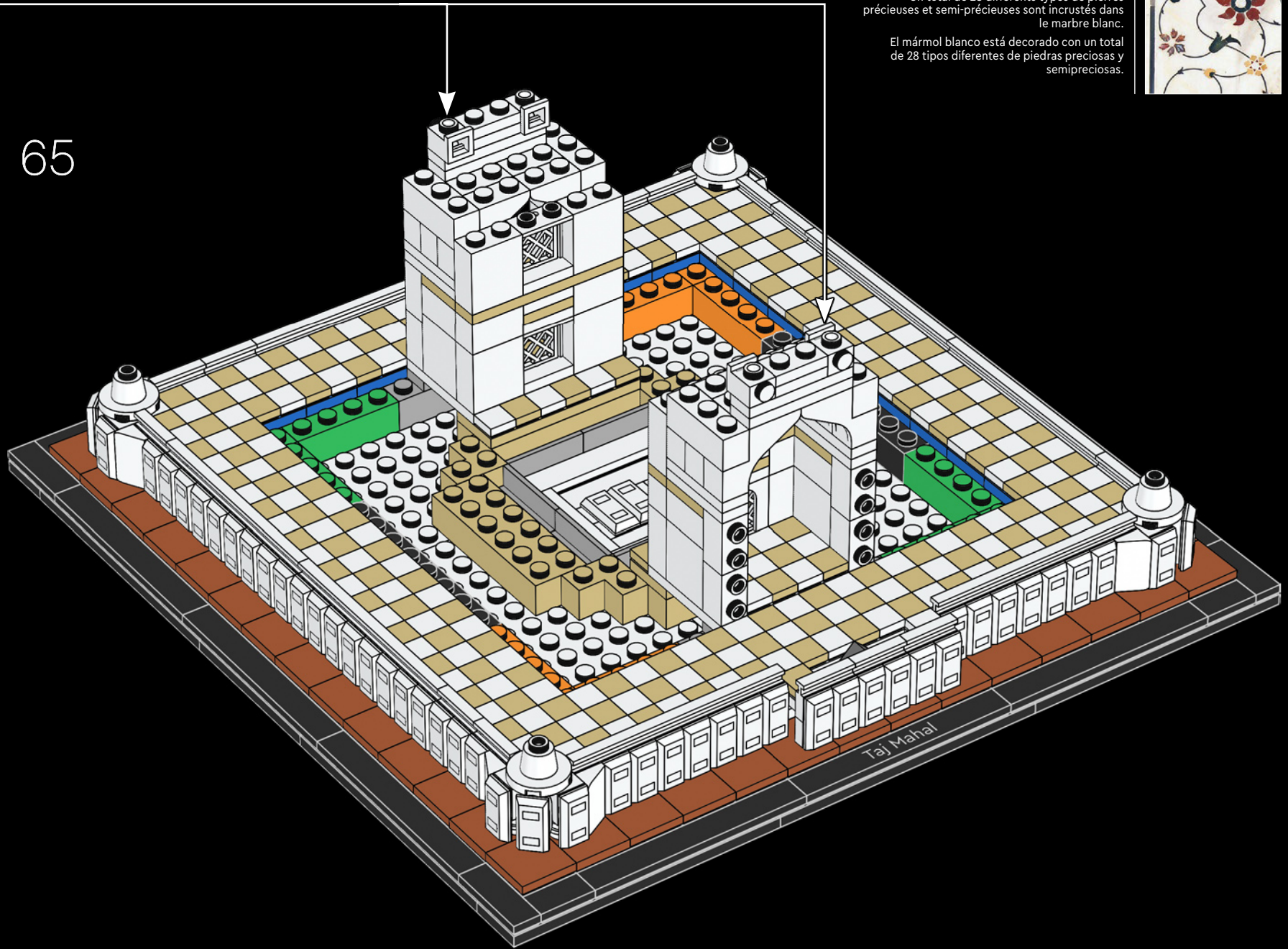

A total of 28 different types of precious and semiprecious jewels are set in the white marble.

Un total de 28 différents types de pierres précieuses et semi-précieuses sont incrustés dans le marbre blanc.

El mármol blanco está decorado con un total de 28 tipos diferentes de piedras preciosas y semipreciosas.



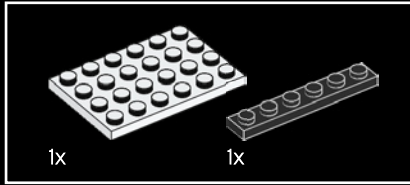
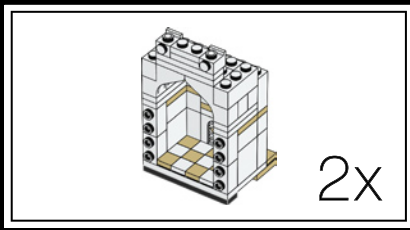

66

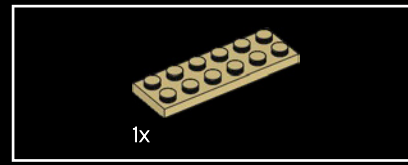
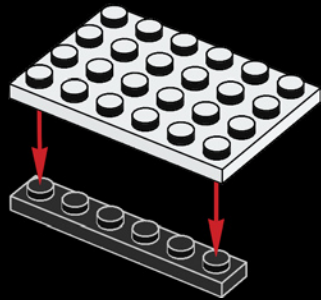

67

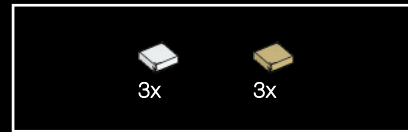
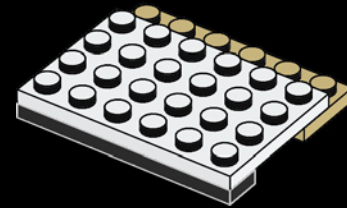

68

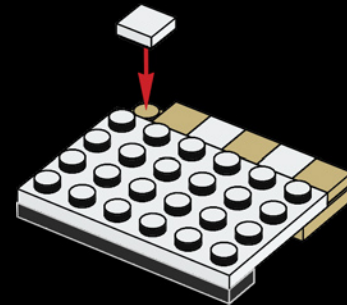

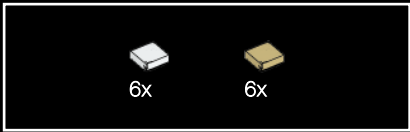

69

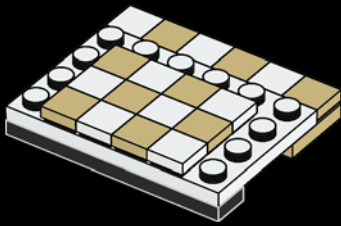

70

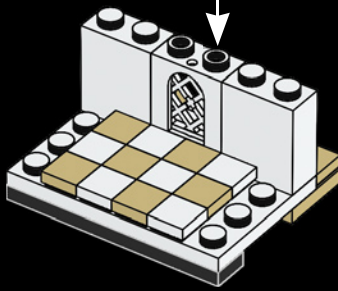
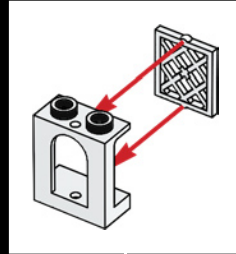



71

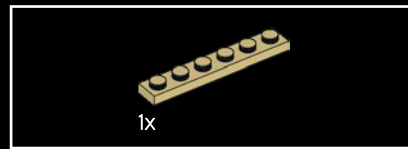
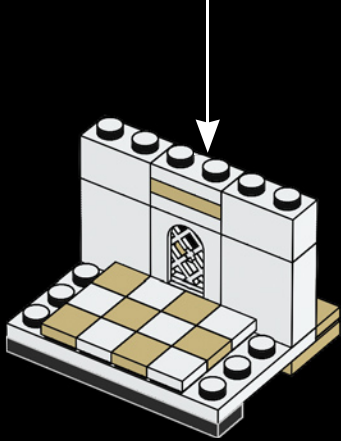
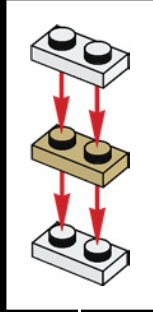

72

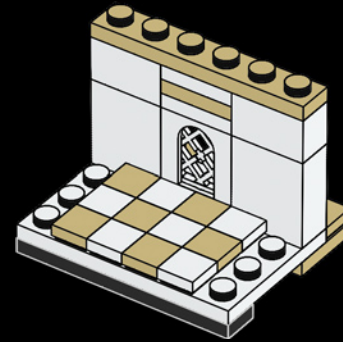

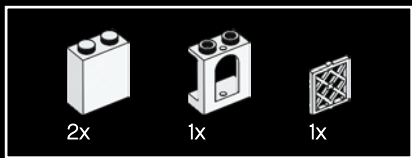

73

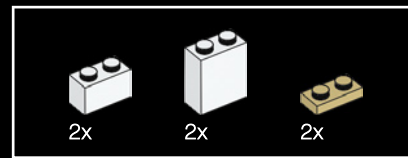
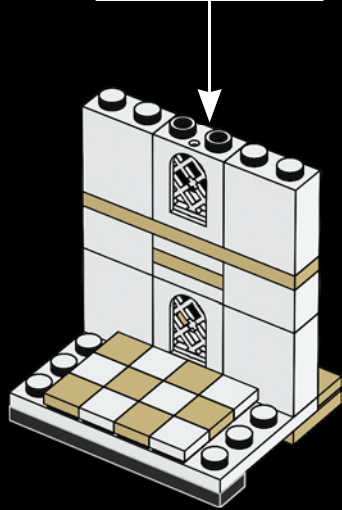
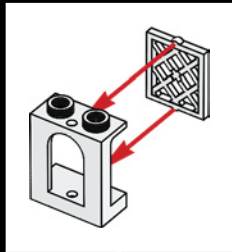

74

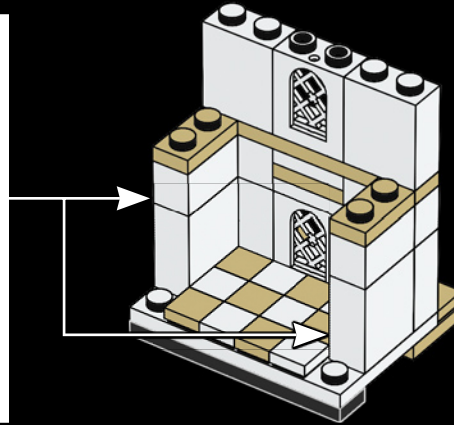
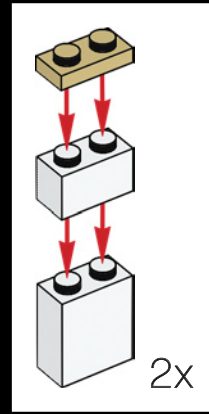

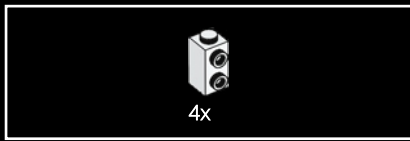

75

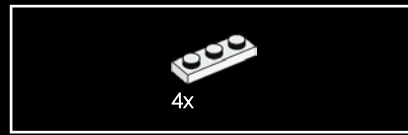
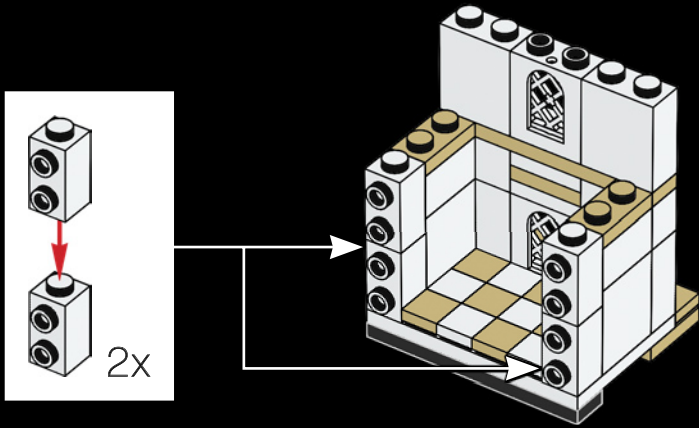

76

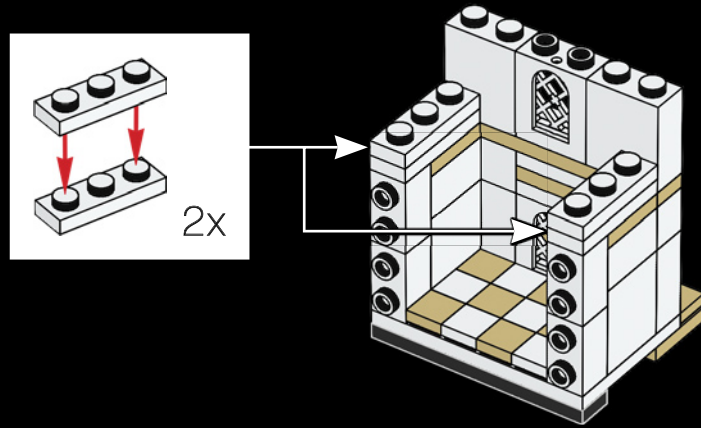

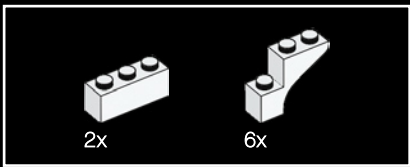

77

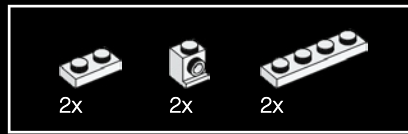
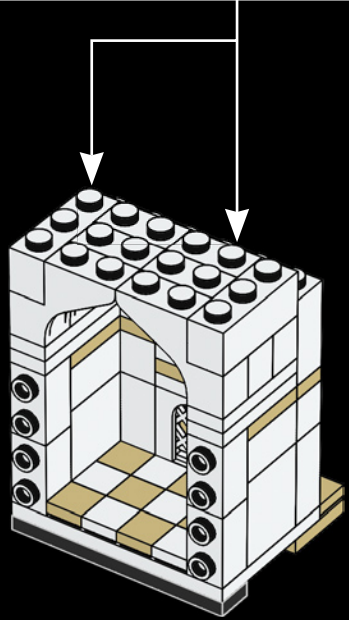
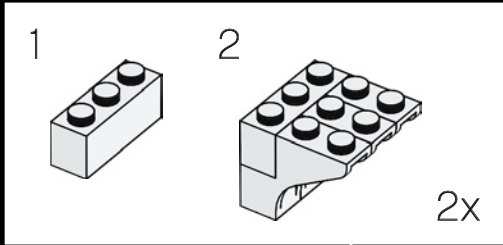

78

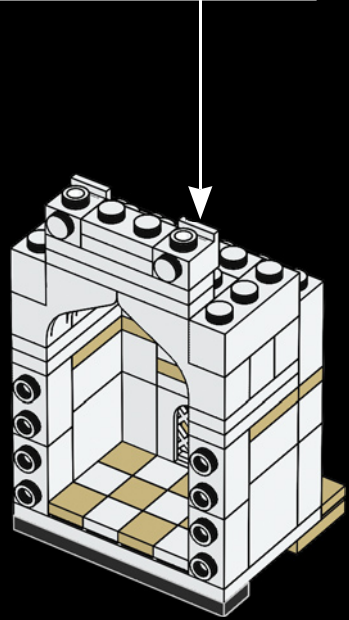
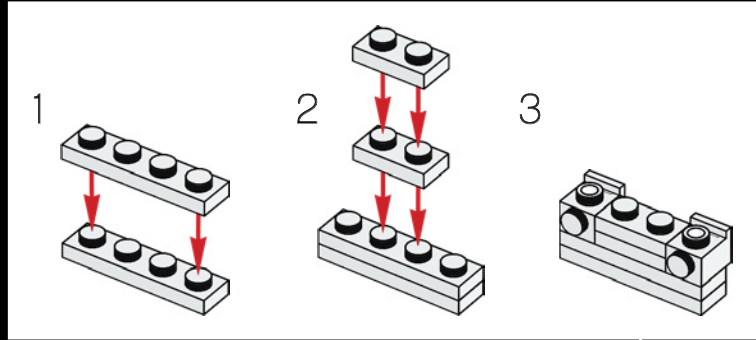

2x

79

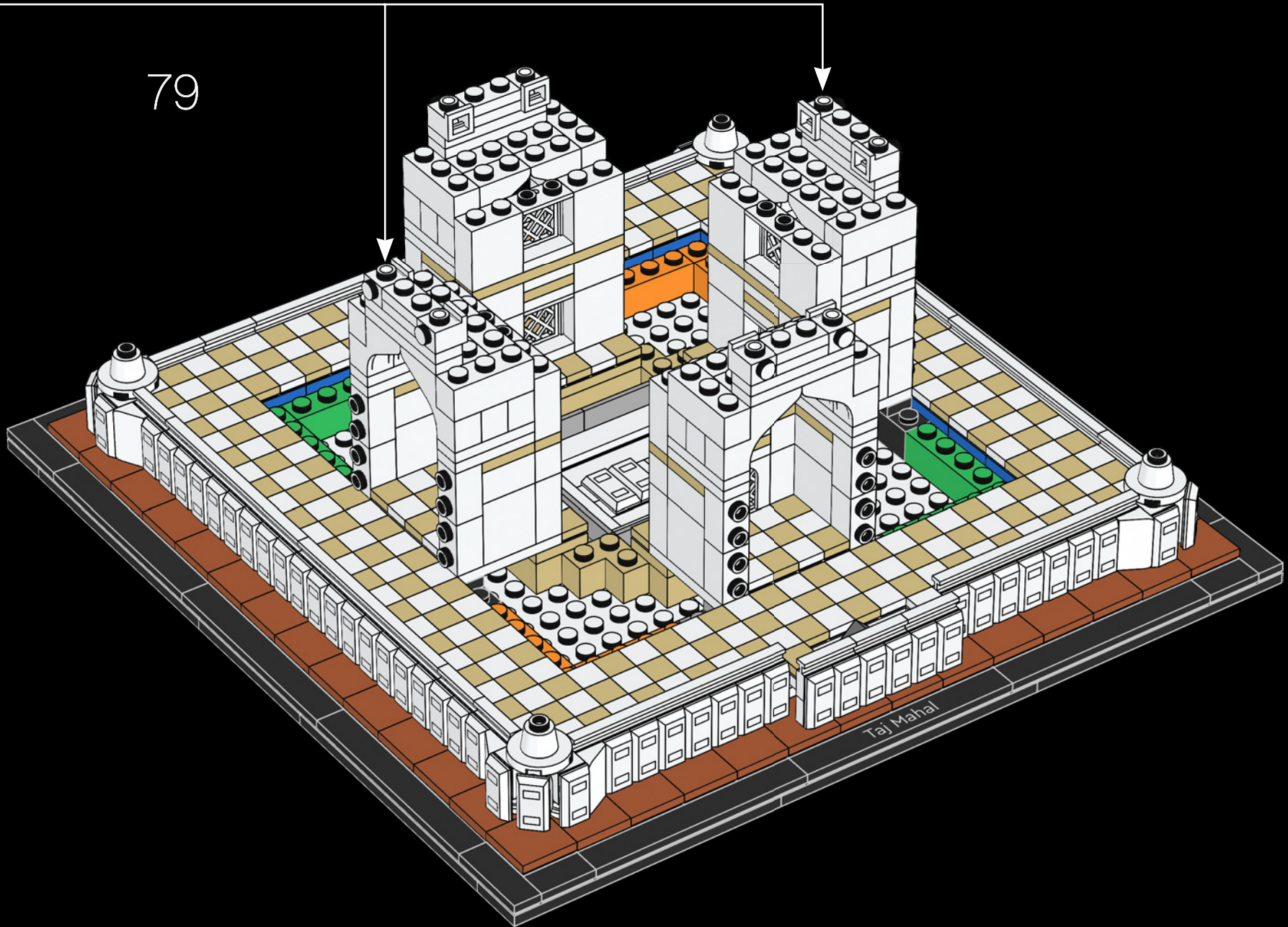

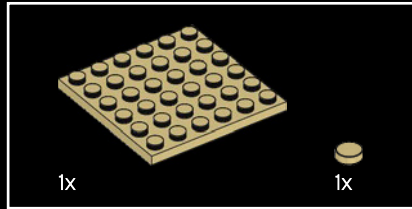
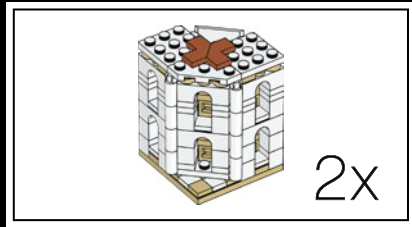
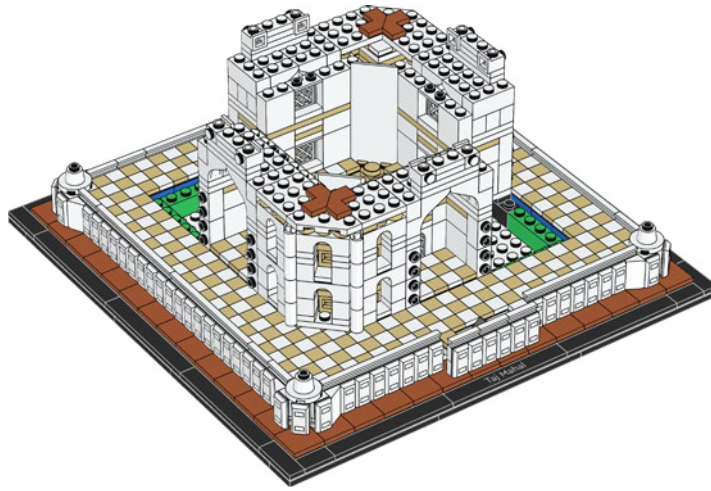
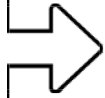

80

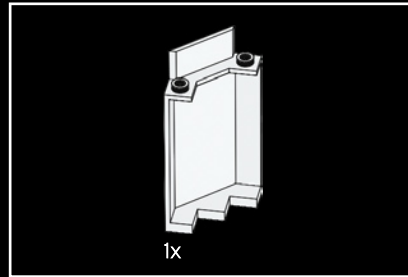
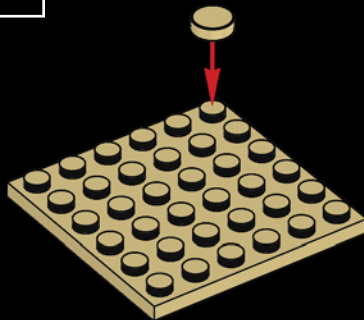

81

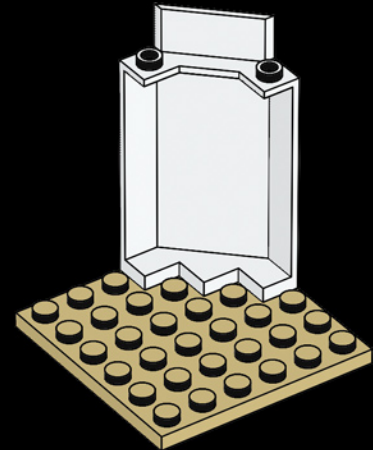



82

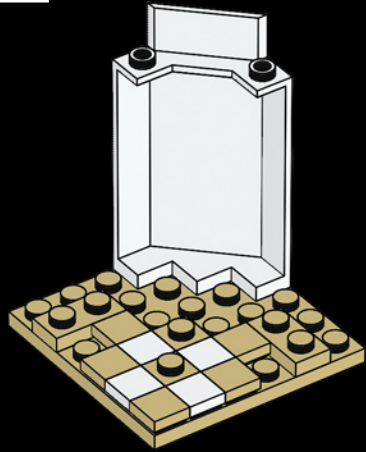

83

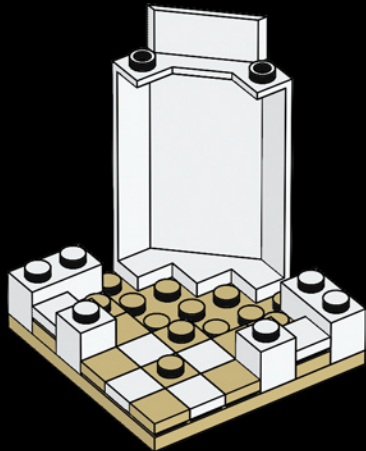

84

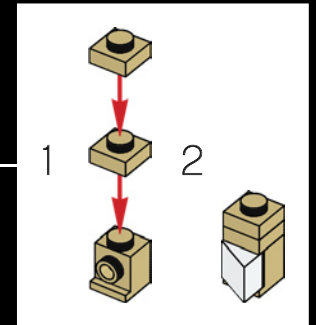
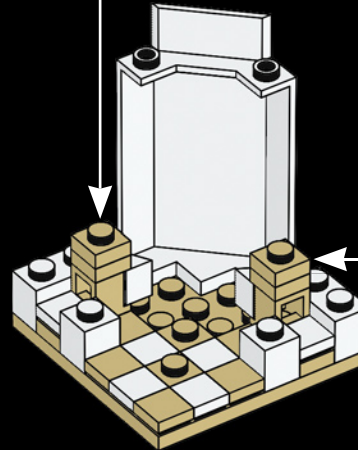
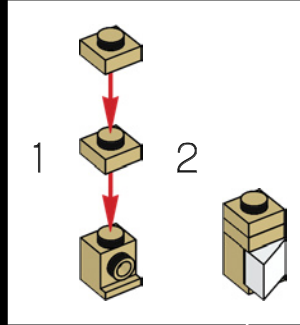

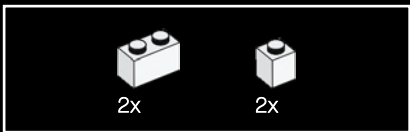

85

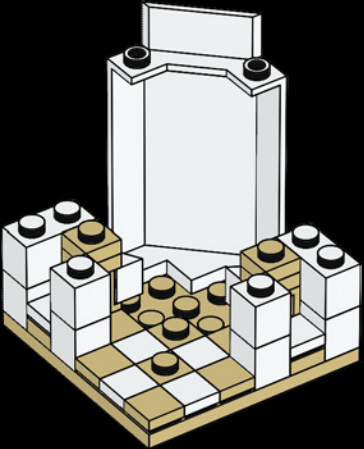

86

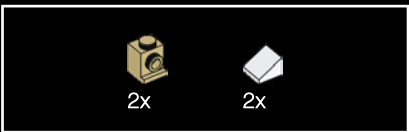
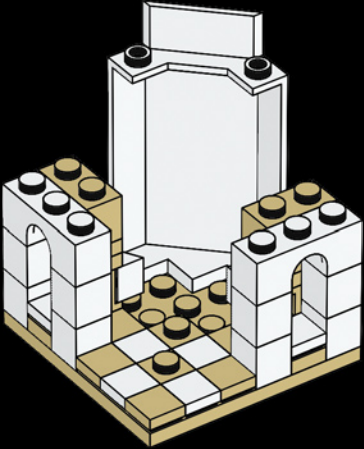

87

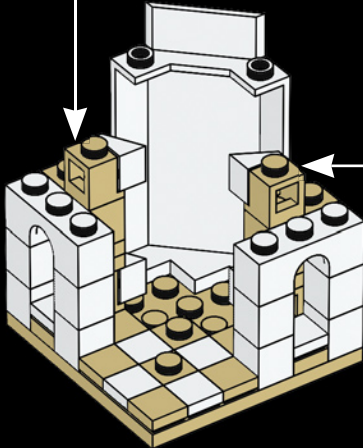
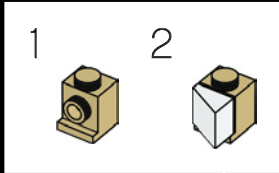
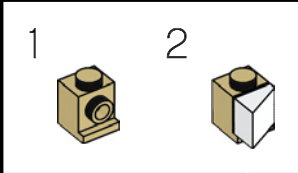



88

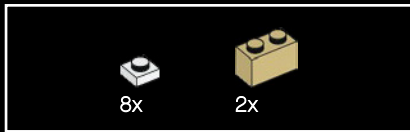
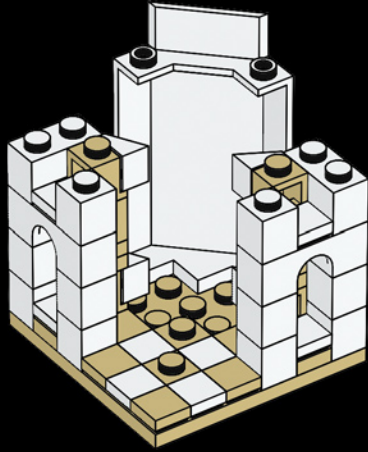

89

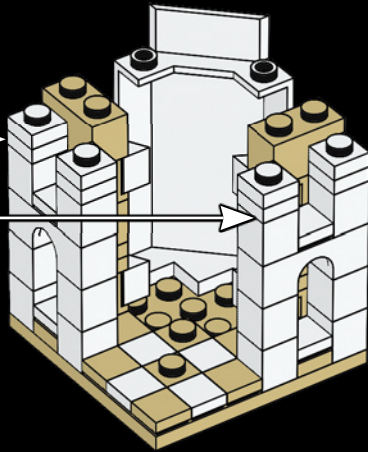
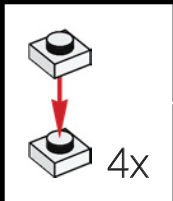

90

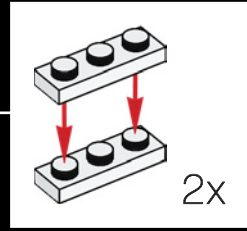
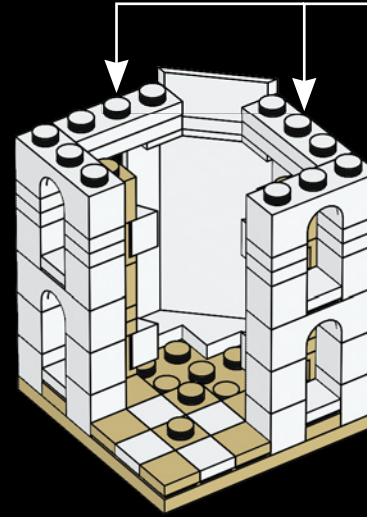

91

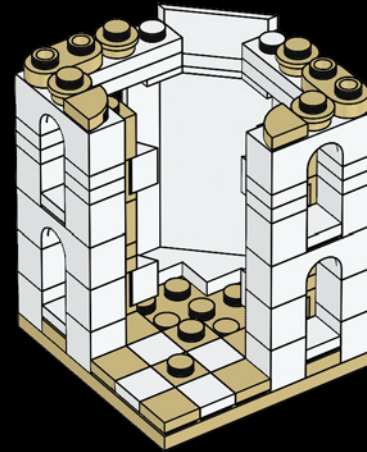

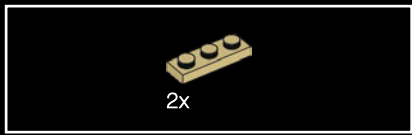

92

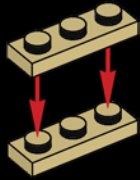

93

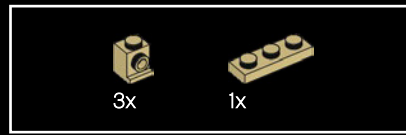
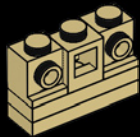

94

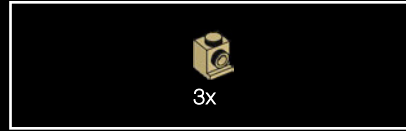
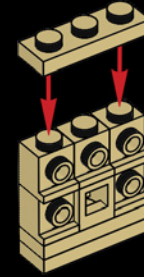

95

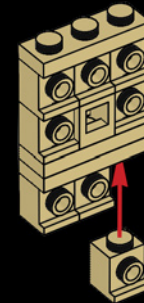

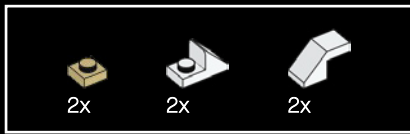

96

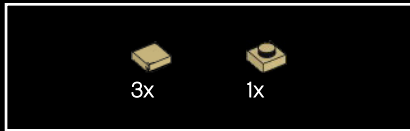
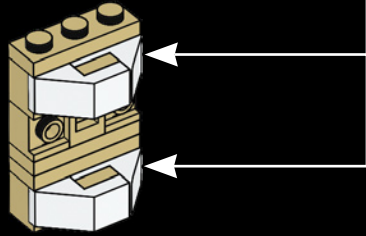
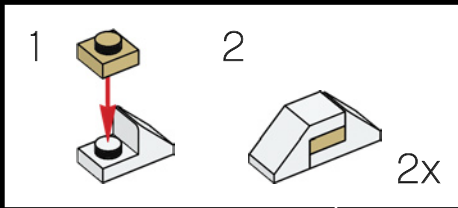

97

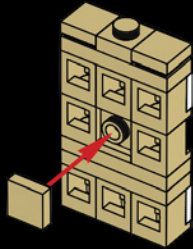

98

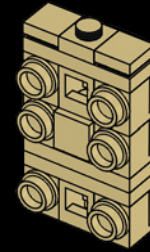

99

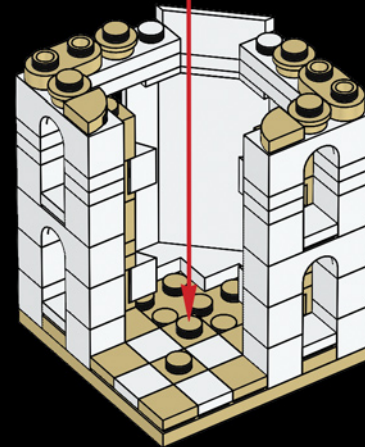
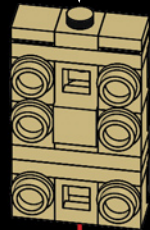

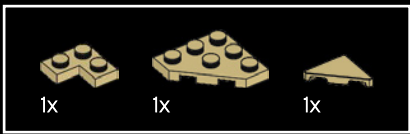

100

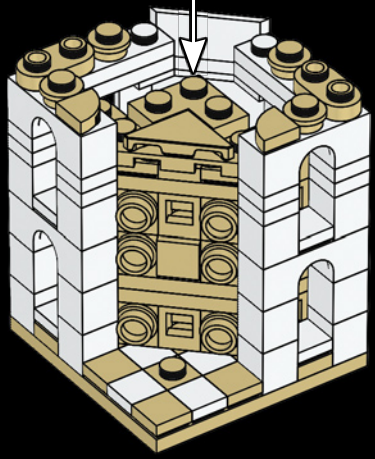
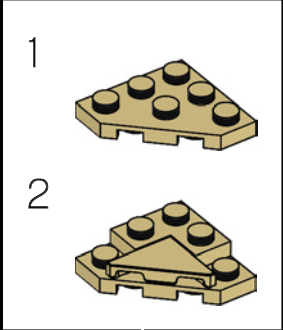

The Taj Mahal attracts 7-8 million visitors a year.
Le Taj Mahal attire de 7 à 8 millions de visiteurs par an.
El Taj Mahal atrae de 7 a 8 millones de visitantes al año.





101

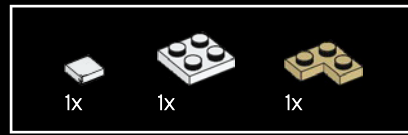
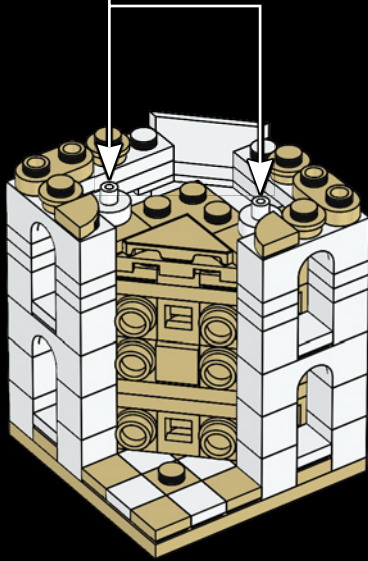
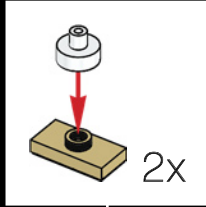

102

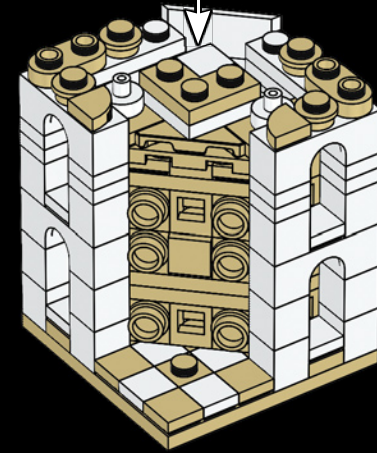
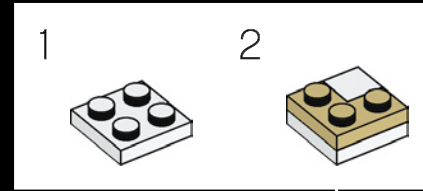

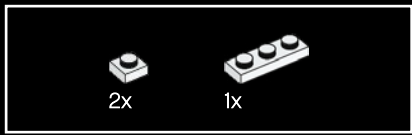

103

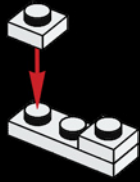

104

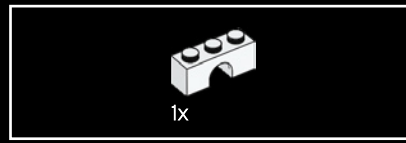
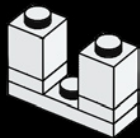

105



106

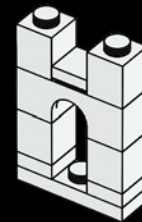



107

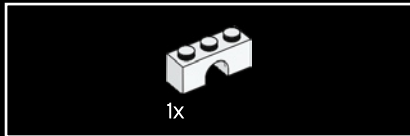
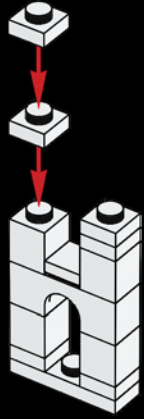

108

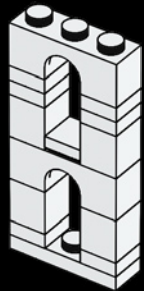

109

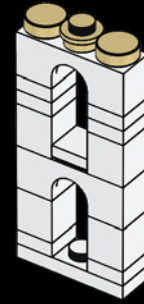

110

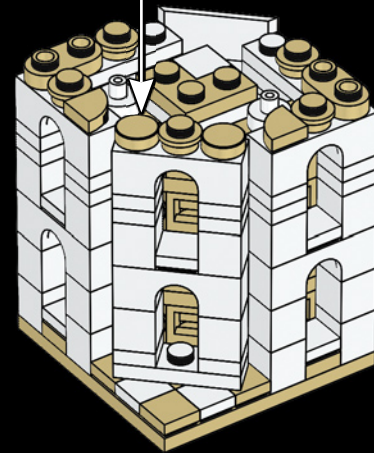

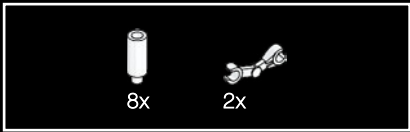

111

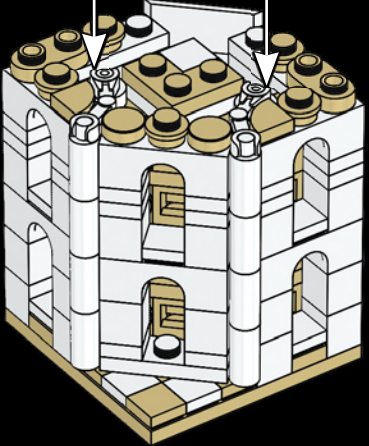
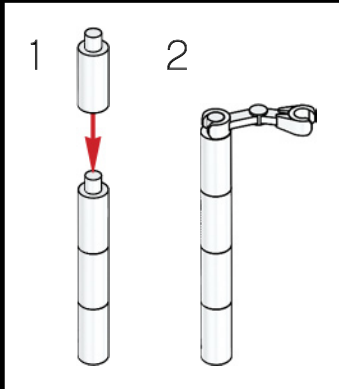
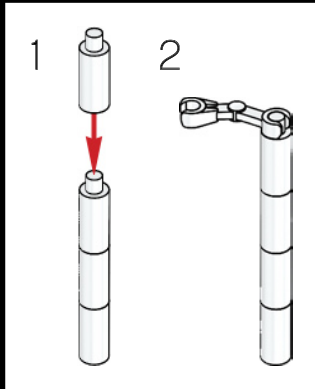

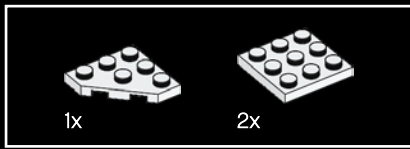

112

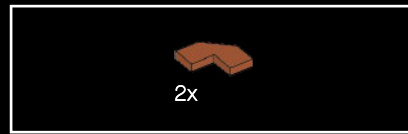
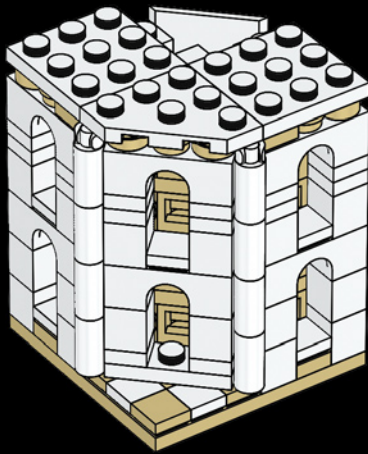

113

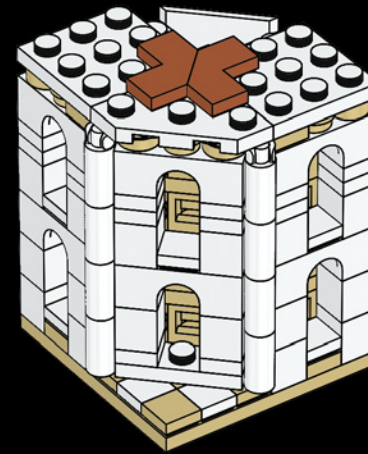

2x

114

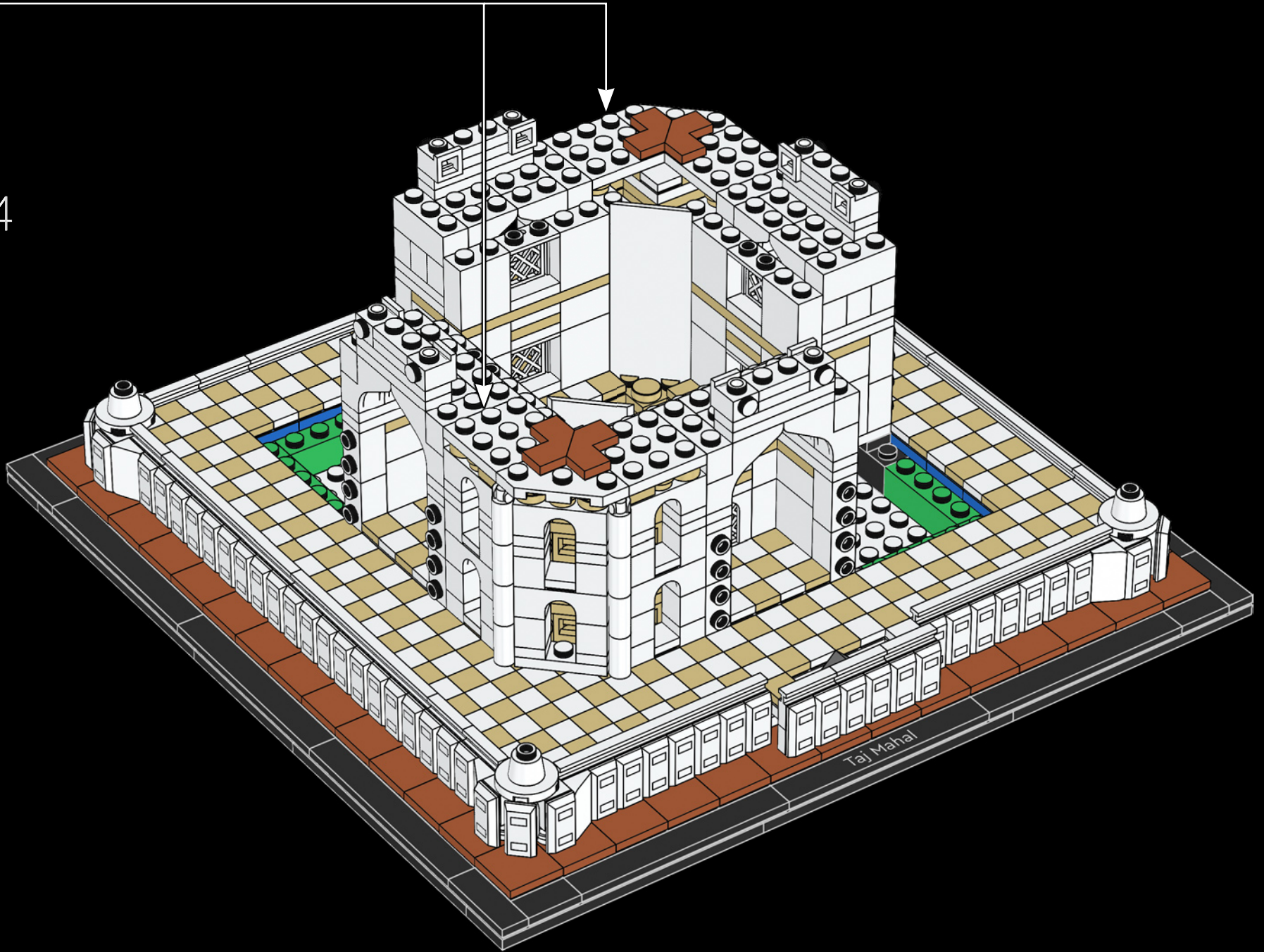

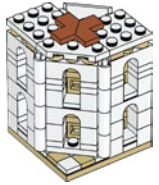
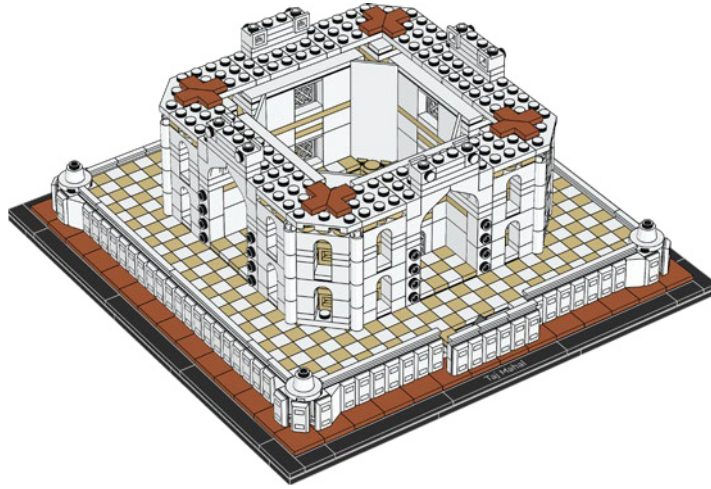
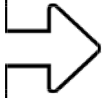

2x

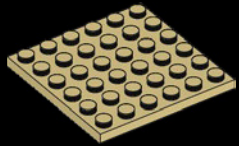

1x



1x

115

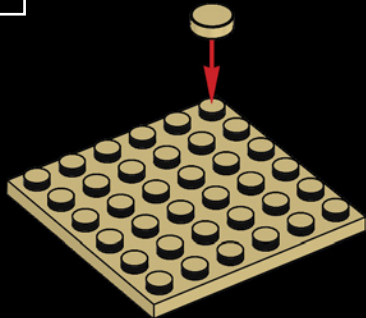

1x

116

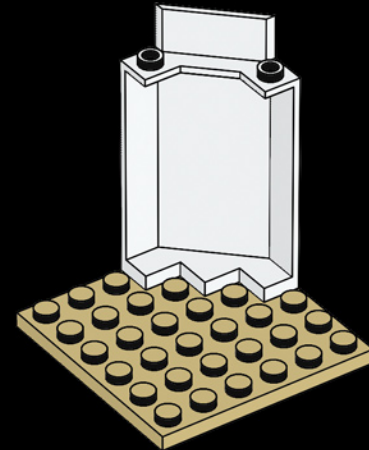

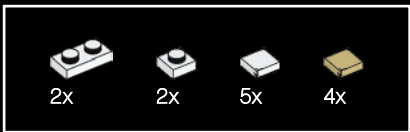

117

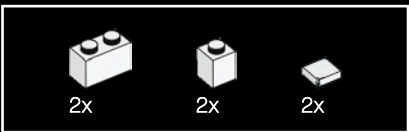
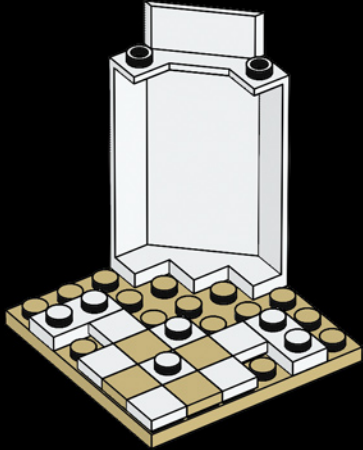

118

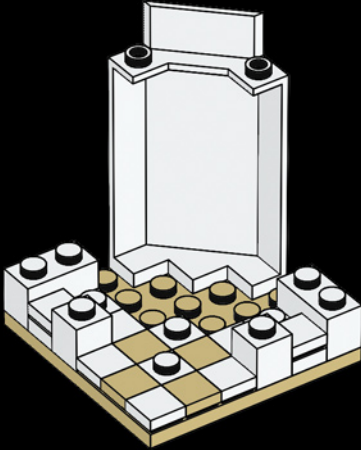



119

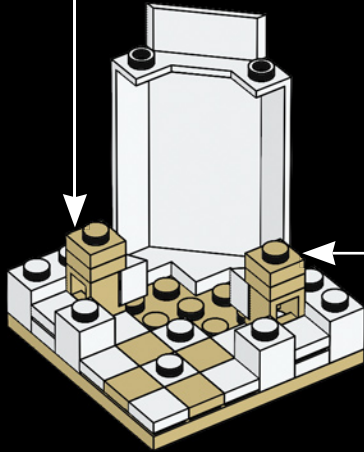
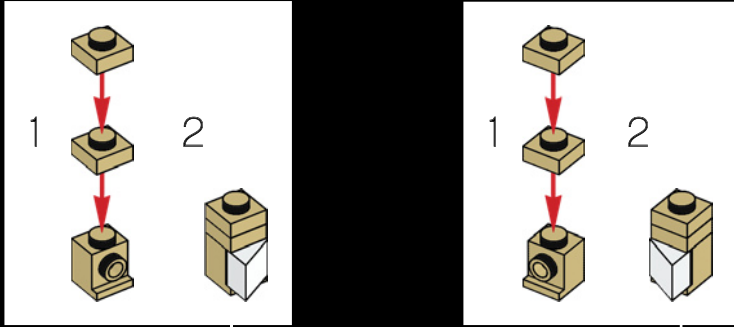

120

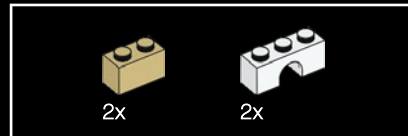
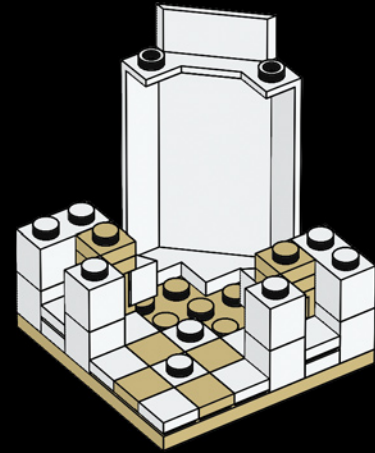

121

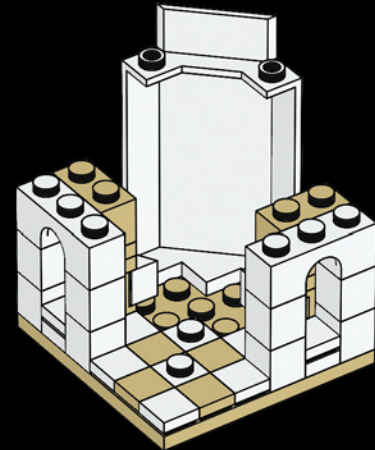

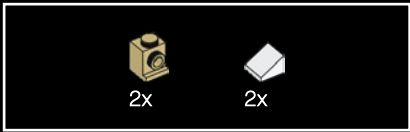

122

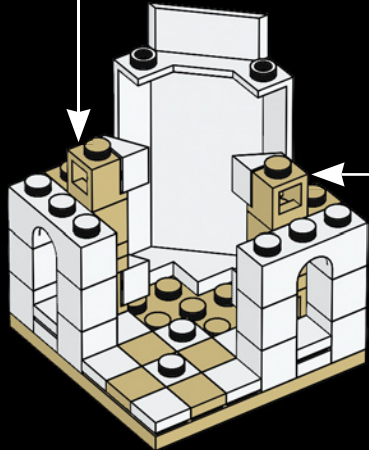
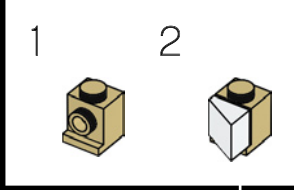
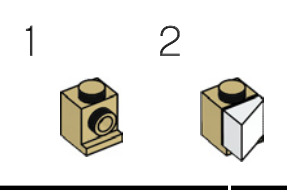

123

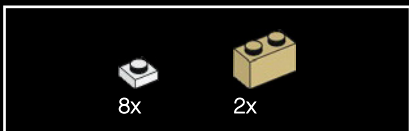
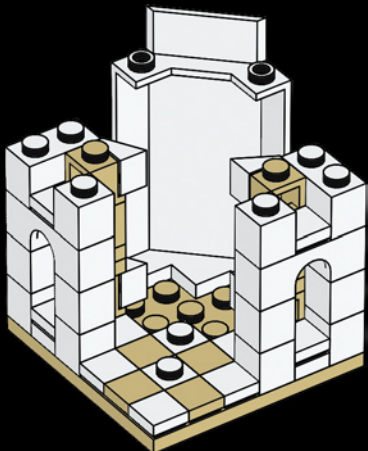

124

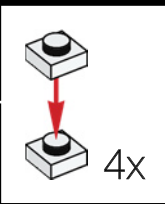
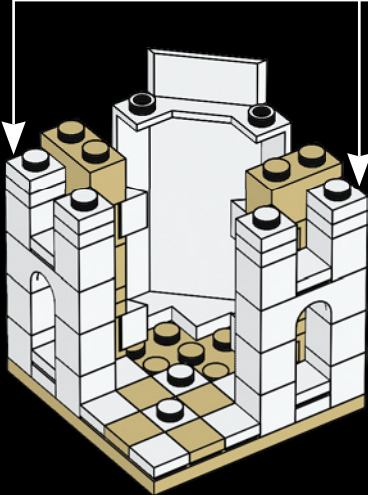

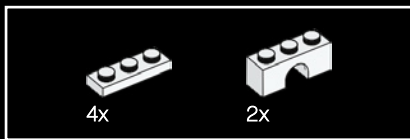

125

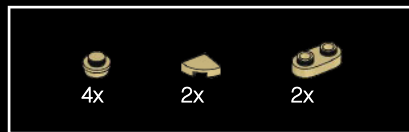
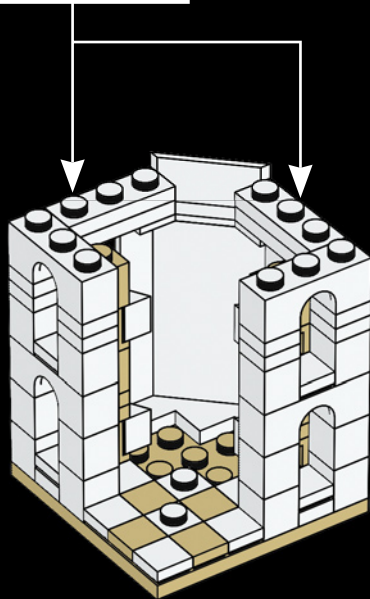
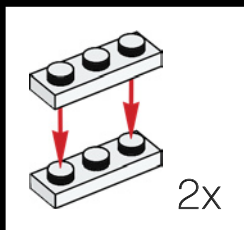

126

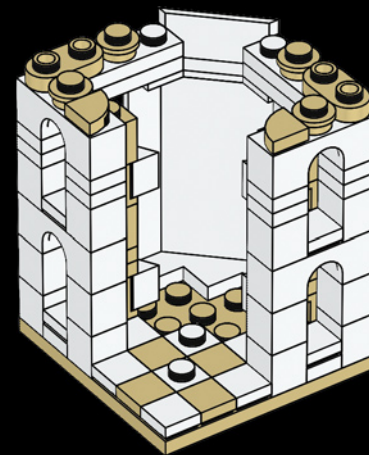



127

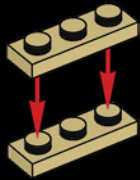

128

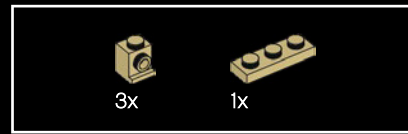
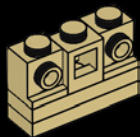

129

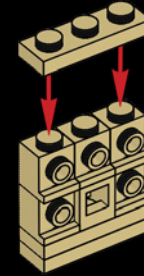

130

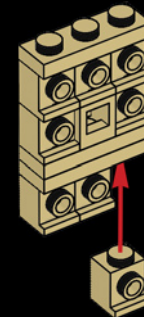



131

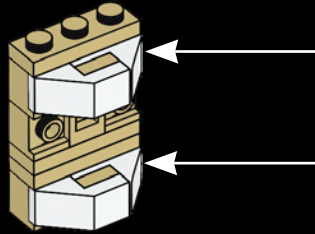
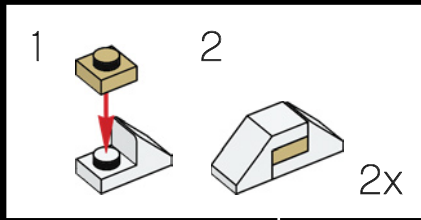

132

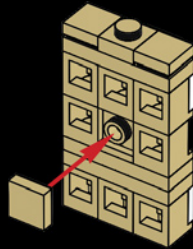

133

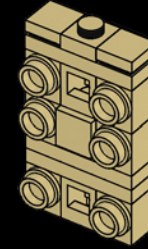

134

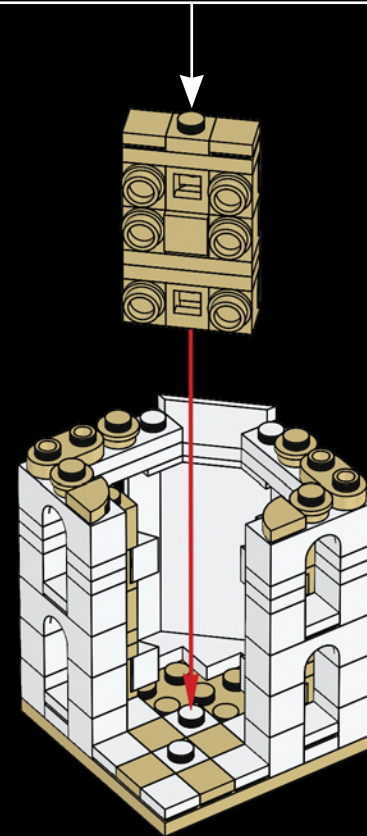

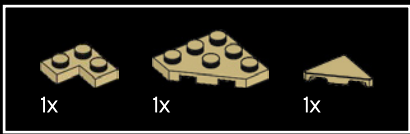

135

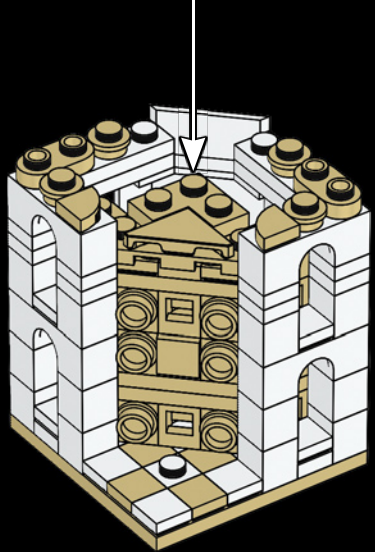
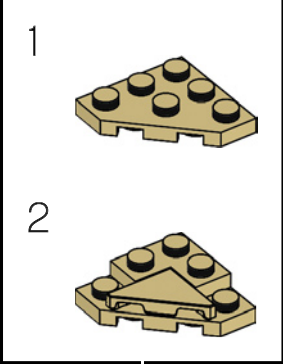



136

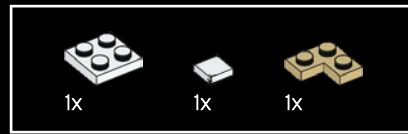
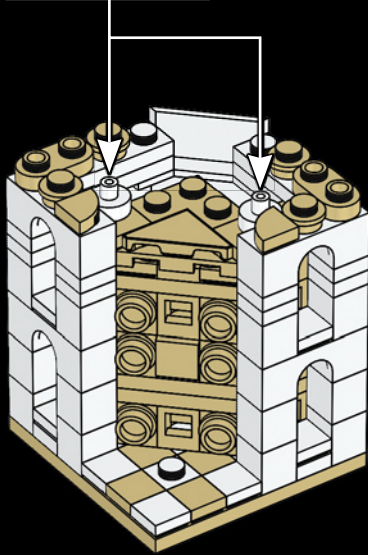
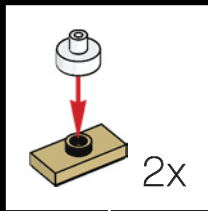

137

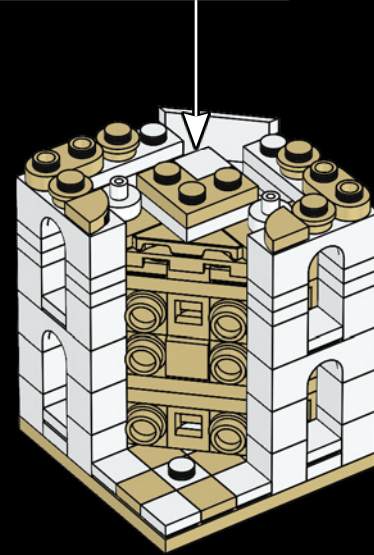
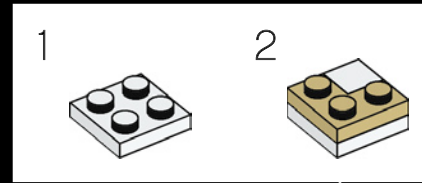

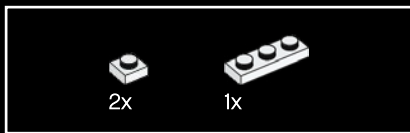

138

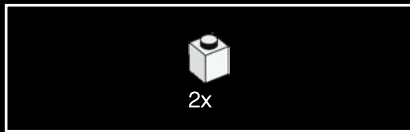
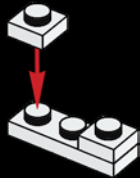

139

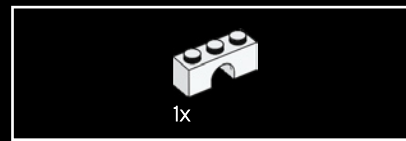

140



141





142

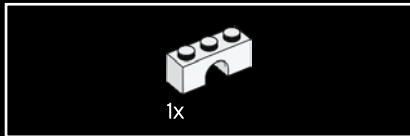
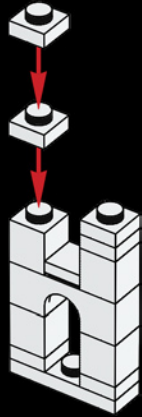

143

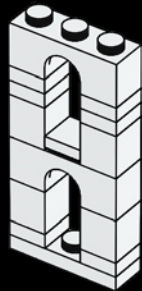

144



145

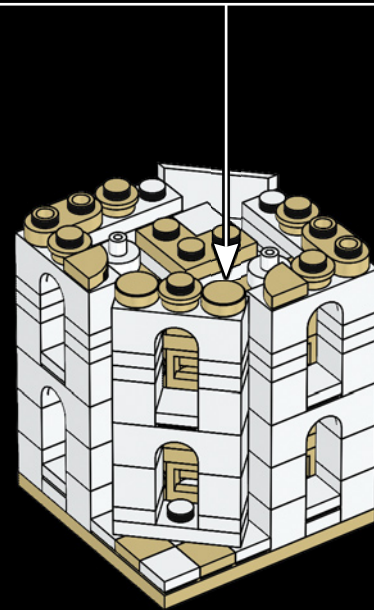

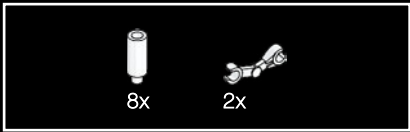

146

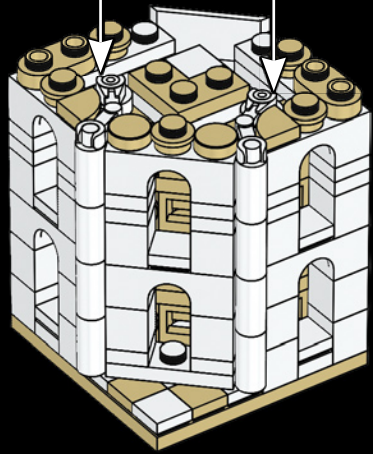
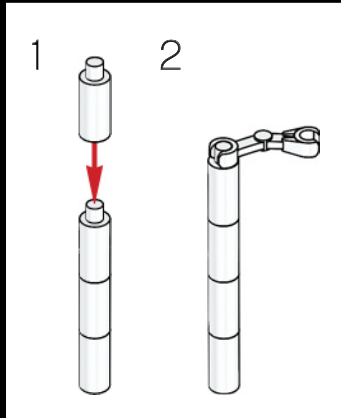
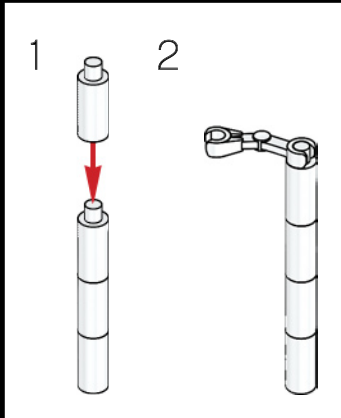

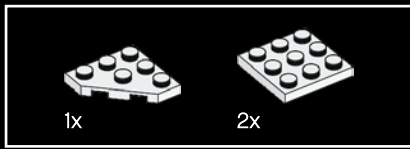

147

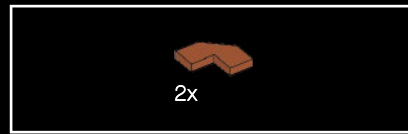
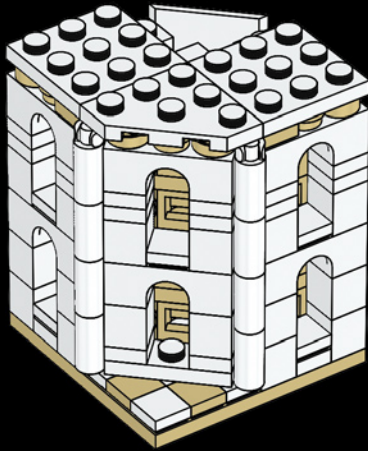

148

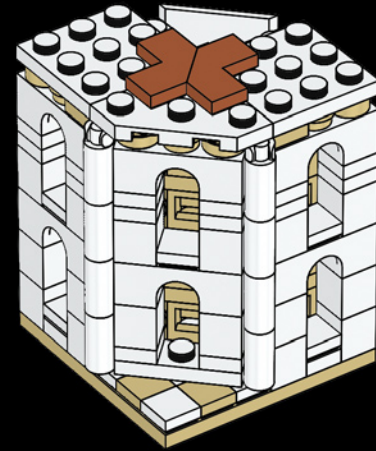

2x

149

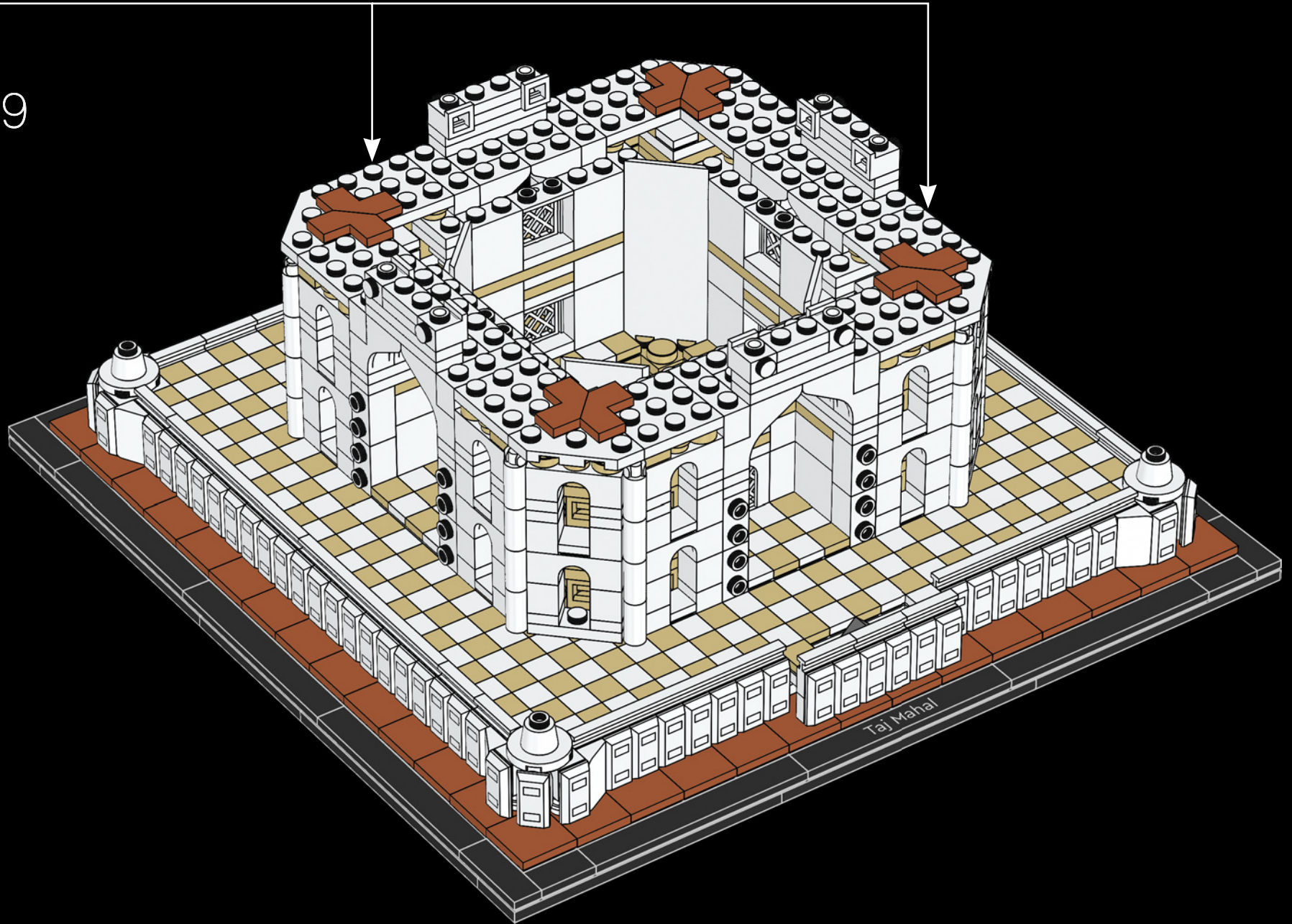

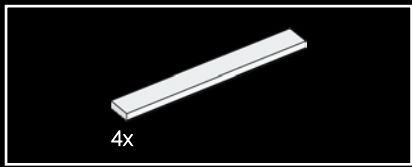

150

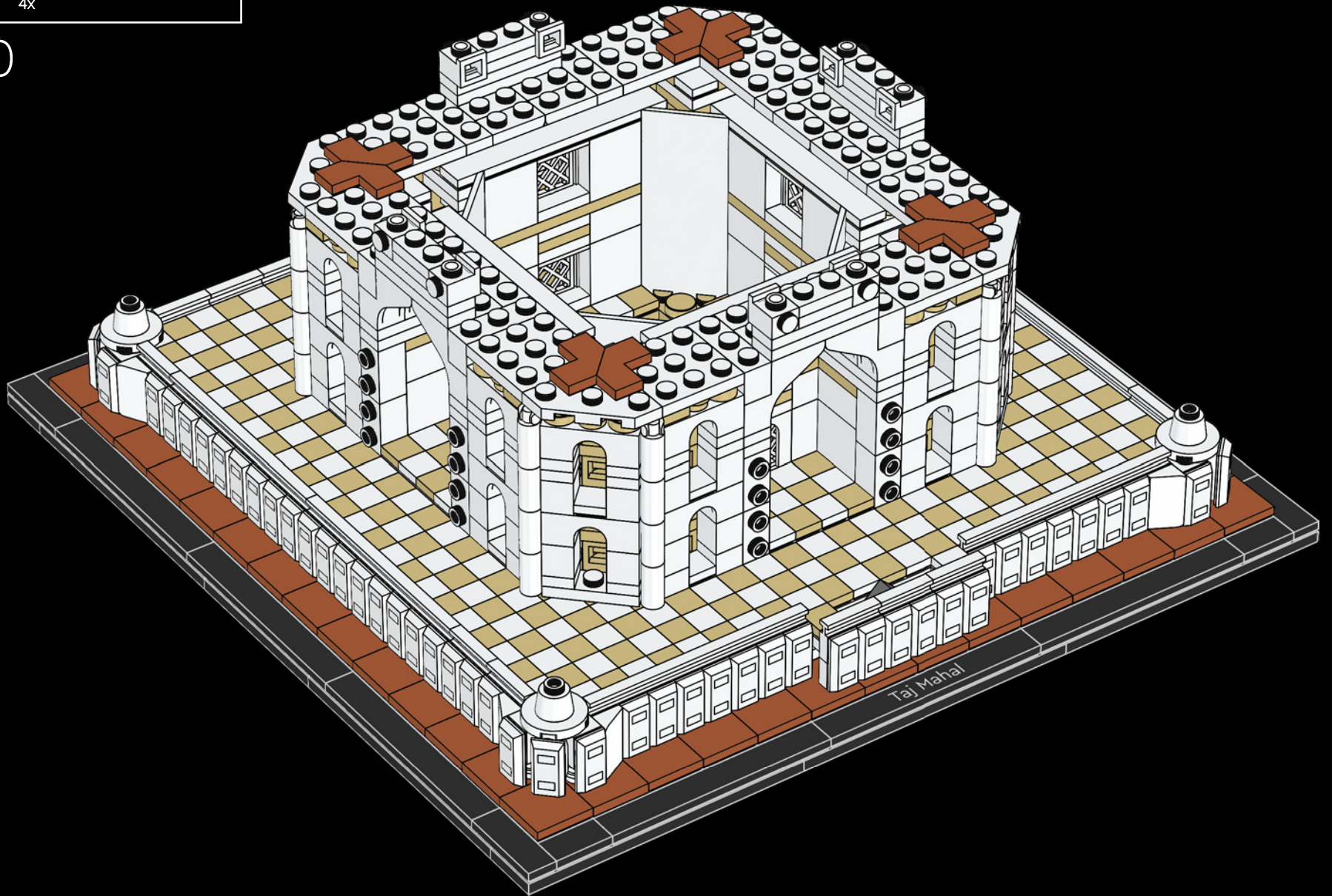

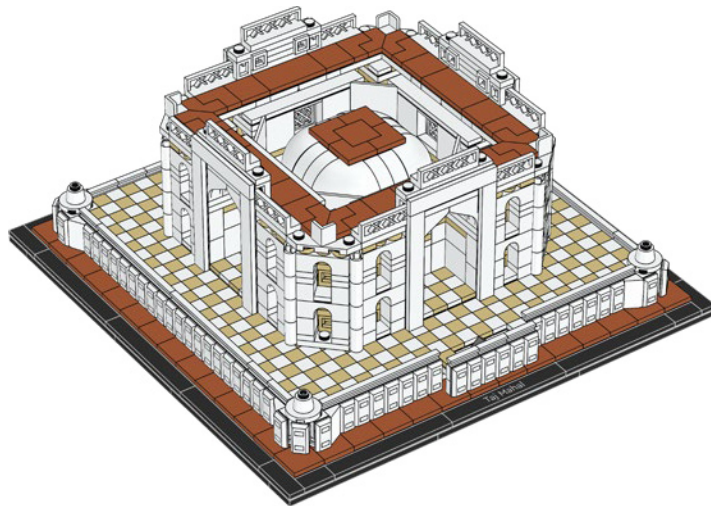
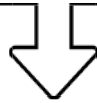

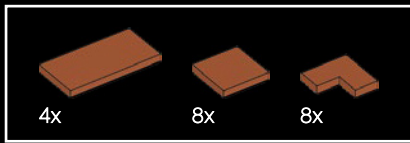

151

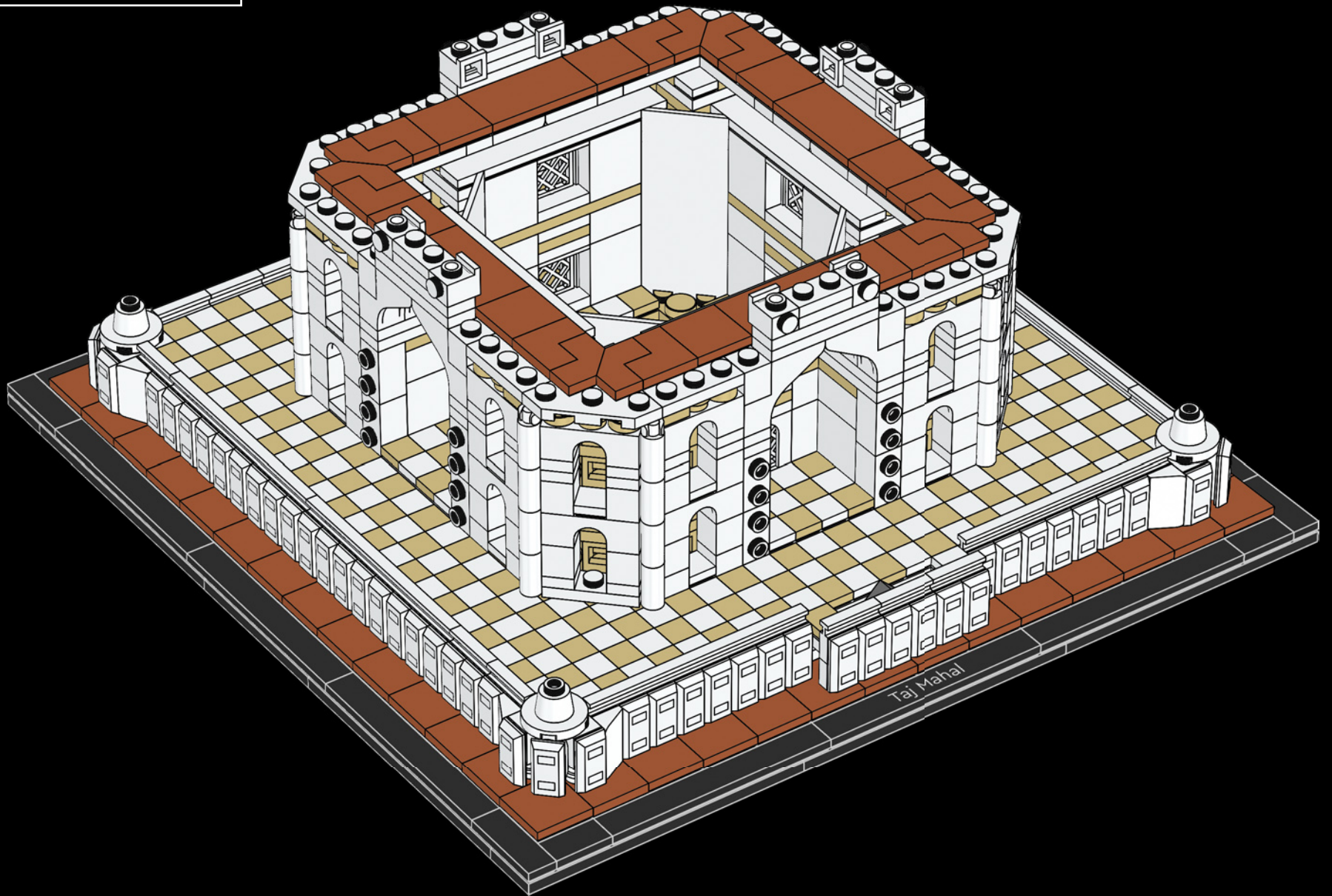

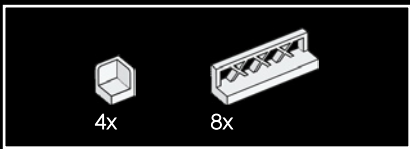

152

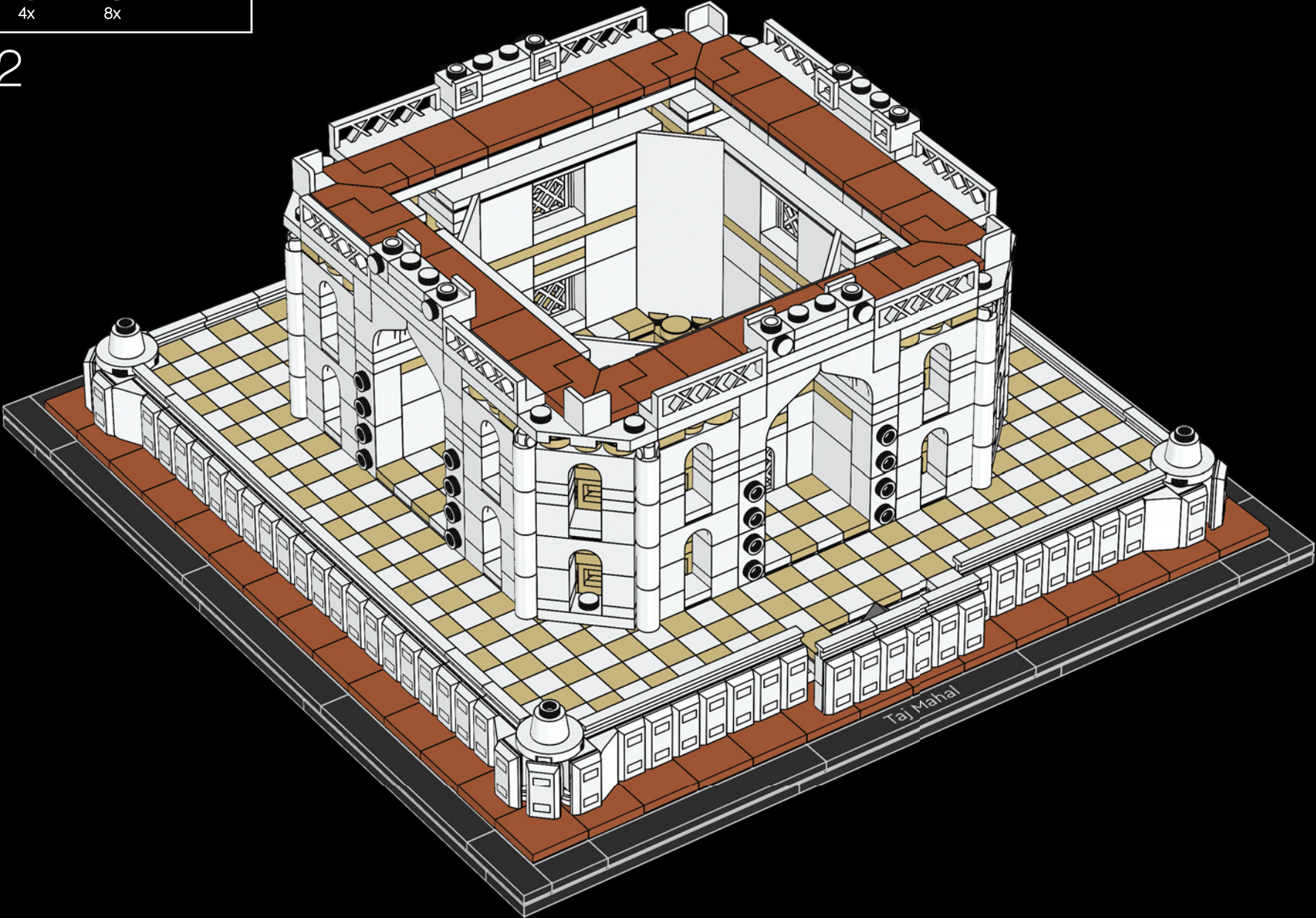

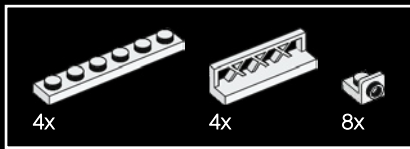

153

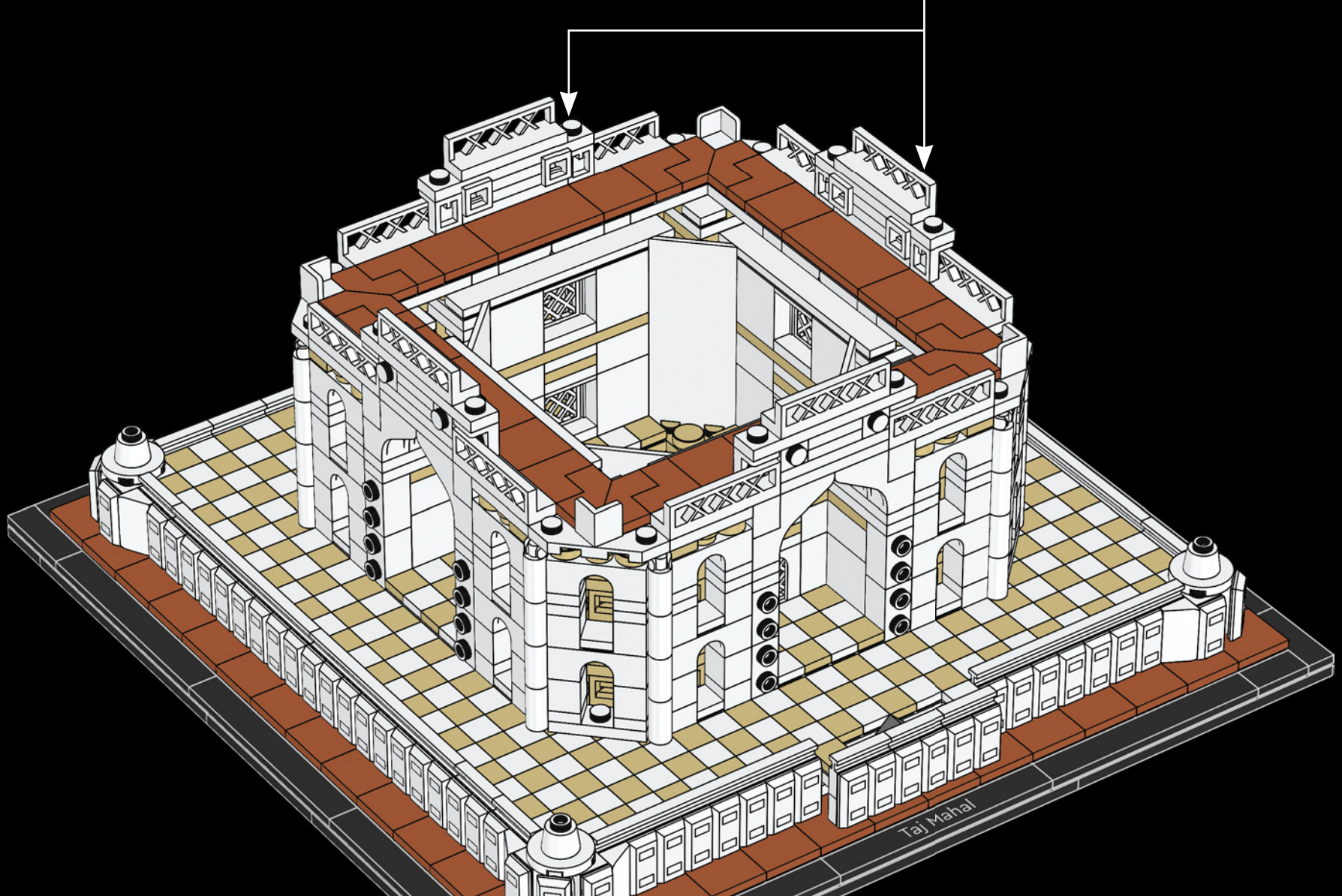
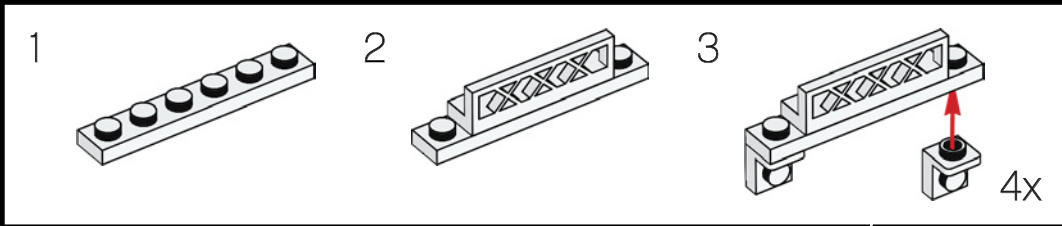

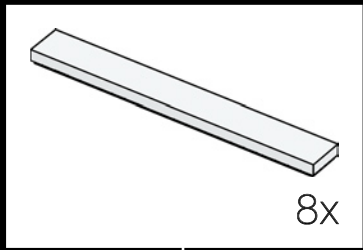
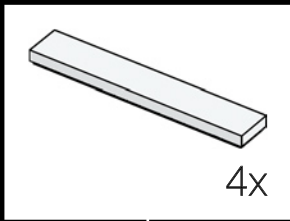
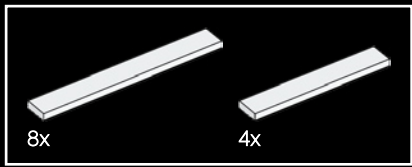

154

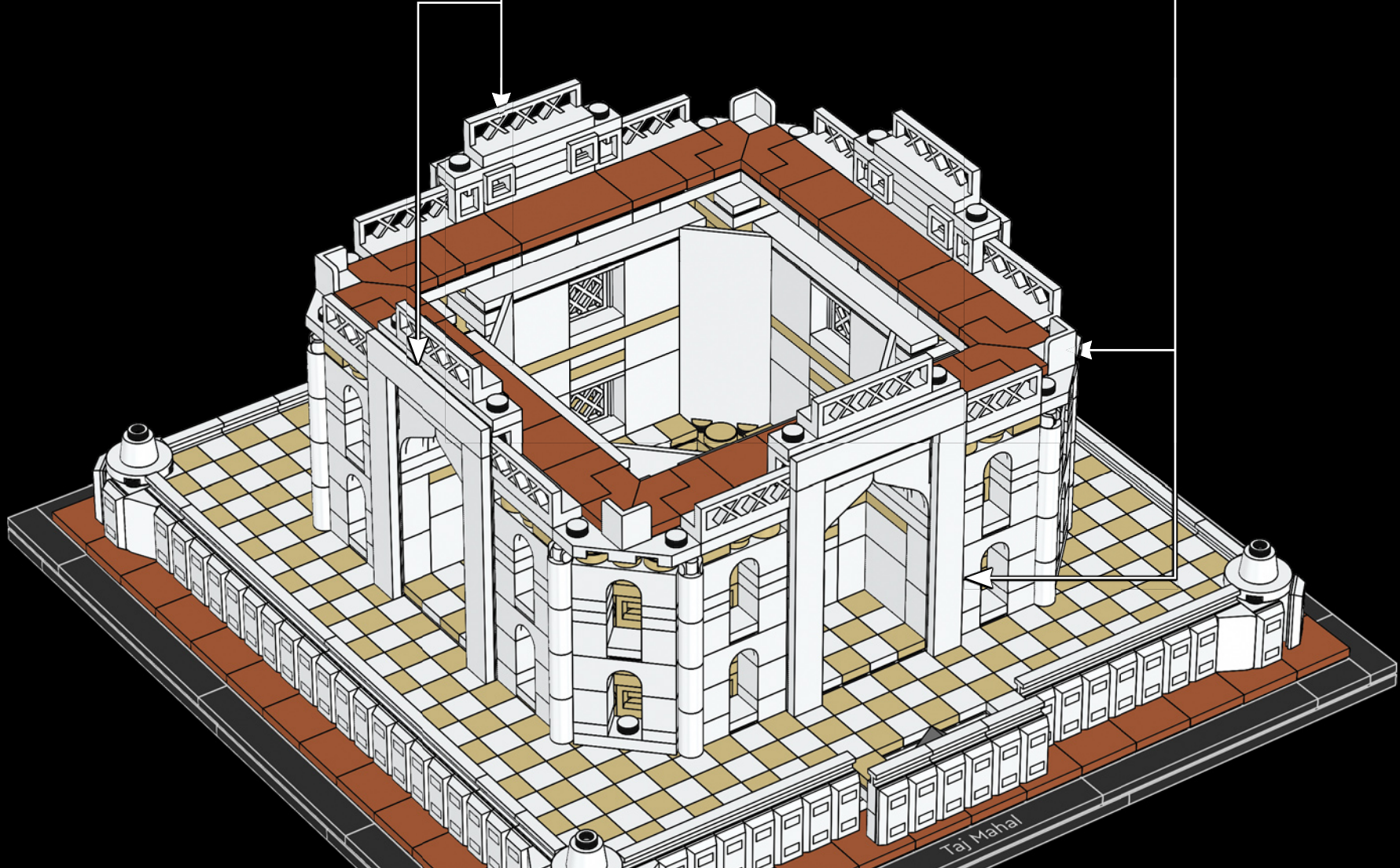

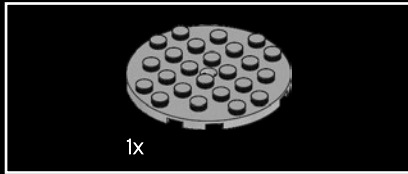
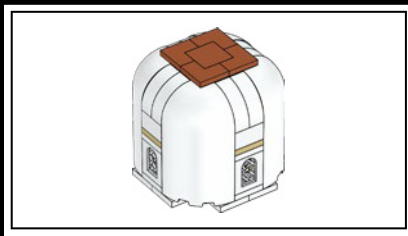

155

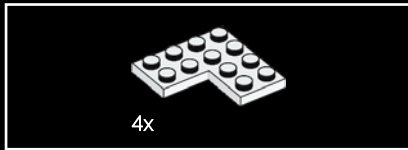
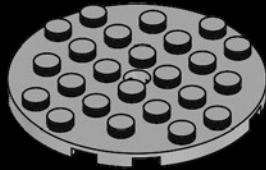

156

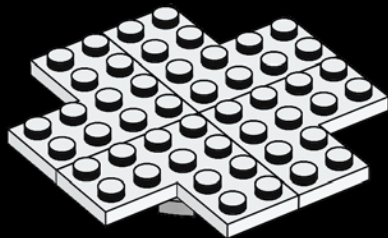

157

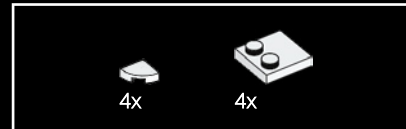
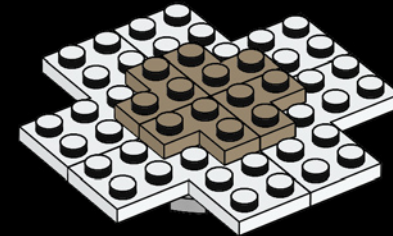

158

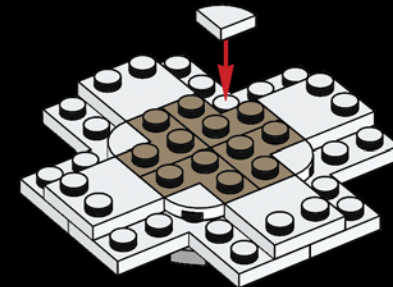



159

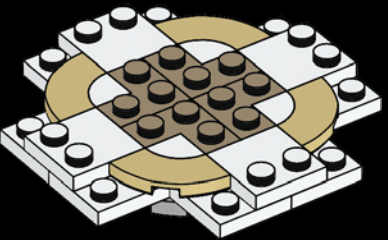

160

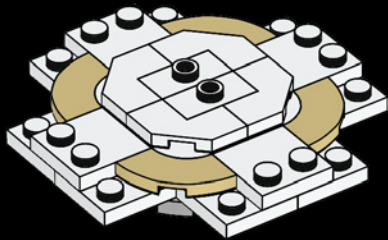

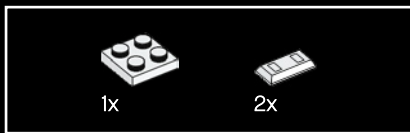

161

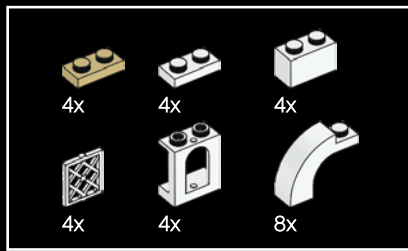
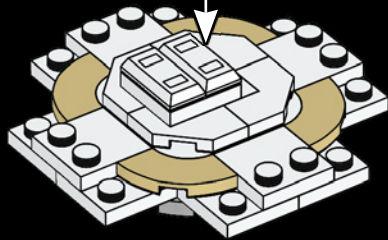
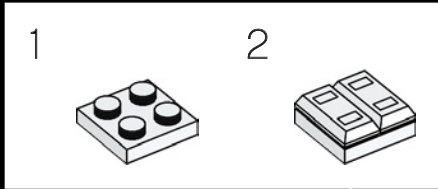

162

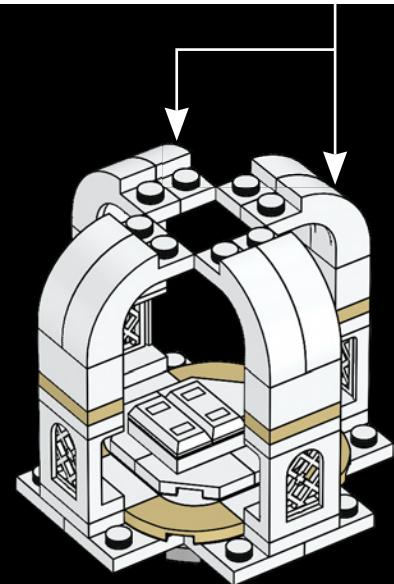
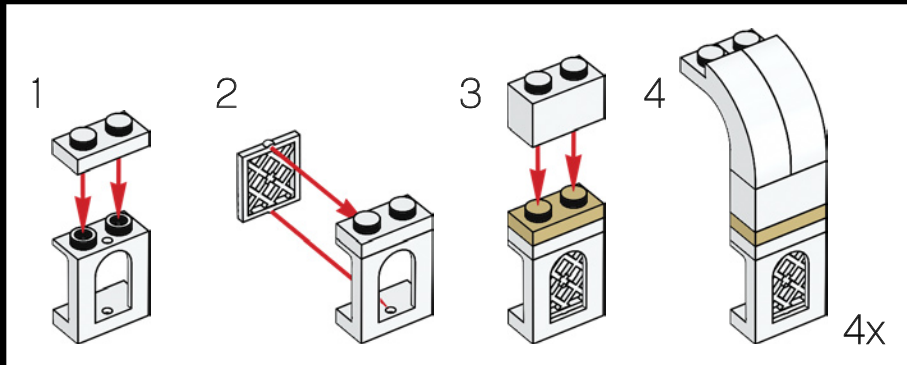

Shah Jahan's cenotaph is beside Mumtaz's and is the only visible asymmetric element in the entire complex.

Le cénotaphe de Shâh Jahân se trouve à côté de celui de Mumtaz et est le seul élément asymétrique visible dans l'ensemble du complexe.

El cenotafio de Shah Jahan está junto al de Mumtaz y es el único elemento asimétrico visible en todo el complejo.



163

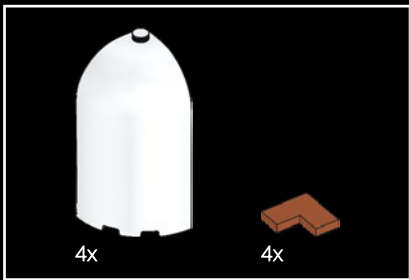
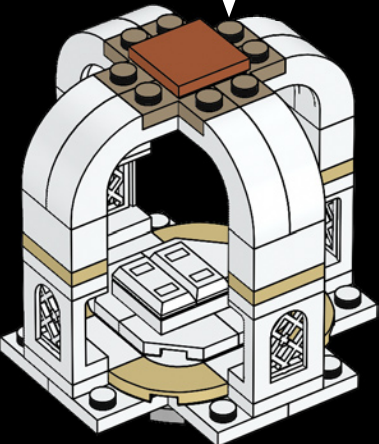
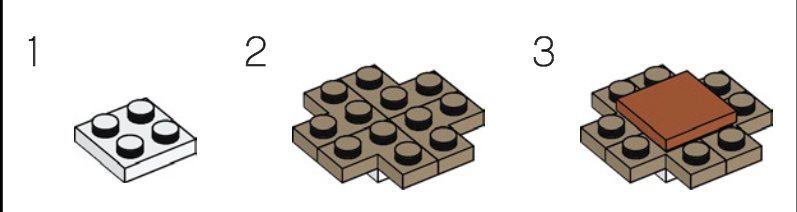

164

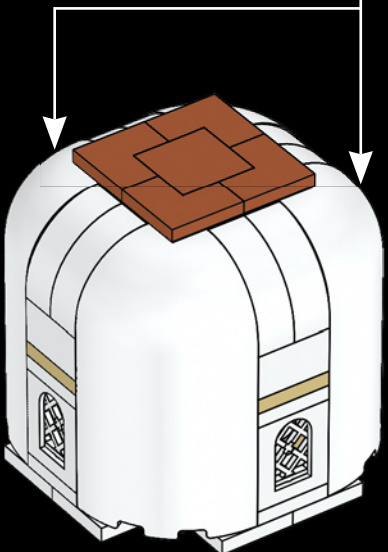
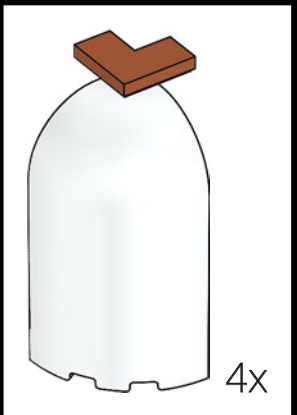

165

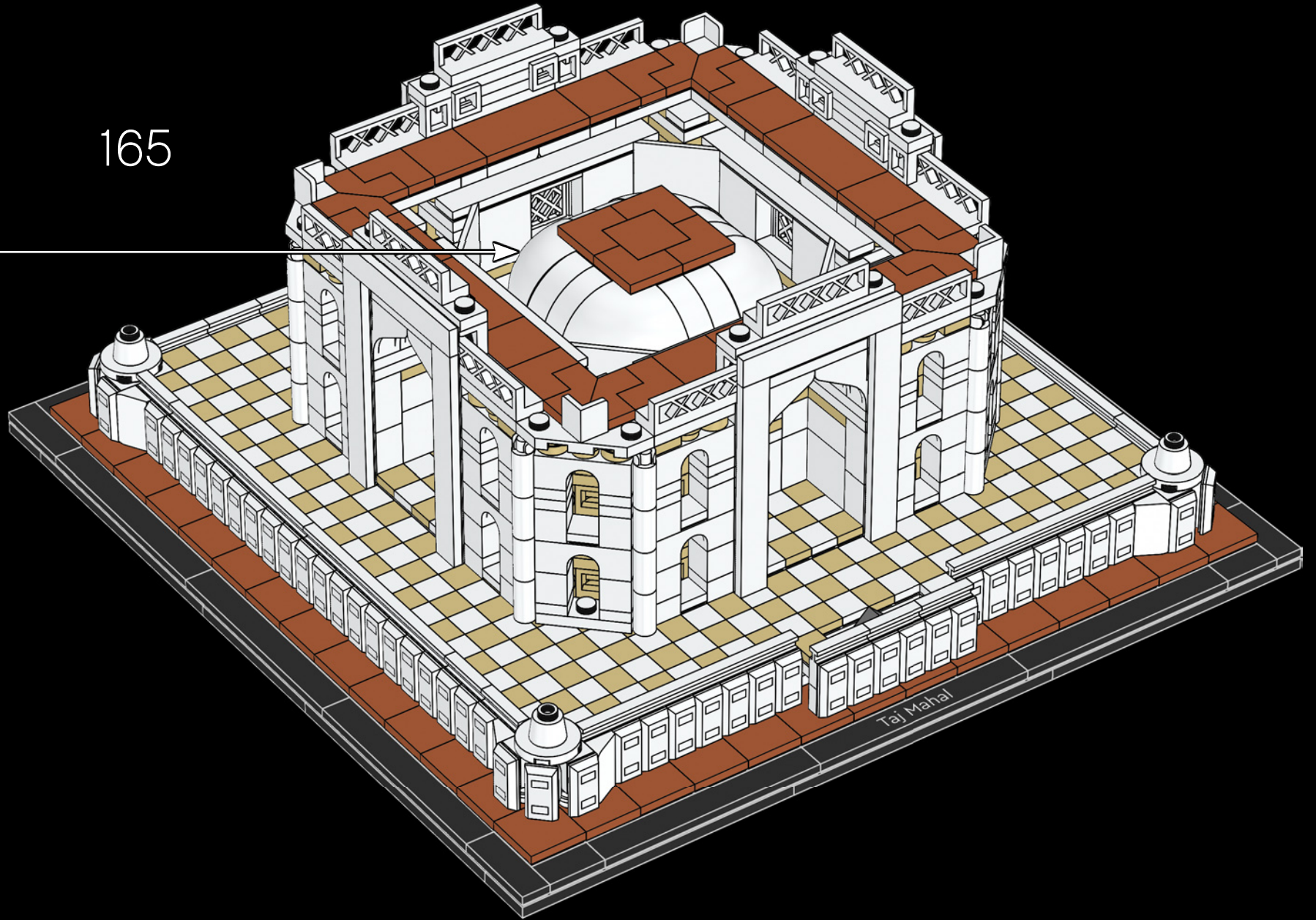

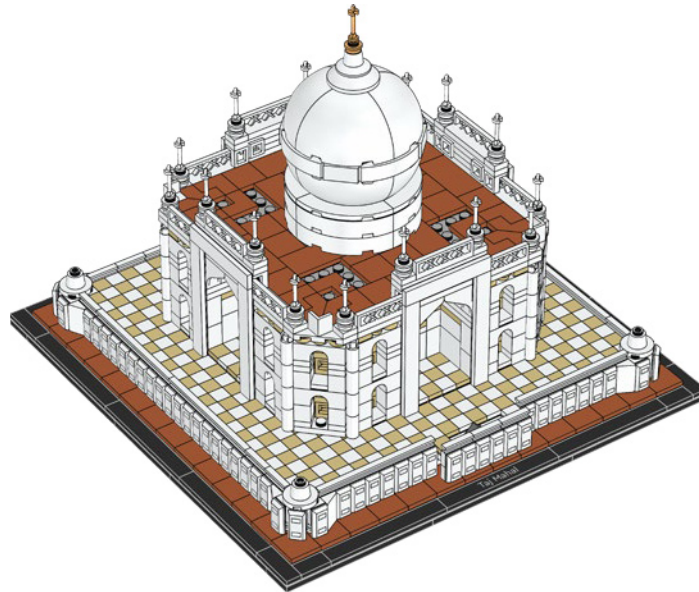
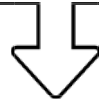

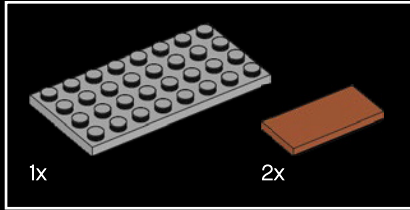
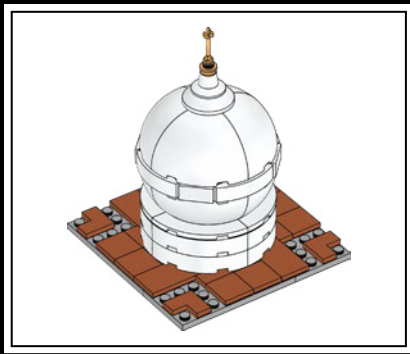

166

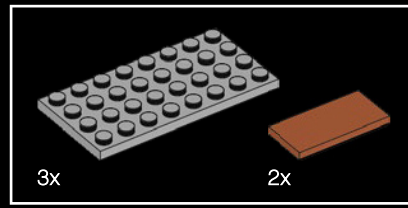
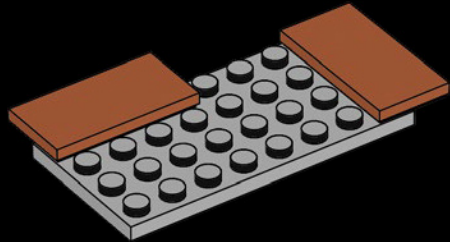

167

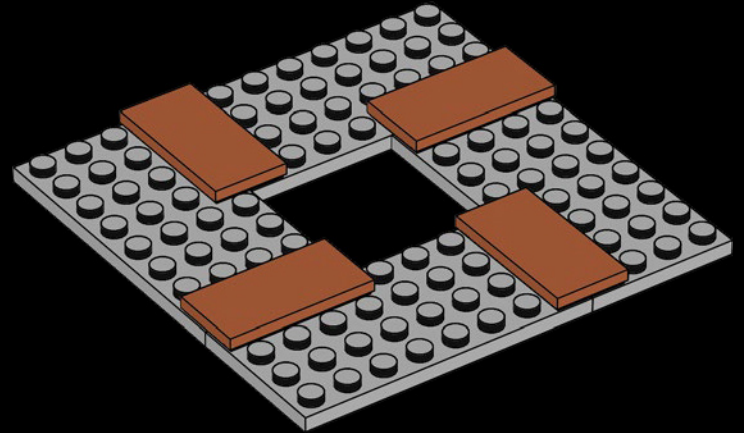

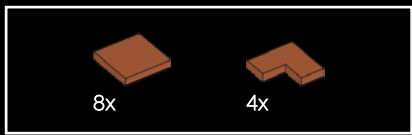

168

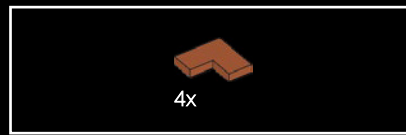
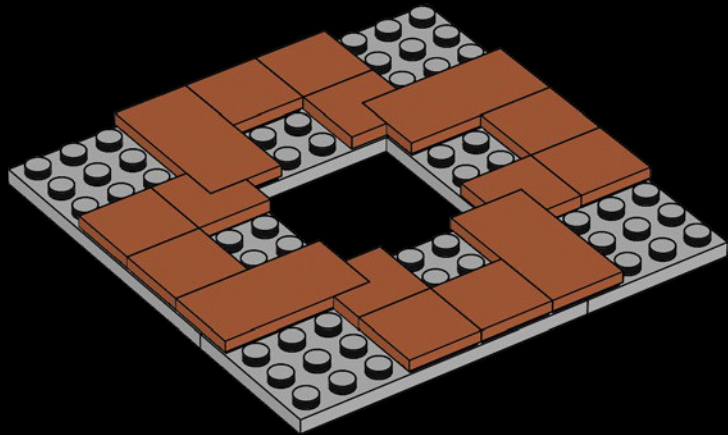

169

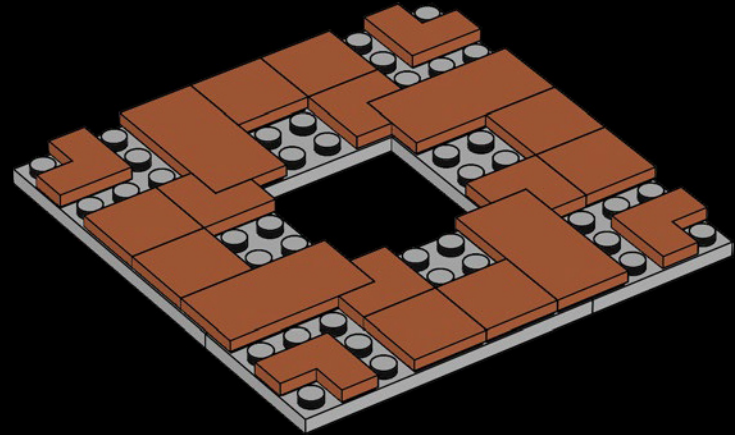

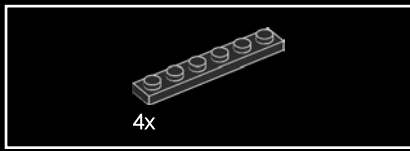

170

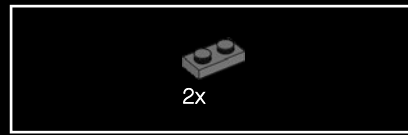
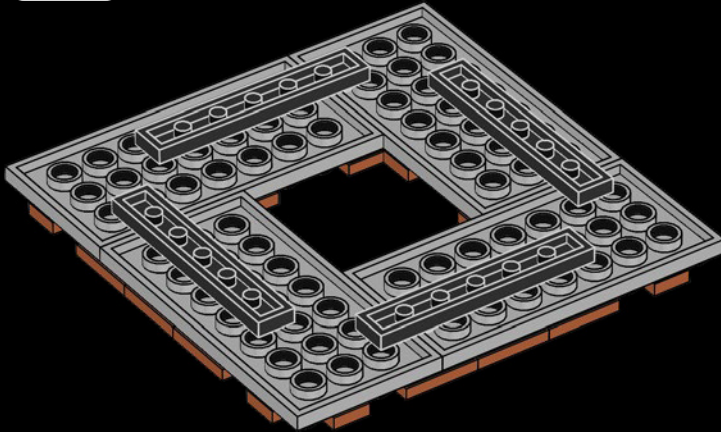

171

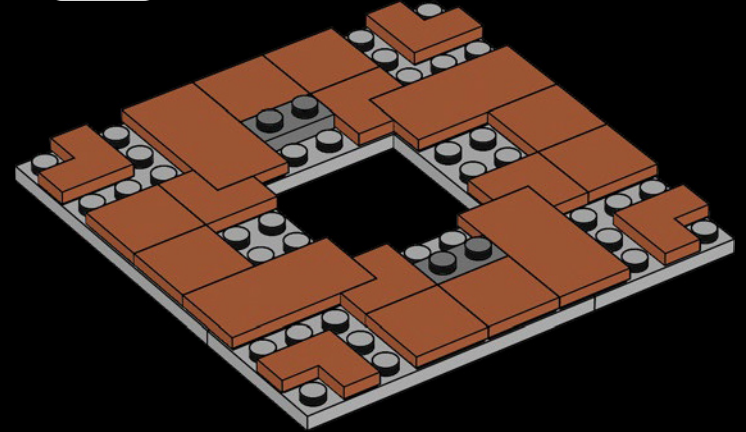

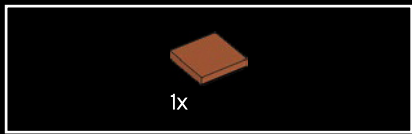

172

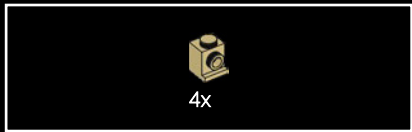
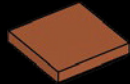

173

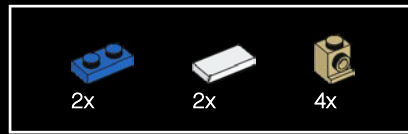

174

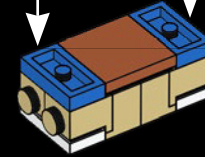
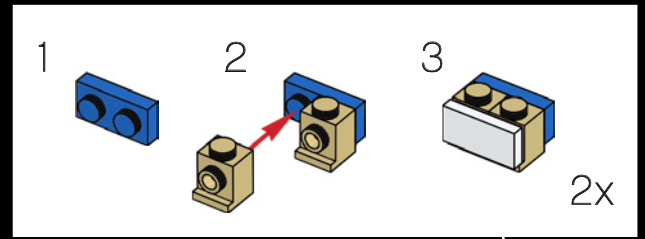

175

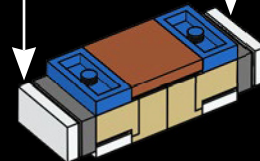
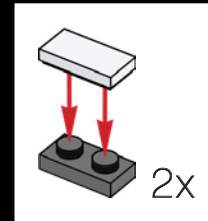

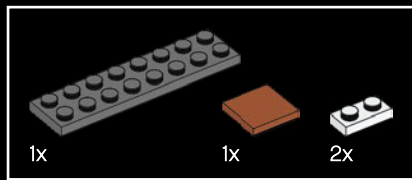

176

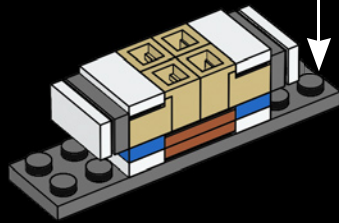
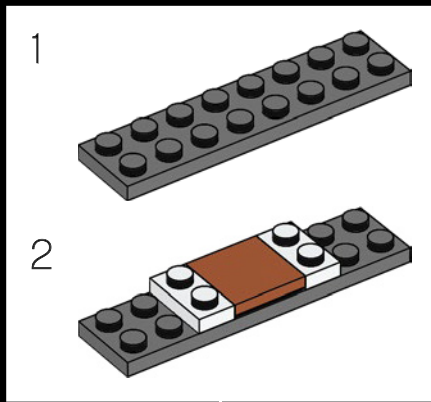

177

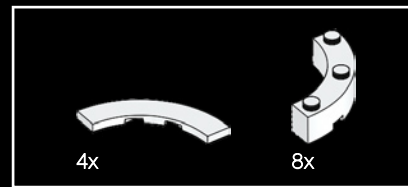
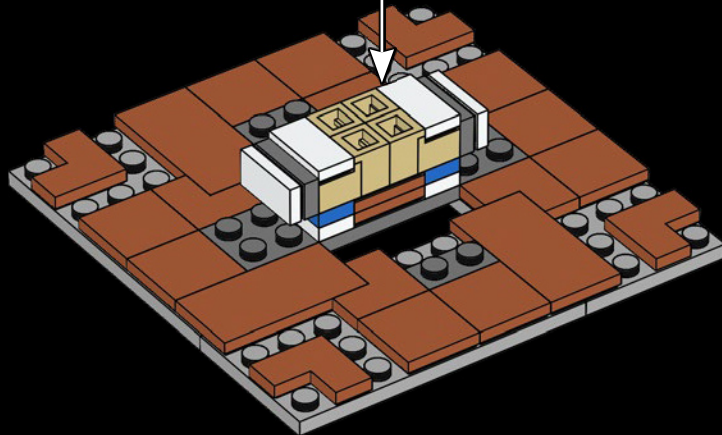

178

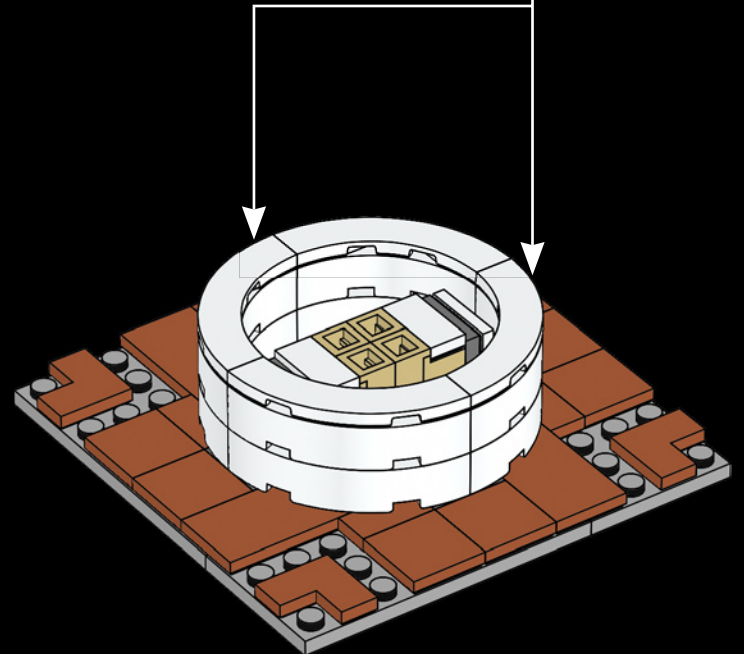
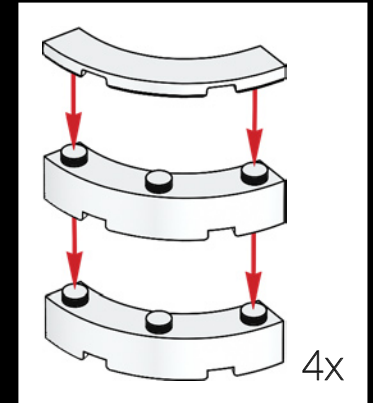

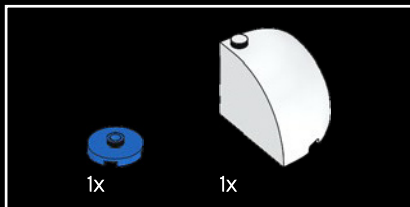

179

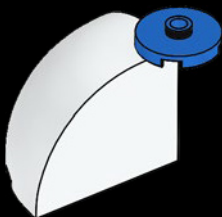

180

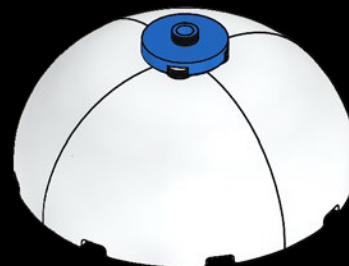

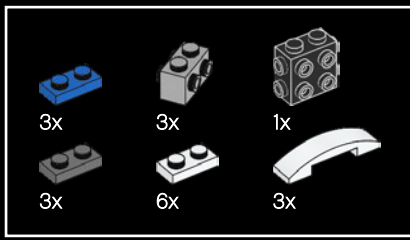

181

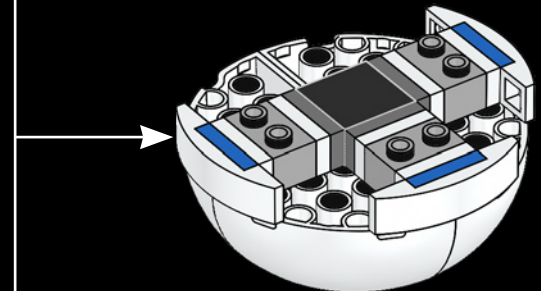
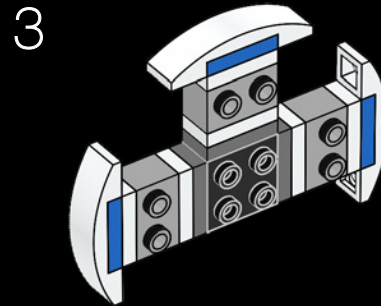
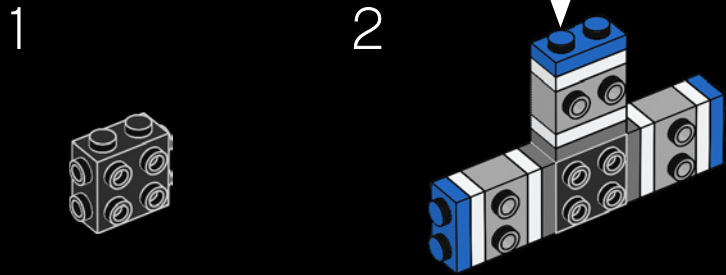
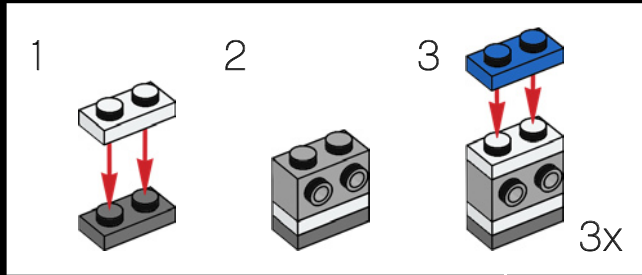

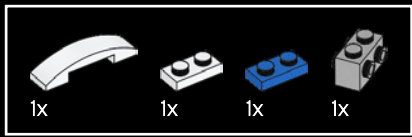

182

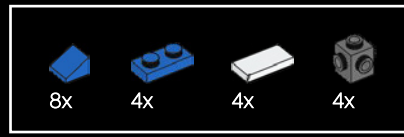
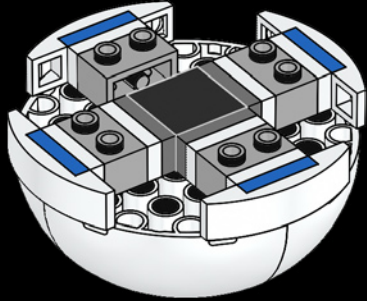
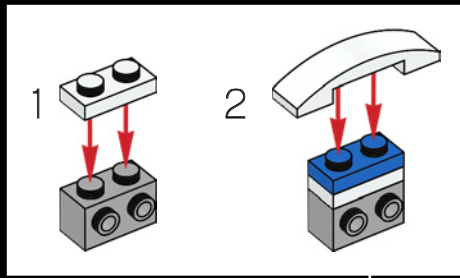

183

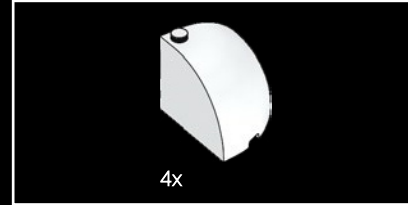
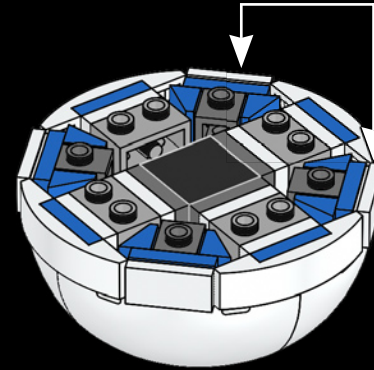
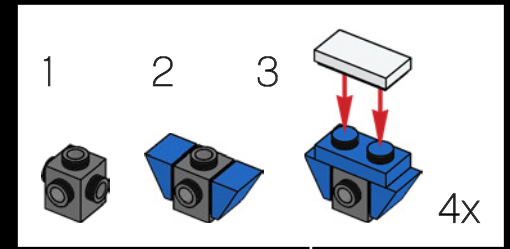

184

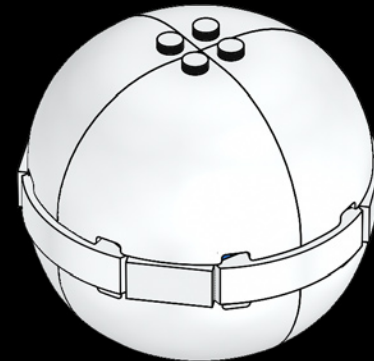

185

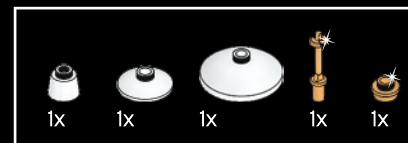
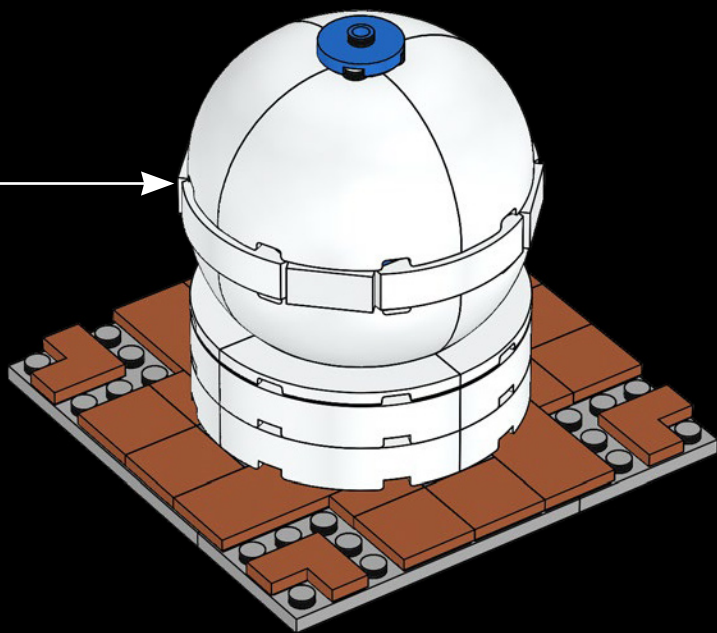

186

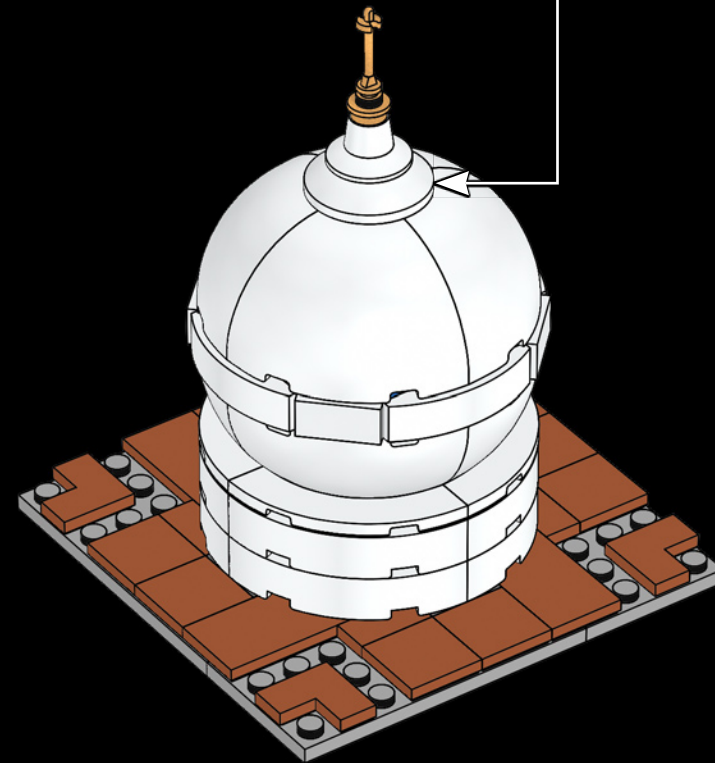
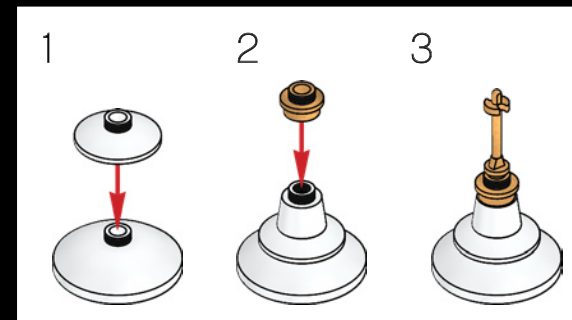

187

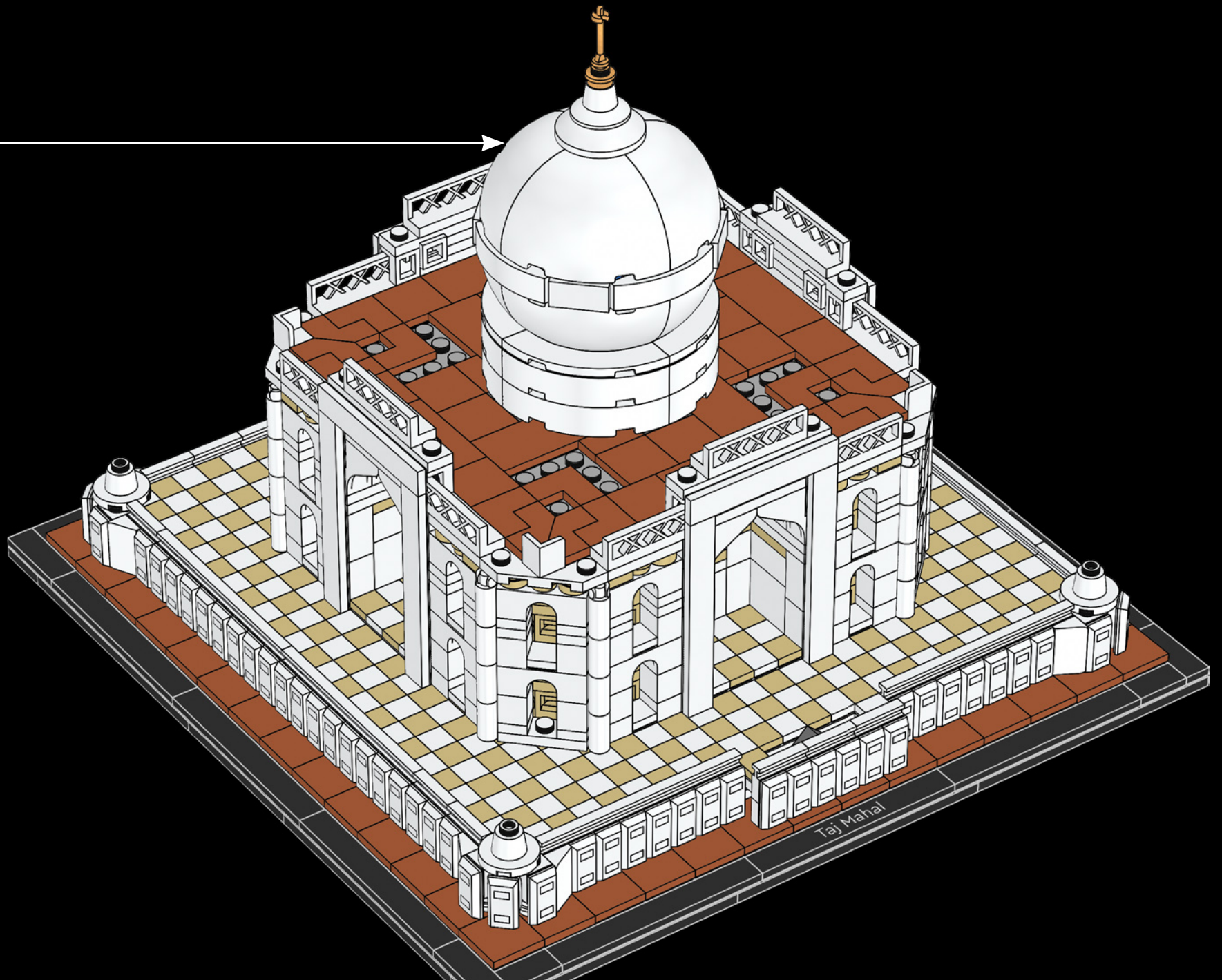

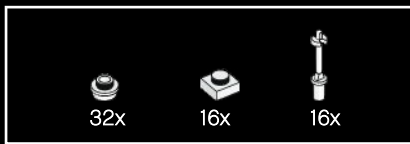

188

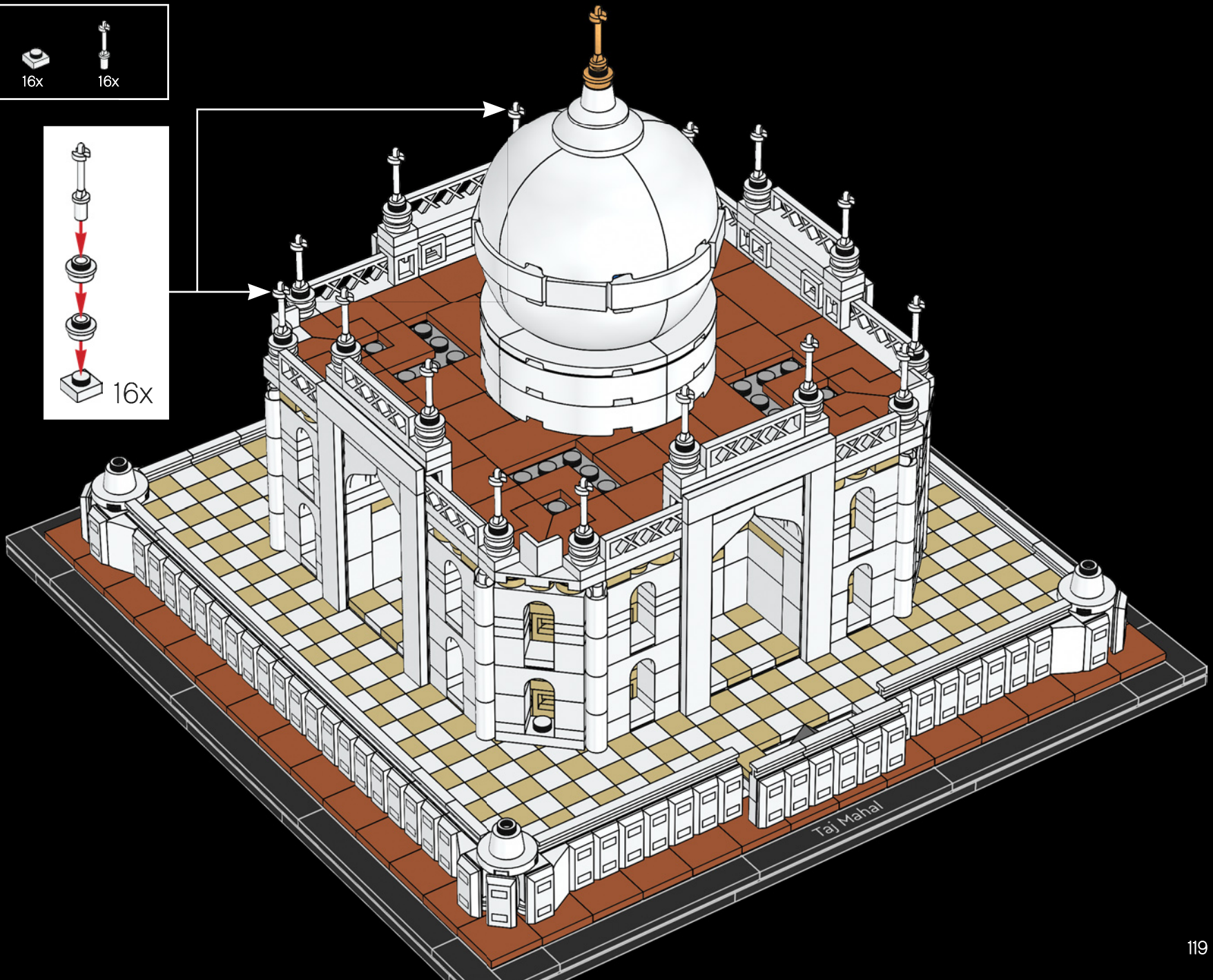
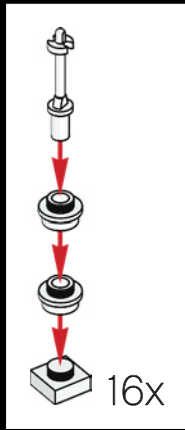

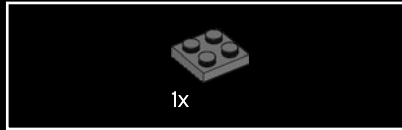
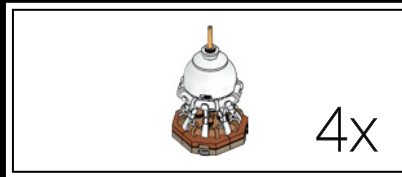
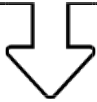

189

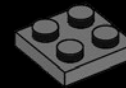



190

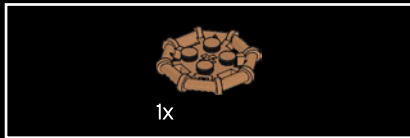
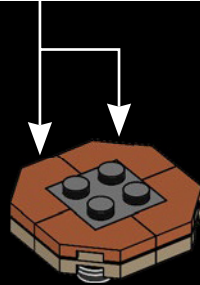
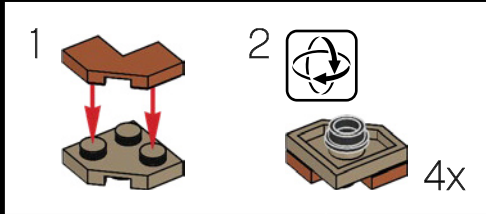

191

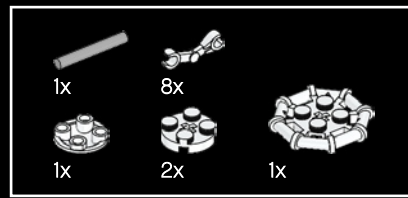

192

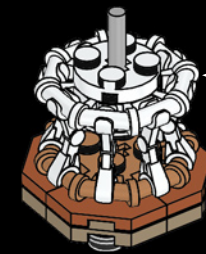
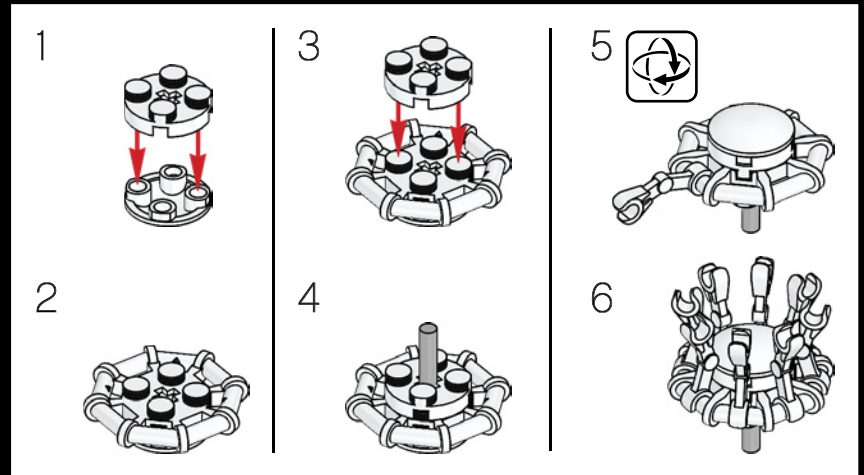



193



194



195

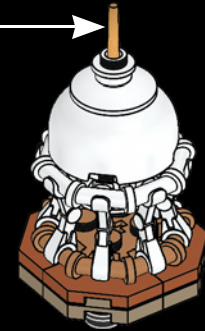

4x

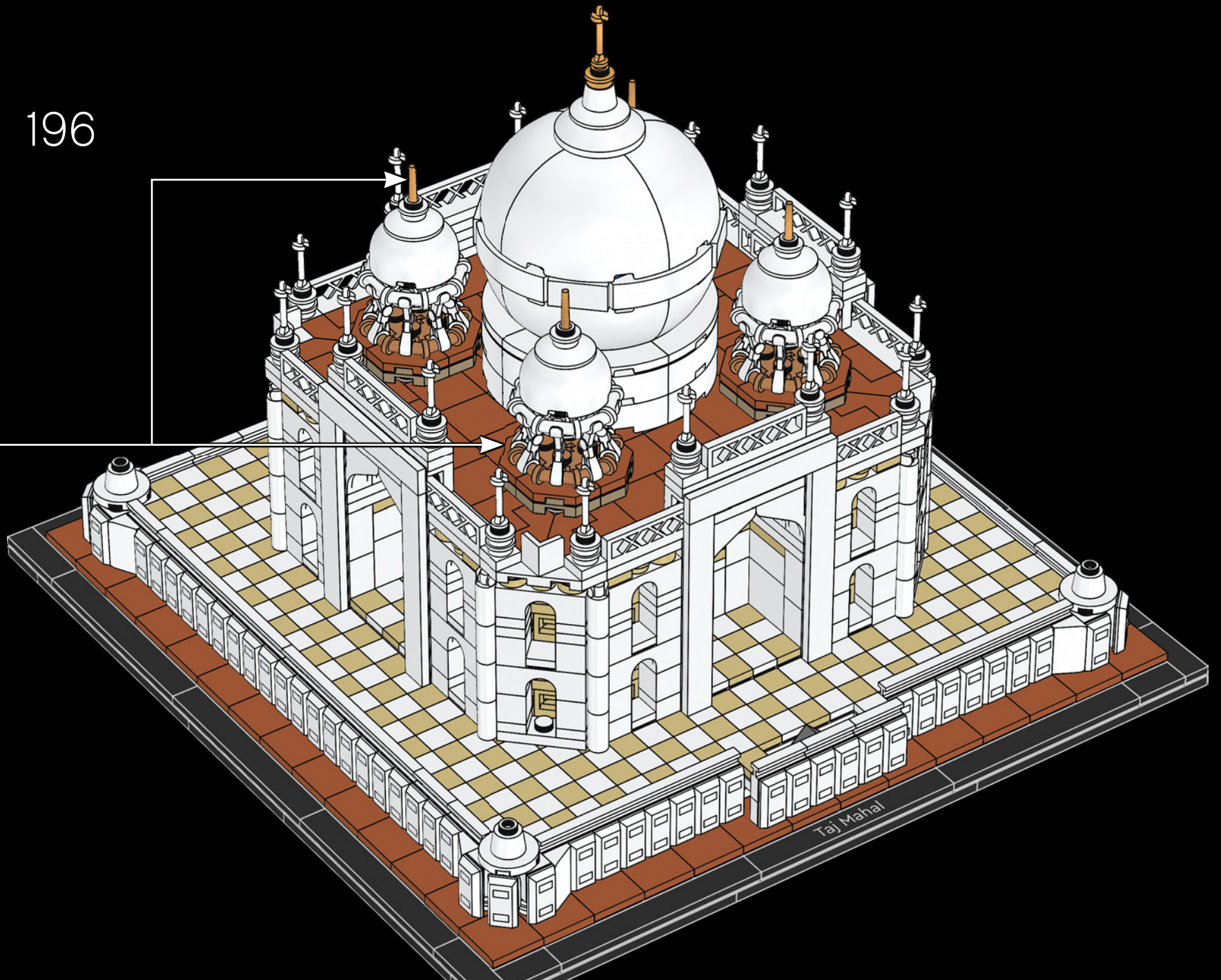

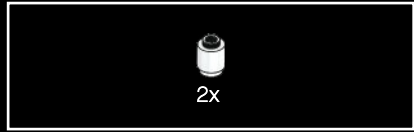
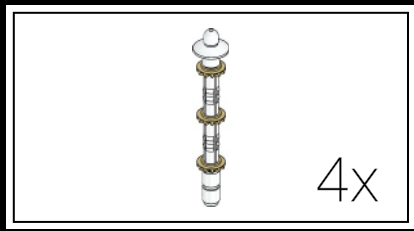

197



198

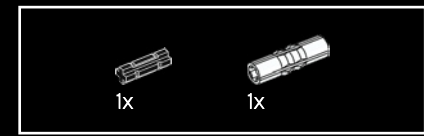

199



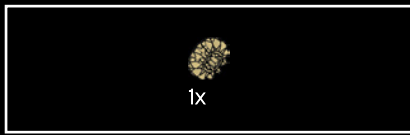

200

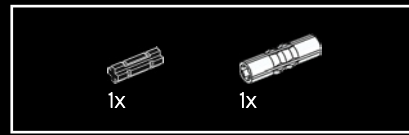

201



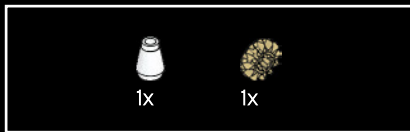

202



203

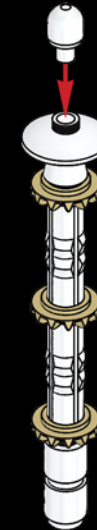

4x

As a safety measure, the four minarets lean slightly outward rather than stand straight. Thus, if any of them fell, they would fall away from the tomb.

Par mesure de sécurité, les quatre minarets sont légèrement inclinés vers l'extérieur plutôt que d'être parfaitement droits. Ainsi, en cas d'écroulement, ils tomberaient dans la direction opposée au tombeau.

Como medida de seguridad, los cuatro minaretes están ligeramente inclinados hacia afuera en lugar de permanecer rectos. De este modo, si alguno se derrumbara, no lo haría sobre las tumbas.



204

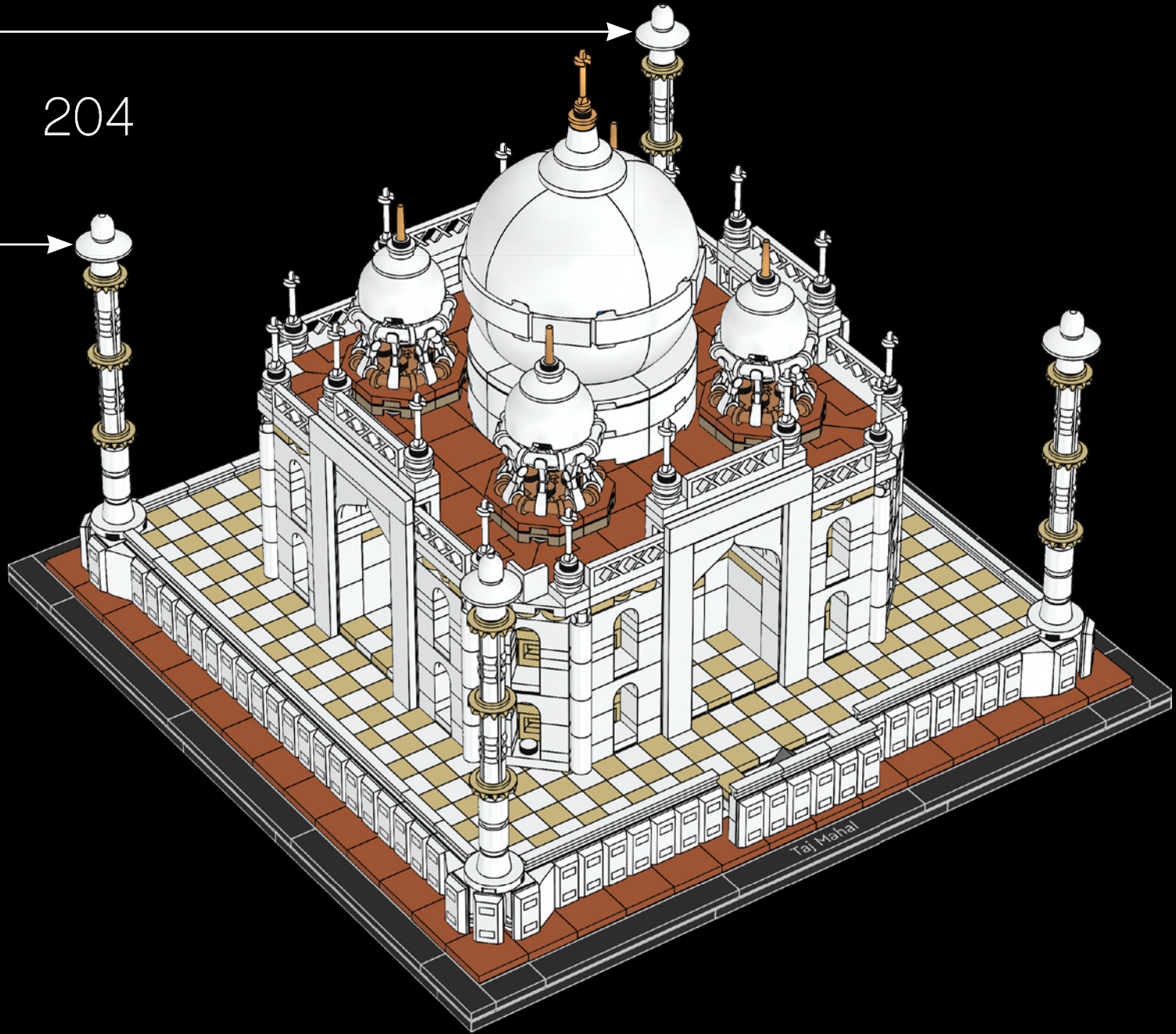

Celebrate the world of architecture and collect all the models
Célébrez le monde de l'architecture et collectionnez tous les modèles
Celebra el mundo de la arquitectura y colecciona todos los modelos

21045
Trafalgar Square



21042
Statue of Liberty
La statue de la Liberté
Estatua de la Libertad



21046
Empire State Building
L'Empire State Building



21054
The White House
La Maison-Blanche
La Casa Blanca



21028
New York City
New York
Nueva York



21043
San Francisco

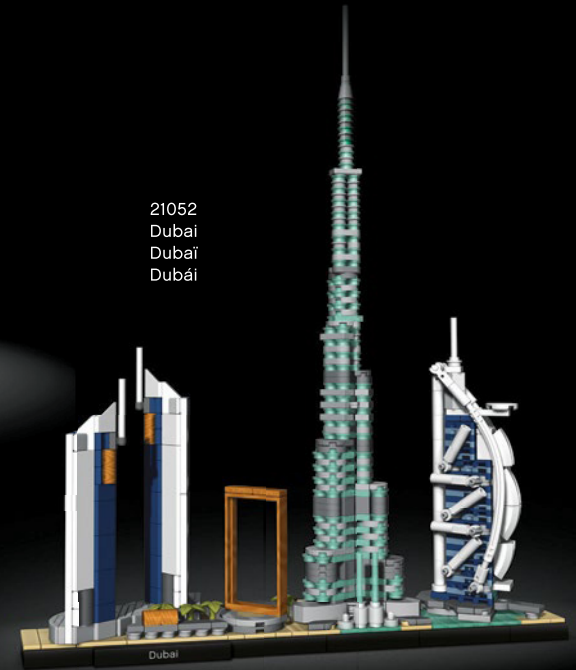

21052
Dubai
Dubāī
Dubái



21044
Paris

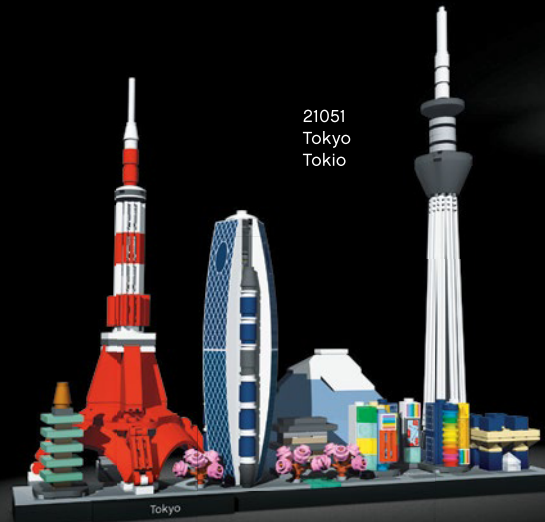

21051
Tokyo
Tokio



21034
London
Londres

The Transamerica Pyramid Building is a registered service mark of Transamerica Corporation and is being used with permission.

© Pyramide du Louvre, architecte I. M. Pei, musée du Louvre.

© TOKYO-SKYTREE

東京スカイツリー®/东京晴空塔®/TOKYO SKYTREE

© Jumeirah International LLC







FEEDBACK AND WIN



FEEDBACK AND WIN

Your feedback will help shape the future development of this product series.

Please visit:

FEEDBACK UND GEWINNEN

Dein Feedback trägt zur Weiterentwicklung dieser Produktreihe bei.

Geh auf:

COMMENTEZ ET GAGNEZ

Vos commentaires nous aideront à concevoir les futurs produits de cette gamme.

Rendez-vous sur :

COMENTA Y GANA

Tu opinión nos ayudará a dar forma al desarrollo de esta serie de productos en el futuro.

Visita:

反馈有奖

您的反馈将有助于我们在今后改进本系列产品。

请访问：

[LEGO.com/productfeedback](https://www.lego.com/productfeedback)

By completing, you will automatically enter a drawing to win a LEGO® set.

Terms & Conditions apply.

Durch Ausfüllen nimmst du automatisch an der Verlosung eines LEGO® Preises teil.

Es gelten die Teilnahmebedingungen.

En envoyant vos commentaires, vous serez automatiquement inscrit(e) à un tirage au sort qui vous permettra de remporter un prix LEGO®.

Offre soumise à conditions.

Al contestar, participarás automáticamente en el sorteo y podrás ganar un set LEGO®.

Sujeto a Términos y Condiciones.

完成我们的反馈调查，即可自动进入抽奖环节，赢取乐高®套装。

适用《条款和条件》。

LEGO and the LEGO logo are trademarks of the/son des marques de commerce du /son marcas registradas de LEGO Group. ©2021 The LEGO Group.

Adam Reed Tucker is the co-developer of the LEGO Architecture product line.
Adam Reed Tucker est le codéveloppeur de la gamme de produits LEGO Architecture.
Adam Reed Tucker es el codesarrollador de la línea de productos LEGO Architecture.

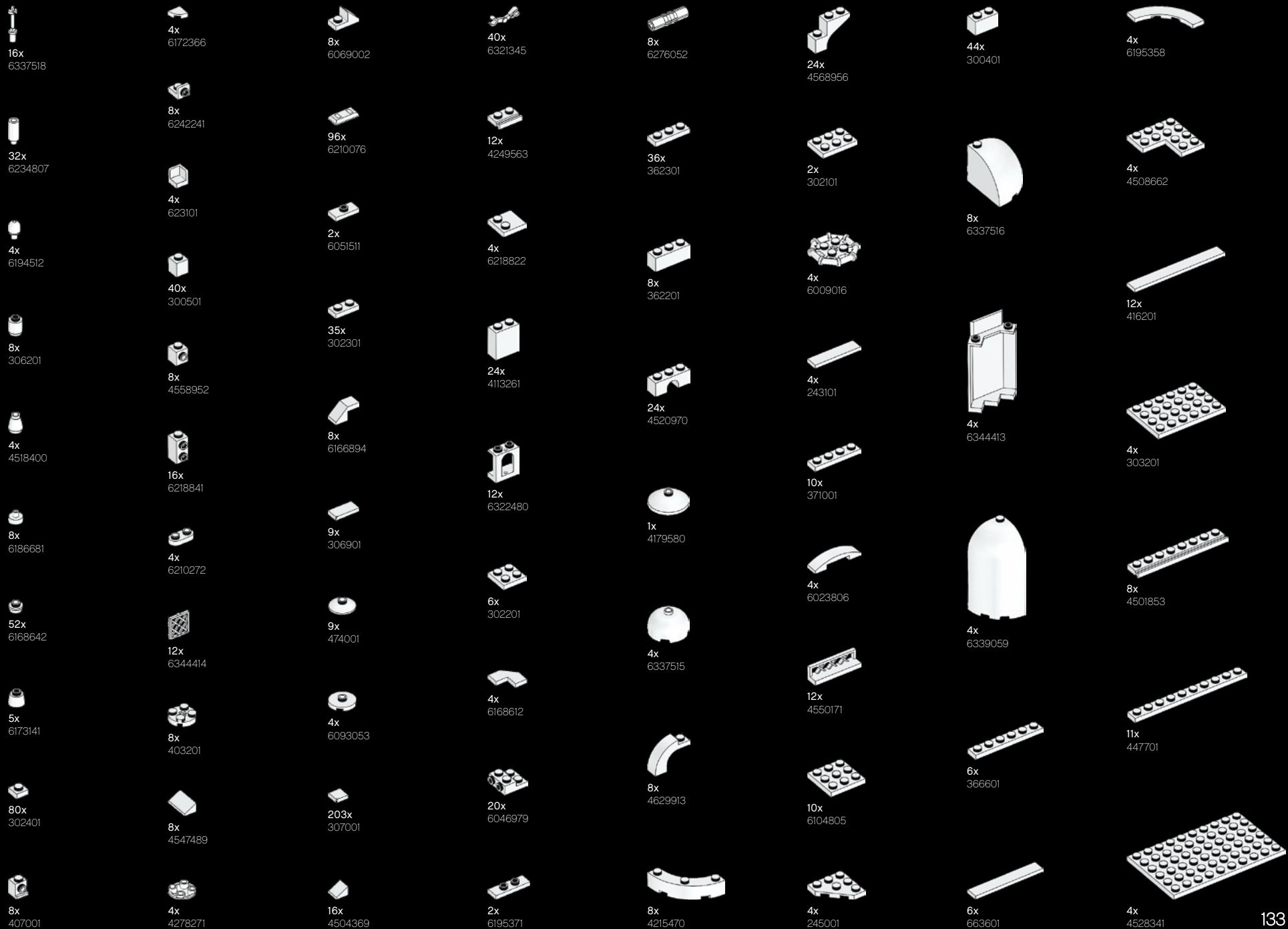

20x
6284573

16x
4109995

4x
4208072

8x
6186012

16x
6228921

44x
4161734

20x
4113917

4x
4124067

2x
4614158

8x
4550168

36x
4159553

4x
6314477

4x
4181134

61x
6186423

8x
6210581

60x
4118793

4x
6226565

4x
4113993

24x
6253425

4x
4211385

8x
6145570

4x
4124455

2x
4114324

28x
6341393

4x
6079461

191x
4125253

8x
4114077

4x
4125217

8x
6058089

2x
4211438

12x
4565452

12x
4121921

3x
6156462

4x
4640844

1x
6015349

8x
6212758

2x
6115031

4x
6093527

4x
4657459

24x
4211407

8x
6092587
134

1x
6292254

1x
6190252

2x
6342086

4x
6147169

4x
6177189

2x
4504378

4x
4210700

1x
4226221

7x
4211063

4x
4211094

1x
4210997

2x
300328

2x
4125281

4x
4107758

4x
4106356

8x
303428

2x
4153825

2x
6212079

4x
4153827

1x
6240515

8x
4504380

1x
6194417

10x
302323

33x
302123

1x
371023

4x
4243815

1x
4199519

16x
614126

8x
4109810

4x
306926

1x
6308883

4x
242026

4x
4558170

4x
300126

6x
366626

2x
379526

11x
416226

1x
6338083

4x
303226

10x
383226

Customer Service
Kundenservice
Service Consommateurs
Servicio Al Consumidor
LEGO.com/service or dial

 : 00800 5346 5555
: 1-800-422-5346



